

April 2024

Hydrogen-Powered Truck Operations in Kentucky Feasibility Study



HYDROGEN-POWERED TRUCK OPERATIONS IN KENTUCKY

Feasibility Study

April 2, 2024



Executive Summary

This feasibility study examined the potential for hydrogen powered truck operations in Kentucky. It identified opportunities, constraints, and possible funding sources. It considered two potential hydrogen truck refueling scenarios and outlines a proposed action plan for moving forward.

Scenarios and Investment Levels Examined

Scenario 1: Long-Distance Point-to-Point Freight Operations - The first scenario examined long-distance freight operations serving major manufacturing facilities. This arrangement would connect manufacturing facilities (and possibly suppliers) along a major manufacturing corridor.

Scenario 2: Centralized Hub and Spoke Freight Operations – The second scenario explored a regional hub-and-spoke operation. In this situation, all vehicles would depart from, and return to, the same facility each day.

For each scenario, three conceptual levels of station investment were considered:

1. **Pilot Scale** – Small temporary station
2. **Liquid Delivery** - Permanent station receiving liquid delivery
3. **On-site Generation** - Permanent station with on-site hydrogen production

Based on the analysis, a liquid delivery investment is likely the best approach. An initial installation could effectively serve up to 20 trucks per day for the long-distance scenario and up to 50 trucks per day for the hub and spoke operation. The capital costs for initial investment levels across all three concepts are summarized below. Operations, fuel, and vehicle costs are outlined in the report.

Concepts	Scenario 1 Long-Distance Point-to-Point Three Stations	Scenario 2 Centralized Hub and Spoke One Station
Pilot Scale	\$8 - \$20 million	\$3 - \$7 million
Liquid Delivery	\$20 – \$40 million	\$8 – \$15 million
On-site Generation	~\$100 million	~\$50 million

Federal Programs

There are numerous federal programs across several different departments that could help advance the program in Kentucky. Several to be aware of include:

- Hydrogen Alternative Fuel Corridors (USDOT, see figure below)
- Charging and Fueling Infrastructure Program (USDOT)
- National Zero-Emission (ZEM) Freight Corridor Strategy (Joint Office)
- Regional Clean Hydrogen Hub Program (USDOE)
- H2Hubs Demand-side Initiative (USDOE)
- Federal Incentives: IRC 48C, 45V, 45W, and 45Q; IRS tax credits; USDOE loan programs

One of the most promising capital funding programs is the **USDOT Charging and Fueling Infrastructure (CFI) Program**. This program was recently used by Metropolitan Planning Organizations in the Texas Triangle region to secure \$70 million in funding for truck hydrogen refueling stations.

Action Plan

The action plan outlined below offers actionable steps that could be taken to advance hydrogen powered truck fueling in the state. The agencies listed as responsible for different actions could change over time, but this initial list proposes entities that could implement these actions.

Timeline	Recommended Action	Responsible Agencies
Continuous	Build awareness about hydrogen in the transportation sector	EEC, KYTC, MPOs, Workgroup
	Build hydrogen and transportation industry partnerships	EEC, KYTC, MPOs, Workgroup
	Identify funding for hydrogen research, development, and infrastructure	EEC, Universities, MPOs, Workgroup
Short (1-2 years)	Coordinate with public agencies to develop a request for partners establishing hydrogen fueling stations in the State	EEC, KYTC, MPOs
	Research emerging examples of truck hydrogen refueling	EEC, Universities, Workgroup
Medium (2-5 years)	Apply for CFI Grant for hydrogen fueling stations	TBD
	Formalize off-take agreements with Arch2 and MachH2	TBD
	Incubate green technology and hydrogen production in Kentucky	EEC, Universities
Long (5-10 years)	Develop hydrogen infrastructure standards	EEC, KYTC
	Build-out hydrogen AFCs	EEC, KYTC, MPOs
	Identify and implement industry partnerships for future high-volume hydrogen production	TBD

Table of Contents

Executive Summary	i
Introduction	1
Trucks and Hydrogen Power	2
Fuel Cells	2
Hydrogen Fuel Cell Electric Vehicles	2
Hydrogen Fuel Distribution	2
Hydrogen Fuel Production	3
Transportation Carbon Emissions.....	3
Carbon Emissions from Hydrogen Production	4
Cost of Hydrogen Production.....	4
Challenges Based on the State of the Technology	5
Industry Overview	6
Vehicle Manufacturing	6
Hydrogen Production, Distribution, and Refueling	7
Consumers Considering Hydrogen.....	8
Hydrogen Research in Kentucky	10
Industry Overview Conclusions.....	11
Federal and State Programs and Initiatives.....	12
U.S. Department of Transportation (USDOT)	12
U.S. Department of Energy (US DOE).....	17
Other Federal Programs and Incentives	19
Kentucky Incentives and Assistance.....	21
Market Demand	22
General Freight Flows in Kentucky.....	22
Kentucky in the National Context.....	22
Partnership Opportunities in Kentucky.....	24
Concepts and Site Locations.....	27
Scenario 1: Long-Distance Point-to-Point Freight Operations.....	27
Scenario 2: Centralized Hub and Spoke Freight Operations.....	28
Station Concepts	30
Feasibility Assessment Findings	38
Opportunities	38
Constraints	38
Scenarios and Concepts	38
CFI Grant Opportunity	39
Action Plan	40

Table of Figures

Figure 1: Hydrogen Fuel Cell	2
Figure 2: Hydrogen Fuel Cell Stack.....	2
Figure 3: Hydrogen Fuel Cell Electric Truck	2
Figure 4: Hydrogen Delivery Models	3
Figure 5: 2019 US Greenhouse Gas Emissions	3
Figure 6: Estimated and Projected Clean Hydrogen Costs.....	5
Figure 7: US DOE’s Regional Clean Hydrogen Hubs	7
Figure 8: Proposed Hydrogen Fueling Station and EV Charging Station at U of L.....	10
Figure 9: National Federally Designated Hydrogen AFCs	12
Figure 10: Kentucky’s Federally Designated Hydrogen AFCs	13
Figure 11: CFI Hydrogen Refueling Stations Awarded in 2024.....	14
Figure 12: National ZEM Freight Corridor Strategy Phase 1.....	15
Figure 13: National ZEM Freight Corridor Strategy Phase 2.....	15
Figure 14: National ZEM Freight Corridor Strategy Phase 3.....	16
Figure 15: National ZEM Freight Corridor Strategy Phase 4.....	16
Figure 16: CFI Hydrogen Refueling Stations Awarded in 2024.....	17
Figure 17: Regional H2Hubs with Alternative Fuel Corridors for Hydrogen	18
Figure 18: Designated Energy Communities (IRC 48C)	19
Figure 19: 2017 Truck Flows in Kentucky and Surrounding States.....	22
Figure 20: Kentucky’s Hydrogen Landscape Within the National H2Hub Context	23
Figure 21: Hydrogen Landscape in Kentucky	25
Figure 22: Route between Georgetown and Huntsville.....	28
Figure 23: Medium-Duty FCEV Truck	29
Figure 24: Hub-and-Spoke Scenario (100-mile range)	29
Figure 25: Flow Diagram for Equipment Required for Gaseous Delivery Concept.....	33
Figure 26: Site Layout for Gaseous Delivery Concept.....	33
Figure 27: Flow Diagram for Equipment Required for Liquid Delivery Concept	35
Figure 28: Site Layout for Liquid Delivery Concept.....	35
Figure 29: Flow Diagram for Equipment Required for On-Site Generation Concept	37
Figure 30: Site Layout for On-Site Generation Concept	37
Figure 31: Texas Hydrogen Truck Fueling Initiative	39

Table of Tables

Table 1: Hydrogen Production Processes	3
Table 2: Spectrum of Production Techniques for Producing Hydrogen	4
Table 3: Long-Distance Point-to-Point Freight Operations	30
Table 4: Regional Hub and Spoke Operations	30
Table 5: Comparison of Hydrogen Fueling Concepts (Initial Assumptions)	31
Table 6: Order of Magnitude Capital Cost Estimates.....	36
Table 7: Action Plan.....	40

Introduction

Freight and freight related industries are central to Kentucky's economy. In 2022, according to the Bureau of Labor Statistics, 12 percent of the jobs in Kentucky were in the transportation sector, the highest percentage of any state. Kentucky is also a major manufacturing state, with 9.8 percent of the jobs in the state related to production (5th highest in the county). The resulting truck flows are major contributors to the state's emissions as documented in Kentucky's Carbon Reduction Strategy that was approved by the Federal Highway Administration (FHWA) in February 2024. Therefore, Kentucky's Energy and Environment Cabinet (EEC) prepared this feasibility study to assess the potential for implementing hydrogen fueling stations in the state to support the transition of trucks to hydrogen fuel. Hydrogen fuel offers the substantial benefit of eliminating mobile emissions, instead emissions are related primarily to the production and transport of the fuel. In addition, given Kentucky's position in the manufacturing and transport fields, it is important for the state to be a leader in new freight transportation technologies. Companies such as Toyota, Ford, and General Motors are all manufacturing, or planning to manufacture, fuel cells and/or electric vehicle batteries in the state.

The initial focus of the study was on the potential for hydrogen refueling to support long-distance tractor-trailer freight operations. The state currently has seven federally designated Hydrogen Alternative Fuel Corridors (AFC's): I-64, I-75, I-65, I-24, I-69, I-71, and I-165. It was proposed that stations could be installed on one or more of these corridors to support companies piloting the shift to hydrogen power for long-distance point to point freight shipments. However, as the study progressed, it became clear that an alternative approach would be to focus on hub and spoke or "milk run" operations that involve refueling medium-duty trucks that are making shorter runs and returning to the same location at the end of every run. Therefore, both alternatives were considered.

The framework of the document includes the following major sections:

- **Trucks and Hydrogen Power** – Overview of the technology
- **Industry Overview** – Current state of the industry
- **Federal and State Programs and Initiatives** – Grants, tax credits, and other programs
- **Future Market Demand** – Potential future demand for hydrogen in Kentucky
- **Fueling Scenarios and Concepts** – Long-distance or hub-and-spoke scenarios
- **Feasibility Assessment Findings** – Summary of findings and action steps

Trucks and Hydrogen Power

Fuel Cells

Hydrogen fuel cell trucks use hydrogen and oxygen to generate electricity (**Figure 1**). The chemical process within each fuel cell emits water and heat. Several fuel cells can be combined into a fuel cell stack to generate enough energy to power a medium- or heavy-duty truck (**Figure 2**).

Hydrogen Fuel Cell Electric Vehicles

The electricity generated by the fuel cell stack runs an electric traction motor that propels the truck (**Figure 3**). The electricity also charges a battery which provides supplemental power to the motor during acceleration and stores the energy generated from regenerative braking. The equipment needed for a large hydrogen powered fuel cell electric vehicle (FCEV) weighs less than the equipment for a battery only electric vehicle, allowing the vehicle to carry more cargo weight. The gaseous hydrogen is pumped into vehicle tanks from a fueling station. Modern FCEV trucks can refuel in 15 minutes or less. While this technology is advancing, there are still very few hydrogen powered trucks available and their cost is significantly higher than their diesel counterparts.

Hydrogen Fuel Distribution

In transportation applications, hydrogen is typically generated off-site by bulk hydrogen producers and transported by truck to a fueling station in a manner similar to diesel fuel (**Figure 4**). Hydrogen can be procured and delivered in either a gaseous state or a liquid state. Both delivery methods are commonly available from many hydrogen producers. The choice between gaseous or liquid delivery is largely determined by the total volume of hydrogen that a site requires. For small scale hydrogen projects, gaseous hydrogen delivery allows for a simpler integration and less equipment installed on site. Liquid hydrogen on the other hand, is much denser than gaseous hydrogen and allows for large quantities of the fuel to be transported to site. To enable liquid deliveries, complex equipment is required to maintain the hydrogen at cryogenic temperature and to return it to a gaseous state for use in vehicles. It is also possible to generate hydrogen on-site.

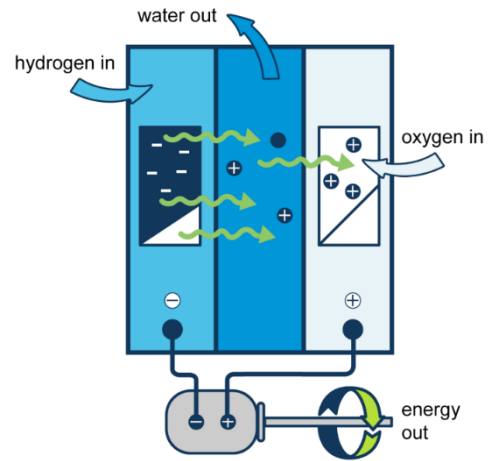

Source: US Department of Energy

Figure 1: Hydrogen Fuel Cell

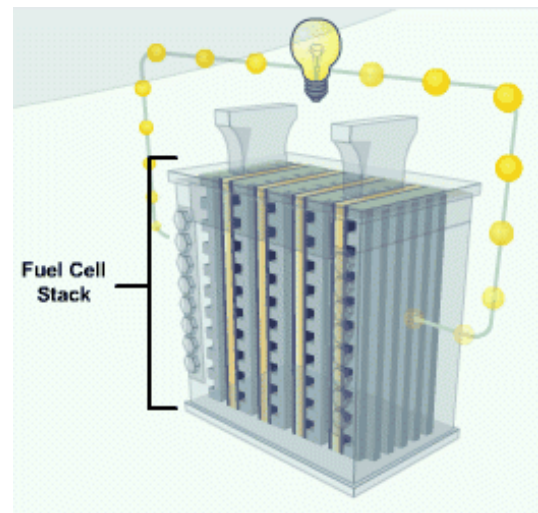

Source: US Department of Energy

Figure 2: Hydrogen Fuel Cell Stack

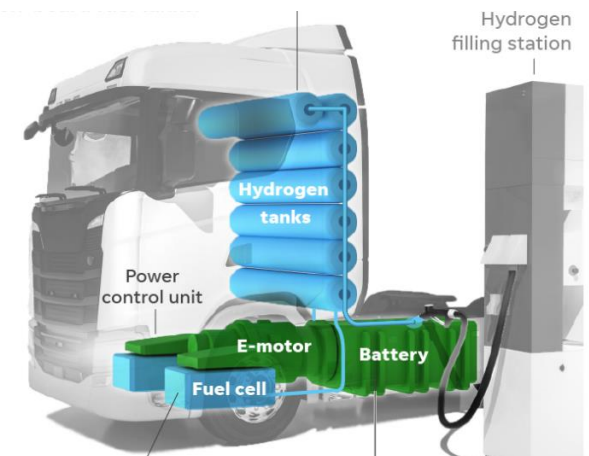

Source: USA Today

Figure 3: Hydrogen Fuel Cell Electric Truck

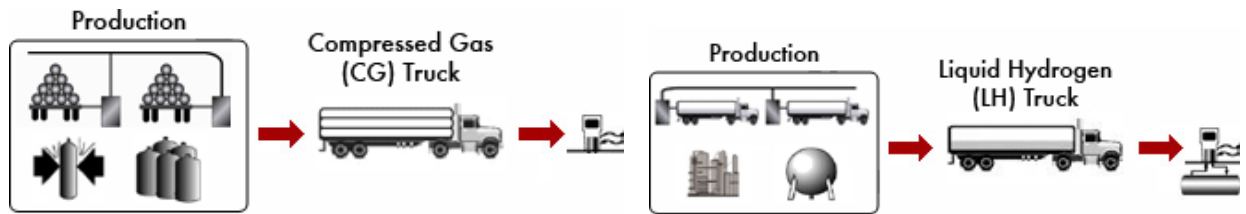

Source: US Department of Energy

Figure 4: Hydrogen Delivery Models

Hydrogen Fuel Production

Hydrogen production processes fall into three categories: fossil resources, biomass/waste, and water splitting (**Table 1**). The majority of hydrogen is generated using fossil resources to serve industrial needs. This can result in considerable carbon emissions. However, there are many agencies and firms working to make low-carbon hydrogen production more cost-effective.

Table 1: Hydrogen Production Processes

Fossil Resources	Hydrogen from fossil resources is typically produced through an industrial gas reformation process which strips hydrogen atoms from the hydrocarbons in the fossil fuel. For solid fuels such as coal, additional gasification equipment is required. Carbon capture, utilization, and storage (CCUS) can reduce carbon emissions from this process. Currently, 95 percent of all hydrogen produced in the US is made using natural gas reformation (grey hydrogen).
<i>examples</i> Natural Gas with CCUS Coal Gasification with CCUS	
Biomass/Waste	Hydrogen can be created by reforming or fermenting waste biogas streams from landfills and wastewater treatment plants, or it can be created from biofuels. Hydrogen produced from these sources has the potential to have a lower carbon footprint than traditional fossil fuels.
<i>examples</i> Biomass Conversion Waste Streams to Energy	
H2O Splitting	The electrolysis process uses electricity to split the hydrogen atoms and oxygen atom in a water molecule to form hydrogen (H ₂) and oxygen (O ₂) gases. Electrolyzers can be powered by the electric grid or by onsite renewables (wind, solar, hydro, geothermal).
<i>examples</i> Renewable Electrolysis Nuclear Electrolysis	

Transportation Carbon Emissions

According to the U.S. Environmental Protection Agency (EPA), transportation emissions represent the largest share of all greenhouse gas (GHG) emissions with 33 percent of the total in 2019 (**Figure 5**). Medium- and heavy-duty vehicles make up 21 percent of that amount, while they are only a fraction of the traffic on the nation's highways. (In 2019, trucks made up about 30% of the on-road emissions but only 10% of the total vehicle miles traveled. [BTS]) Therefore, if emissions from medium- and heavy-duty vehicles can be reduced it could yield a meaningful reduction in emissions.

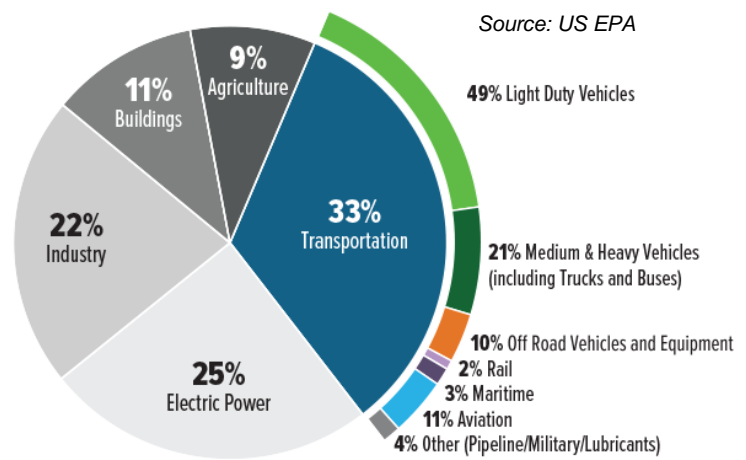









Figure 5: 2019 US Greenhouse Gas Emissions

Carbon Emissions from Hydrogen Production

The method used to produce hydrogen impacts its decarbonization potential. As shown in **Table 2**, different colors have been assigned to each process, with net carbon emissions generally increasing from green (lowest) to black (highest).

Table 2: Spectrum of Production Techniques for Producing Hydrogen

	Terminology	Technology	Feedstock	
	Green	Electrolysis	Wind Solar Hydro Geothermal Tidal	Production via electricity
	Pink		Nuclear	
	Yellow		Mixed-origin grid energy	
	Blue	Natural gas reforming + CCUS Gasification + CCUS	Natural gas w/ CCS coal w/CCS	Production via fossil fuels
	Turquoise	Pyrolysis (Solid Carbon byproduct)	Natural gas	
	Grey	Natural gas reforming		
	Brown	Gasification	Brown coal (Lignite)	
	Black		Black coal (Anthracite/Bituminous)	

Note: Biomass/waste typically is classified as blue or grey (similar to natural gas)

Table adapted from National Renewable Energy Laboratory (NREL) [“Hydrogen 101: Frequently Asked Questions About Hydrogen for Decarbonization”](#)

Cost of Hydrogen Production

The costs for producing hydrogen, using the processes highlighted in **Table 2**, differ significantly. To reduce carbon emissions, it is necessary to work toward producing and using electrolytic hydrogen. As illustrated in **Figure 6**, US DOE’s [National Clean Hydrogen Strategy and Roadmap](#) estimates that current low-volume production costs for electrolytic hydrogen range from \$5.00 to \$7.00 per kilogram (kg) and delivery and dispensing costs range from \$9.50 to \$11.00/kg, leading to a combined cost of \$14.50 to \$18.00/kg. By increasing production, economies of scale can be achieved, and it is expected that these costs could come down to a combined total cost of \$8.50 to \$12.50/kg. The goal is to ultimately bring the combined cost down to \$3/kg by 2030.

One kg of hydrogen has the same energy content as 1 gallon (3.2 kg) of gasoline. Therefore, at current costs, electrolytic hydrogen is considerably more expensive than diesel, but if the 2030 goal can be achieved it would be cost comparable.

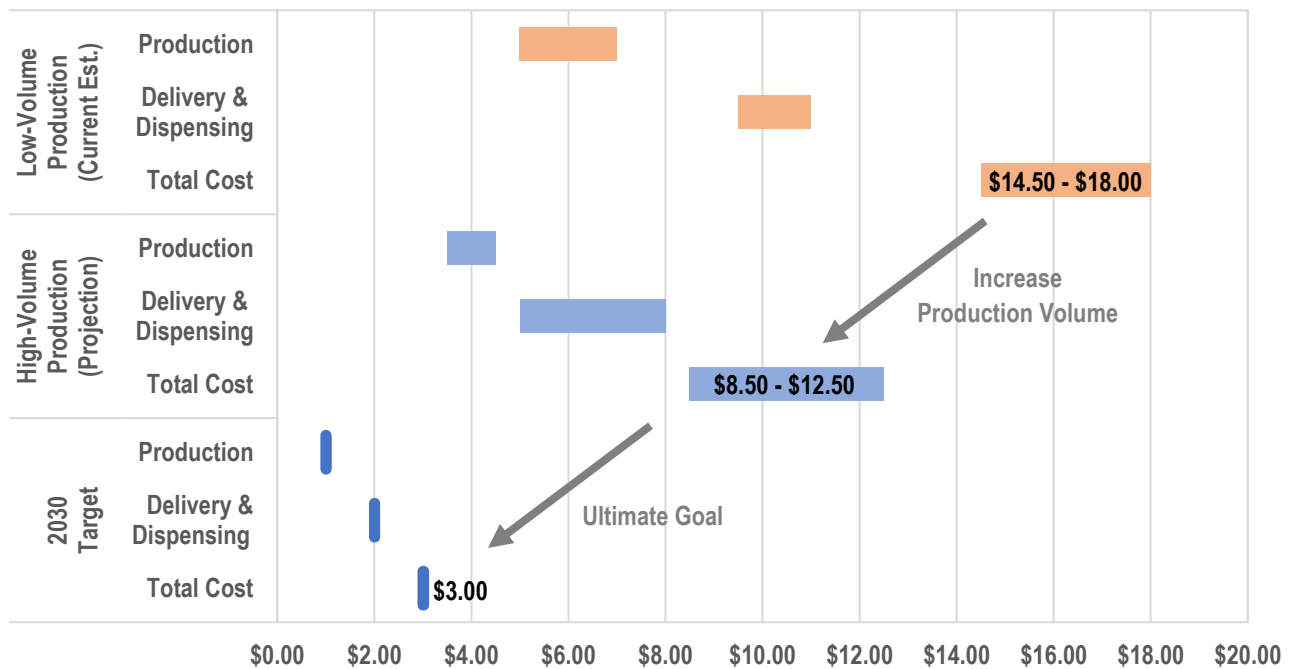

Figure 6: Estimated and Projected Clean Hydrogen Costs *Source: US DOE; All costs in 2016 Dollars*

Challenges Based on the State of the Technology

The majority of the hydrogen production in the United States is focused on gas supply for industrial processes such as ammonia production and petroleum refining. There is essentially no hydrogen fuel, especially low-carbon fuel, available for use by medium and heavy-duty FCEV trucks outside of California. Therefore, in order to support hydrogen truck refueling in Kentucky, hydrogen for this purpose would need to be produced and distributed in the region. Additionally, the current cost of clean hydrogen is not competitive with commonly used fossil fuels. In 2021 the US DOE launched a large initiative as part of the Earth Shots Program, which was coined the “[Hydrogen Shot](#)”. The main goal of this initiative is to target concerns around hydrogen’s cost competitiveness as a fuel. The program seeks to reduce the cost to produce 1 kilogram of hydrogen to \$1 in 1 decade (1-1-1). This would amount to an over 80% reduction in production costs compared to today’s prices.

The DOE followed this up with a revision to the [U.S National Clean Hydrogen Strategy and Roadmap](#) in 2023, which outlined several barriers which must be overcome in order to achieve this goal. Among the challenges outlined in this report were: the need to achieve price reduction through economies of scale, the need to further develop research and development (R&D) efforts to reduce the cost of electrolytic green hydrogen technologies, and the need to develop robust networks of hydrogen producers and consumers.

Many of the programs funded by the [Bipartisan Infrastructure Law \(BIL\)](#), such as regional hydrogen hubs, are aimed specifically at targeting these key challenges. In total \$9.5 billion was allocated toward the development of hydrogen infrastructure through this law. This includes funding for development of the regional hydrogen hubs as well as funding aimed at R&D efforts targeting improvements in hydrogen equipment manufacturing. Recently, seven selected hydrogen hubs were announced.

Industry Overview

This industry overview covers the four topics listed below and was informed by industry research as well as meetings with major industry stakeholders.

- Vehicle Manufacturing
- Hydrogen Production, Distribution, and Refueling
- Consumers Considering Hydrogen (delivery, trucking, & manufacturing industries)
- Hydrogen Research in Kentucky

Vehicle Manufacturing

There are several manufacturers of heavy-duty hydrogen powered fuel cell electric vehicles. They include companies such as Nikola, Toyota/Kenworth, Hyzon, Quantron and Hyundai. The heavy-duty long-distance trucks currently on the market tend to have listed typical driving ranges of 350 to 450 miles depending on the model. Some of the smaller trucks have shorter ranges, especially if they are special purpose vehicles like waste collection vehicles. For comparison, new diesel-powered long-haul tractors, given their large gasoline tanks, often can travel over 1,000 miles on a single fill-up.

Most of the hydrogen trucks currently on the road in the US are located in California. At present, all of the public hydrogen refueling stations in the country are located in California.

Toyota and Kenworth together manufacture a hydrogen powered heavy-duty FCEV truck with a range of approximately 450 miles. The fuel cells for this specific truck are manufactured in Georgetown, KY. Demonstration vehicles were used at the Port of Los Angeles, and the truck is expected to become commercially available in 2025.

Cummins in Columbus, IN has taken a different approach to the use of hydrogen fuel. They are collaborating with other companies to use hydrogen in internal combustion engines (ICE). However, this technology produces NO_x due to the high heat of the combustion of hydrogen, so it is not zero-emission at the point of use like hydrogen fuel cells.

Some of the vehicle manufacturers, either on their own or in partnership with other companies, work to supply hydrogen and refueling infrastructure to fuel the trucks they sell. One company offers mobile refuelers to customers while construction of the permanent infrastructure is completed. Another company is exploring the development of electrolyzers, fuel storage tanks, and other components that would support the transition to hydrogen for heavy-duty vehicles. The need to expand the refueling network (beyond centralized hub operations) was clear from discussions with one of the manufacturers.

During the discussions with one of the manufacturers, fuel availability surfaced as a major limitation on the demand for hydrogen powered trucks. Most current hydrogen production is assigned to, and needed by, existing industrial customers. There is little unallocated supply available for the transportation sector. This lack of available supply is irrespective of the “color” of hydrogen (**Table 2**), though green hydrogen is particularly hard to obtain.

Other limitations on the demand for hydrogen powered trucks include vehicle range, fuel cost, vehicle cost, safety, and reliability.

Hydrogen Production, Distribution, and Refueling

The hydrogen production, distribution, and public refueling infrastructure for trucks is currently very limited outside of California. There are only small private refueling facilities outside that state. The expansion of hydrogen fueling infrastructure to other states is a major goal for many entities, both public and private.

Current Kentucky Hydrogen Production

Currently, Airgas, an Air Liquide Company, produces commercially available hydrogen in Calvert City. Airgas produces 10 metric tons of liquid hydrogen per day using a fossil fuel-based process. The plant focuses on providing companies with a reliable supply of hydrogen for industrial processes in the Midwest region. Another producer is Air Products and Chemicals in Catlettsburg, KY. Air Products produces over 80 metric tons of hydrogen per day mainly, if not exclusively, for Marathon Ashland Petroleum.

Future Hydrogen Production in the Region

US DOE's Regional Clean Hydrogen Hubs (H2Hubs) program recently announced the selection of seven H2Hubs across the nation (**Figure 7**). These hubs will receive considerable funding to help expand low-carbon hydrogen production.

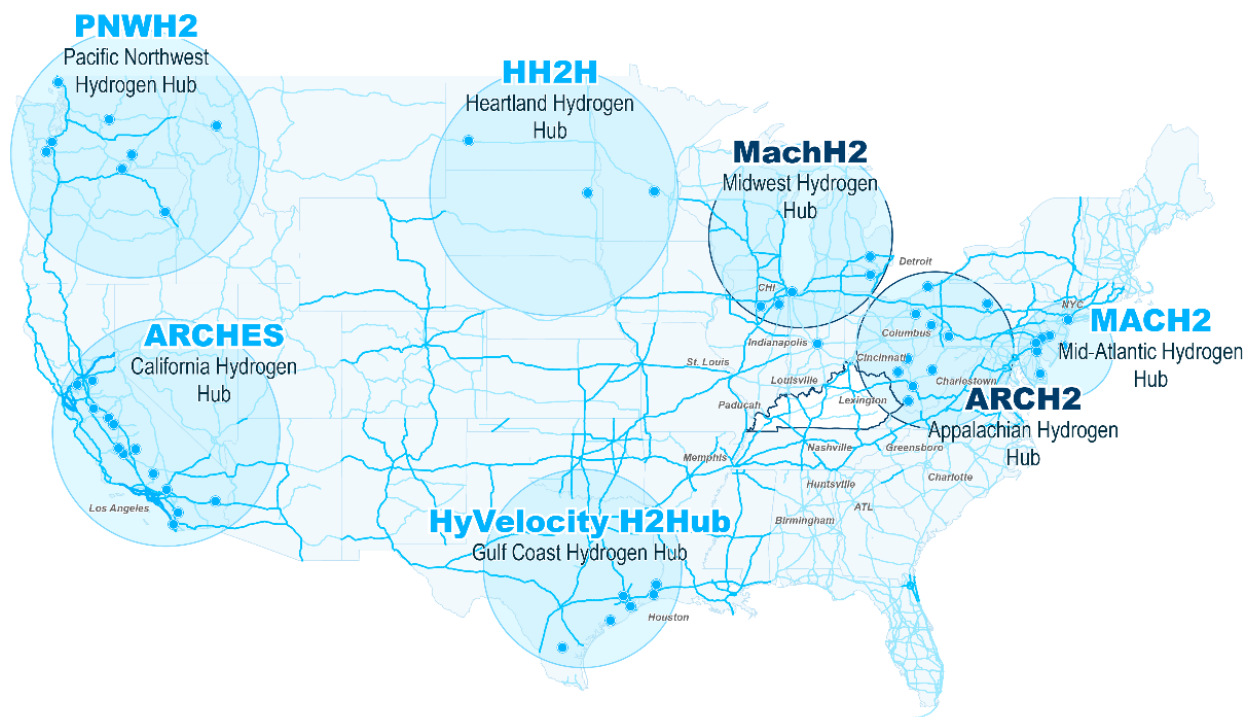

Source: HDR/DOE

Figure 7: US DOE's Regional Clean Hydrogen Hubs

There are two H2Hubs that could potentially provide fuel to Kentucky: ARCH2 and MachH2. The most likely of these is the ARCH2 hub with production facilities located in West Virginia, Ohio, and Pennsylvania. Kentucky is affiliated with this hub as a Community Support agency, as are the University of Kentucky and the Kentucky Community and Technical College System. Four of the planned West Virginia production facilities are listed below. There are others in West Virginia and Ohio that are within a few hours' drive of Kentucky.

1. Fidelis / Mountaineer GigaSystem - Mason County, WV (east of Ashland)
2. CNX / TransGas / Adams Fork Energy - Mingo County, WV (east of Pikeville)
3. TC Energy / Chemours - south of Charleston WV
4. TC Energy / Chemours - Parkersburg, WV

As Kentucky develops plans for hydrogen refueling stations in the state, it would be important to enter into discussions with ARCH2 regarding an offtake agreement to supply those stations. This could be an important part of a future plan and grant application to move the program forward.

The MachH2 hub has facilities planned for Illinois, Indiana, and Michigan. It may be more difficult to line up a hydrogen supply from this consortium, due in part to the northern locations for most of the planned production. Kentucky based companies and organizations, including the University of Kentucky, are members of the [MachH2 hub](#).

There are other firms in the Kentucky region that are working on developing hydrogen production capabilities. These include companies like [PCC Hydrogen](#), which is based in Louisville. PCC is focused on producing hydrogen using ethanol.

PPL, the parent company of LG&E and KU, is also working on hydrogen production at its research facility in Central Kentucky. While it does not yet produce commercial hydrogen, it is possible that they could be a future supplier.

Consumers Considering Hydrogen

There are several freight and/or manufacturing companies operating in Kentucky that are investigating the use of hydrogen as a zero-emission fuel. Some of these companies ship long-distances, some operate regional hub and spoke operations, and others do both. Through the course of discussions with these companies, it became apparent that there are several prerequisites for a firm to be interested in hydrogen fuel for medium- and heavy-duty trucks.

1. Large Trucking Operation with Sufficient Resources
2. Corporate Commitment to Net Zero
3. Funding to Support that Commitment

Based on research and discussions with company leaders the following topics surfaced as key challenges and opportunities.

Challenges

Reliability - For freight and manufacturing companies one of the most important attributes of a hydrogen refueling system is reliability. As one company representative stated, it is essential that a truck arriving to refuel can do so efficiently every single time. Down time of nearly any length was viewed as unacceptable as it would interrupt ongoing time sensitive operations.

Vehicle Availability – There are very few medium- and heavy-duty FCEV trucks on the market. Many models are only prototypes or have been manufactured in limited numbers. For example, Toyota and Kenworth partnered together and built 10 trucks that were tested in California. They expect their trucks to be commercially available in 2025.

Vehicle Cost – The most recently reported cost to produce a heavy-duty FCEV truck is \$679,000. It is expected that the potential near-term future purchase price will be \$750,000. This price is considerably higher than a standard diesel truck. It is expected that costs will come

down as the technology improves and production ramps up, but cost parity may still be 10 years or more away. Sources: [Hydrogen Insight](#); [FleetOwner](#); [Freight Waves](#)

Vehicle Range – Hydrogen FCEV trucks have typical listed ranges of 350 to 500 miles, which is less than half that of a typical diesel tractor truck. (Examples: [Hyzon](#), [Toyota/Kenworth](#), [Nikola](#)) As technology improves this difference could be reduced. Some firms have explored liquid hydrogen tanks to address this issue. Inadequate range is an issue for any “middle-mile” operations.

Fuel Availability – There is limited hydrogen fuel available and the fuel that is available tends to be high-carbon fuel that was produced from natural gas. Obtaining green hydrogen is very difficult and it is essentially not possible in Kentucky at present. There are also no public refueling stations at present.

Fuel Cost – Hydrogen fuel costs are several times the price of diesel fuel. Again, these costs are expected to decrease, but only over time. At present, the only way to lower the fuel costs is to tap into the federal subsidies that are available.

Public Fueling Infrastructure – There was considerable concern by at least one potential shipper related to public ownership of the fueling infrastructure. This firm was hesitant to participate in a public project where they could not control their own fueling infrastructure. There was concern based on prior experiences that the public agency would not be able to maintain the infrastructure adequately.

Competition from Electric Vehicles – One firm expressed that they are leaning toward electric vehicles, at least for deliveries. Electric vehicles are more available, charging infrastructure is further along, and the capital and operating costs for smaller electric delivery vehicles is closer to cost parity with ICE vehicles.

Ineffective Prior Pilots – One firm piloted the use of hydrogen for off-road tugs. They determined that the equipment did not meet their needs and discontinued the program.

On-Site Generation Concerns – Safety and cost concerns were raised by two firms regarding on-site hydrogen power generation.

Opportunities

New Hub Fuel Sources – The involvement of several public and private entities together could help secure hydrogen from one of the new hub operations, namely ARCH2. The partnership could provide more leverage for securing an offtake agreement.

Public Capital Funding – The public funding can cover up to 80 percent of the capital costs for any new installation.

Public Operating Subsidies – There are substantial public operating subsidies available.

Major Hub Operations and Manufacturing Centers – Kentucky is home to several major freight hub operations. These include Amazon and DHL at the Northern Kentucky/Cincinnati Airport and UPS at the Louisville Airport. There are also manufacturing hubs such as Toyota in Georgetown and Ford in Louisville. These facilities attract many trucks on a daily basis and many of those are regular suppliers.

Building and Warehouse Operations – Several firms mentioned the use of hydrogen to power forklifts and warehouse equipment. This familiarity supports further expansion to trucks.

Commitment to Net Zero – Several major firms have clear commitments to net zero carbon in fairly short time frames. This will require action on transportation emissions in the near-term.

Funds Allocated to Net Zero – Several firms have made substantial financial commitments and staffing commitments to achieving net zero. This financial and institutional backing makes hydrogen trucking a possibility.

Life Cycle Costs – There is interest in the life cycle costs of hydrogen fueled trucks and comparing that to diesel fueled trucks, instead of just looking at the capital costs and current operating costs (i.e., capital plus operating cost parity compared to diesel).

Hydrogen Research in Kentucky

University of Louisville

The University of Louisville's Conn Center for Renewable Energy Research and Christina Lee Brown Envirome Institute are leaders in hydrogen research in the state. The University of Louisville (UofL) also recently announced a major new tech hub, the Regional Energy Business, Education, & Commercialization Convergence Accelerator (REBECCA) Energy Strategy Development Consortium, which is funded by a \$500,000 grant from the U.S. Department of Commerce's U.S. Tech Hubs Program. The consortium includes the UofL J.B. Speed School of Engineering, Transit Authority of River City (TARC), Louisville Metro Government, Clariant and GE Appliances. Previously the group pursued, but was not awarded, a Charging and Fueling Infrastructure (CFI) Discretionary Grant to build a hydrogen fueling and electric vehicle charging station (**Figure 8**).

The facility proposed south of the JB Speed School of Engineering would pilot hydrogen production through digesters, pyrolysis, and an electrolyzer for storage and sale. One hydrogen fuel cell bus was included in the application. The site is not immediately adjacent to the interstate or major likely hydrogen purchasers, but freight operators were identified as potential customers.



Source: University of Louisville Conn Center for Renewable Energy Research

Figure 8: Proposed Hydrogen Fueling Station and EV Charging Station at U of L

PPL

[PPL](#), the parent company for utility companies Louisville Gas and Electric (LG&E) and Kentucky Utilities (KU) is a sponsor of the Electric Power Research Institute (EPRI) Low-Carbon Resource Initiative to accelerate the development of low-carbon electric generation technologies and low-carbon energy carriers such as hydrogen. In coordination with the University of Kentucky Center for Applied Energy (CAER), EPRI, LG&E and KU have developed clean electricity generation capabilities at the pilot scale at the E.W. Brown Generating Station between Harrodsburg and Nicholasville, Kentucky. This project utilizes a heat-integrated, post combustion CO₂ capture system for applications at coal fired plants. This consortium is also working on a project that focuses on producing clean hydrogen while capturing carbon dioxide directly from the air.

University of Kentucky

The University of Kentucky [Center for Applied Energy Research \(CAER\)](#) was created to implement a research program to develop new and more effective and environmentally acceptable uses of fossil fuels and other natural resources found within the state. The center focuses on applied research and development. CAER has established a small pilot (0.7MWe) post-combustion carbon capture and storage (CCS) system in partnership with PPL (KU) at the E.W. Brown Generating Station in Harrodsburg, Kentucky. CAER may scale up this technology to a large pilot system at a PPL (LG&E) power station in Trimble County in the future.

Kentucky Energy and Environment Cabinet

EEC has also partnered to explore the use of Class VI wells for geologic carbon sequestration. This research/testing has examined the potential for this approach to provide a means of capturing and storing carbon to be able to use fossil fuels to create low carbon hydrogen.

Industry Overview Conclusions

There are several key constraints to the adoptions of hydrogen-power trucks.

- Fuel Availability and Cost
- Vehicle Availability and Cost
- Vehicle Range
- Refueling Station Availability and Reliability
- Refueling Station Cost
- Competition from Electric Vehicles
- Concerns from Prior Pilot Projects

There are also several opportunities.

- Private Partners with Commitments to Achieve Net Zero
- Private Partners with Funding and Resources to Achieve Net Zero
- Public Funding for Capital and Operating Expenses
- New Hub Hydrogen Fuel Sources
- Major Distribution and Manufacturing Centers
- Ongoing Research and Development
- Life Cycle Costs

Federal and State Programs and Initiatives

There are several federal initiatives designed to advance the use of hydrogen for fueling medium- and heavy-duty trucks. Most of these are funded by the Bipartisan Infrastructure Law (BIL) or the Inflation Reduction Act (IRA). These two pieces of legislation include federal formula funds, competitive grant programs, and other incentives designed to support government agencies and private firms in their efforts to implement hydrogen fueling systems for freight. There are billions of dollars available through the various new funding sources. The goal for these programs is to make the reduction in transportation sector carbon emissions possible.

U.S. Department of Transportation (USDOT)

Hydrogen Alternative Fuel Corridors

Over the last several years, USDOT’s Federal Highway Administration (FHWA) has established a federally designated national network of [Hydrogen Alternative Fuel Corridors](#) (AFCs). In Kentucky, the Hydrogen AFCs include the major long-distance interstates: I-64, I-65, I-71, I-75, I-24, I-69, and I-165 as shown on **Figure 9** and **Figure 10**. The adjoining states of Tennessee and West Virginia also designated hydrogen AFCs that connect to Kentucky along I-24, I-65, I-75, and I-64. States to the north have not yet designated hydrogen AFCs that connect to Kentucky.

Kentucky’s hydrogen AFC designations allow the state to pursue “corridor” funding for public hydrogen stations along these highways. Per the federal AFC guidance, the ultimate goal would be to construct public hydrogen fueling stations on these corridors that are no more than 150 miles apart (in any logical direction of travel) and no more than 5 miles from the nearest interchange or intersection on the AFC. Once that is achieved for a corridor, it would be considered “built-out”.

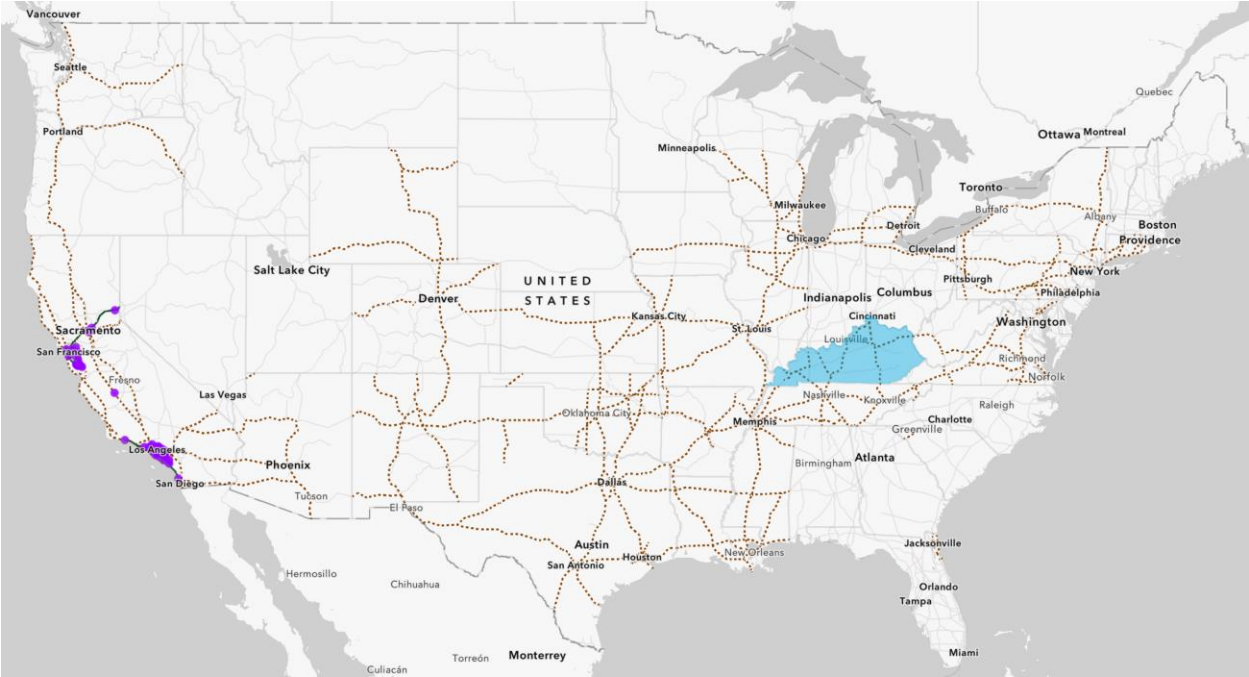

Source: USDOT, HDR

Figure 9: National Federally Designated Hydrogen AFCs

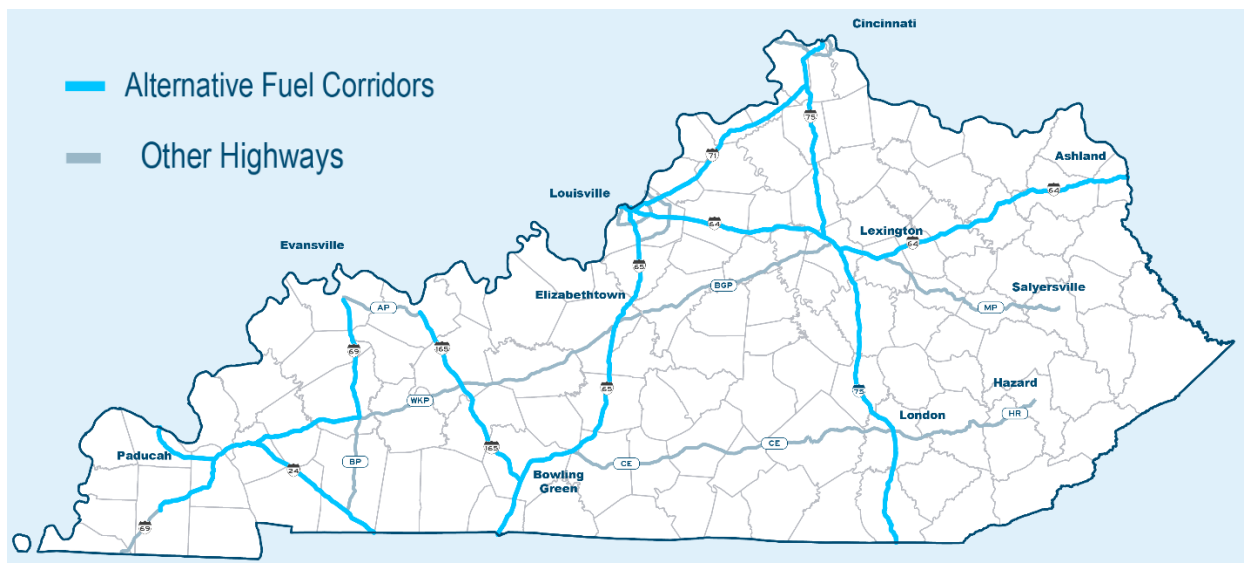

Source: HDR

Figure 10: Kentucky’s Federally Designated Hydrogen AFCs

Charging and Fueling Infrastructure Program

BIL authorized \$2.5 billion over five years for public agencies to deploy publicly accessible alternative fuel infrastructure. To distribute these funds, FHWA established the competitive [Charging and Fueling Infrastructure \(CFI\) Discretionary Grant Program](#). The CFI Program is divided into two types: Community Program Grants (minimum award of \$500,000 and maximum of \$15 million) and the Corridor Program Grants (minimum award of \$1 million with no maximum award size). Applicants must provide at least a twenty percent non-federal match to the CFI Program award. While the majority of the program’s emphasis has been on electric vehicle charging infrastructure, hydrogen refueling infrastructure is also eligible.

FHWA [awarded \\$622.57 Million to 47 applicants](#) in the first round of the CFI Program (this first award was for FY 2022 and FY 2023). Included in this award were four hydrogen refueling projects, two in California, one in Colorado, and one in Texas (**Figure 11**).

- **Workforce and Renewable Hydrogen for Light- to Heavy-Duty Zero Emission Vehicle (ZEV) Fueling in DAC**
- **Pathway to the Future: Barstow’s Hydrogen and Charging Infrastructure Project**
- **Colorado with Hydrogen Refueling Infrastructure on the I-25 Corridor (Hy-25)**
- **Charging and Fueling Infrastructure (CFI) Corridor Program for the Texas Hydrogen and Electric Freight Infrastructure project**

“The North Central Texas Council of Governments will receive \$70 million to build up to five hydrogen fueling stations in the Texas Triangle, which includes Dallas-Fort Worth, Houston, Austin, and San Antonio. The stations will create a hydrogen refueling network for medium- and heavy-duty freight trucks.” ([USDOT CFI grant award list](#))

The Texas project is potentially a good model for securing this type of funding. This award was preceded by early hydrogen station planning and involved a solicitation of partners to support the stations. The grant also serves several regions, which is consistent with the size of the award.

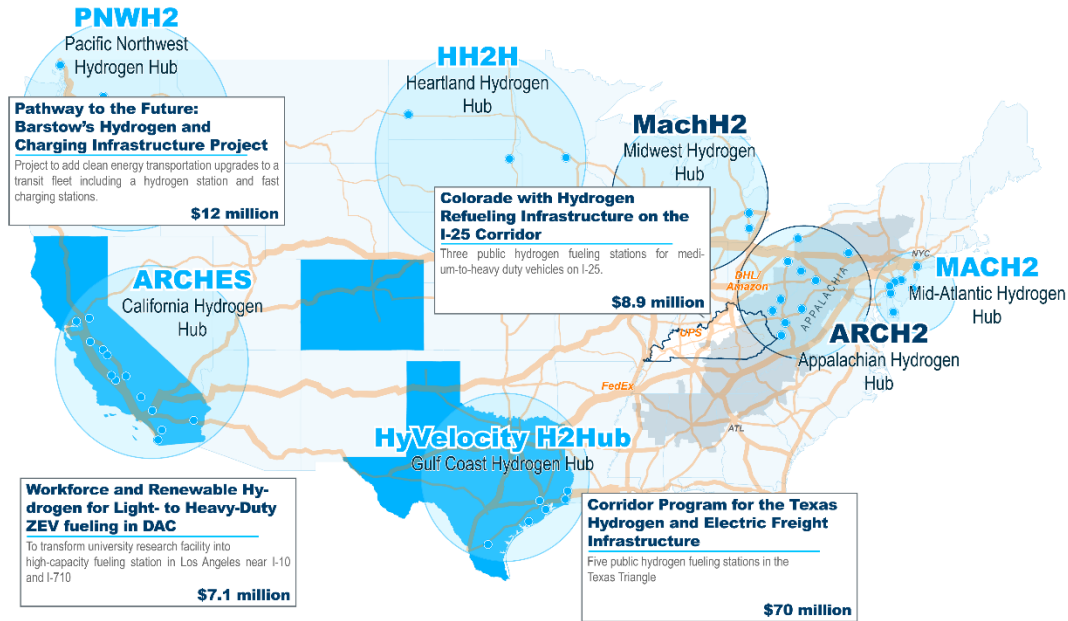

Source: HDR

Figure 11: CFI Hydrogen Refueling Stations Awarded in 2024

The North Central Texas Council of Governments Metropolitan Planning Organization (NCTCOG) announced a Call for Partners in March 2023¹ to establish a public-private partnership to develop medium- and heavy-duty ZEV infrastructure project proposals. Both Hydrogen and battery electric solutions were eligible. Highways in the area of interest appeared on the electric and hydrogen alternative fuel corridors. The initiative coordinated with the local Clean Cities Coalition to position for federal grant programs to build out the Zero Emission Vehicle Plan for Interstate 45.

The next CFI Notice of Funding Opportunity (NOFO) is expected in Summer 2024. With awards for hydrogen fueling stations going to only western or central states in the first round, applications from eastern states may be viewed favorably in the next round.

National Zero-Emission (ZEM) Freight Corridor Strategy

On March 12, 2024 the Joint Office of Energy and Transportation, in collaboration with the U.S. Department of Transportation, U.S. Department of Energy, and the Environmental Protection Agency, released the *National Zero-Emission Freight Corridor Strategy*. That strategy proposes an actionable plan to develop a zero-emission freight network across the United States by 2040. Hydrogen truck refueling infrastructure serving freight hubs and along major freight corridors is a critical part of the plan. The plan includes four phases as shown in **Figures 12 through 15**.

¹ North Central Texas Council of Governments Metropolitan Planning Organization Call for Partners March 2023 <https://www.nctcog.org/getmedia/f8a04c31-e3cb-4773-b2ed-d022d9a28079/ChargingAndFueling-CFPartners-FINAL.pdf>

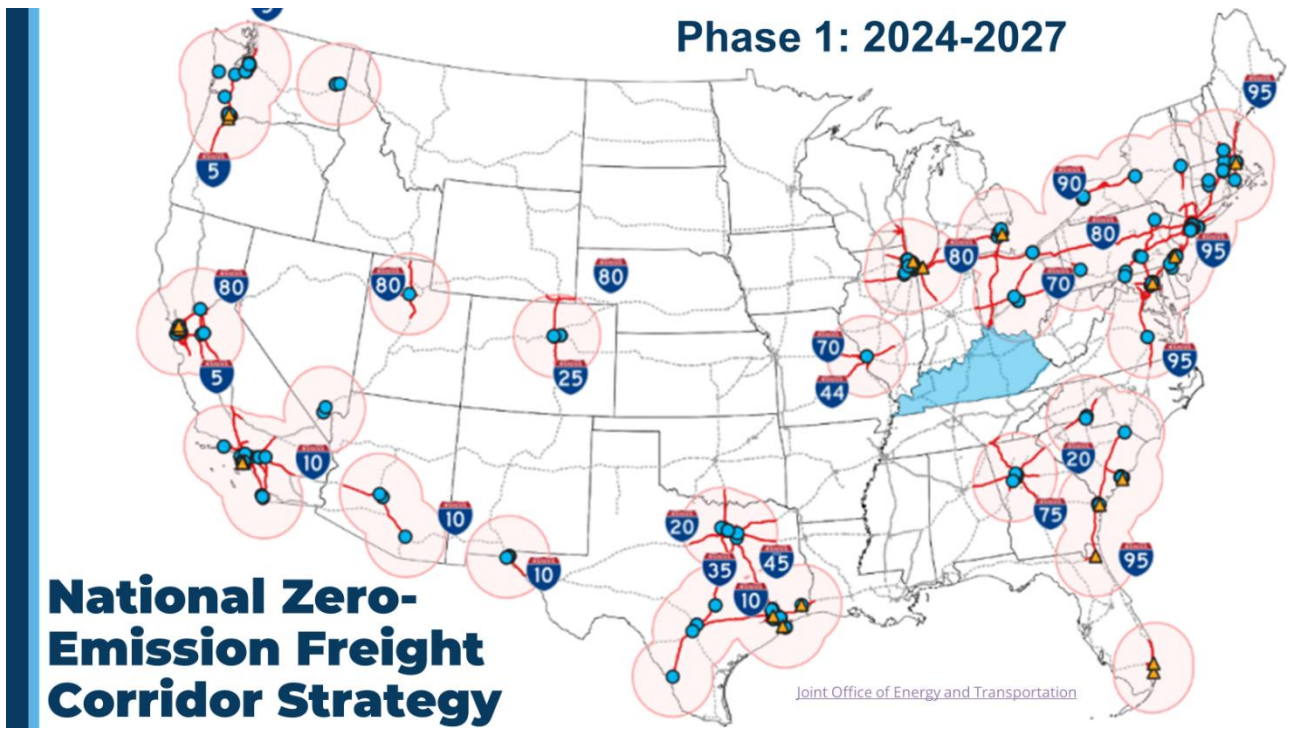

Figure 12: National ZEM Freight Corridor Strategy Phase 1



Figure 13: National ZEM Freight Corridor Strategy Phase 2

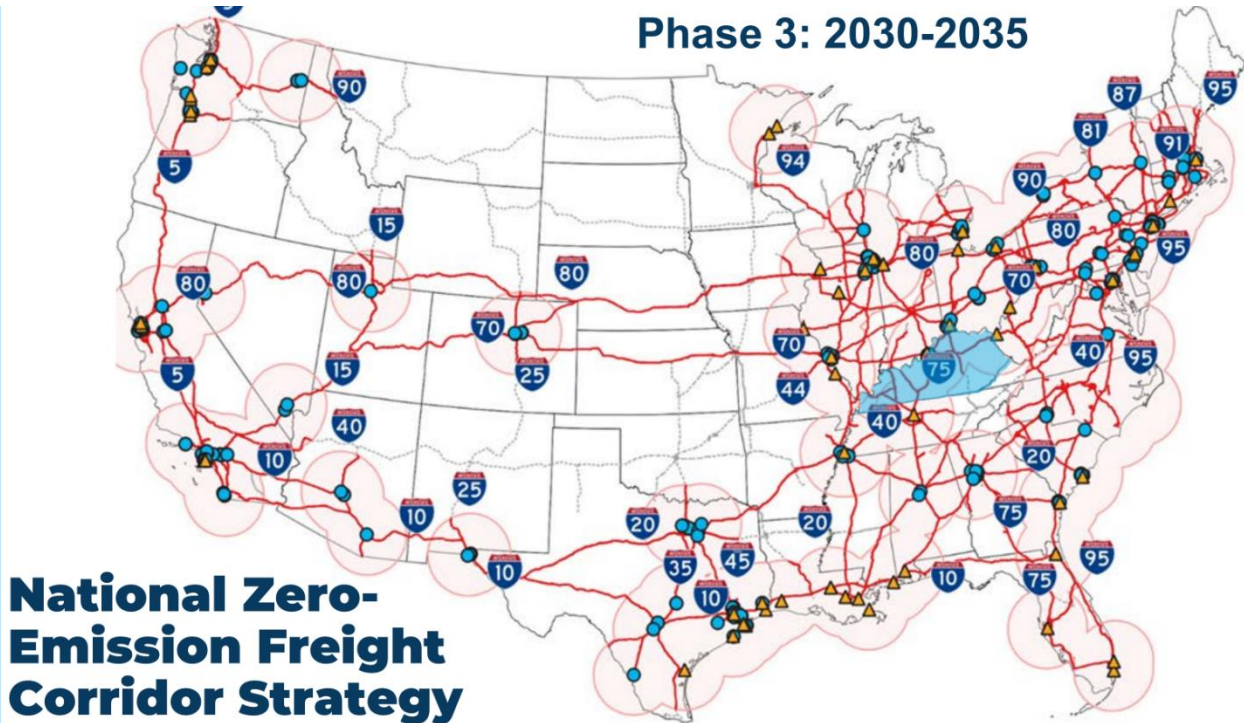

Figure 14: National ZEM Freight Corridor Strategy Phase 3

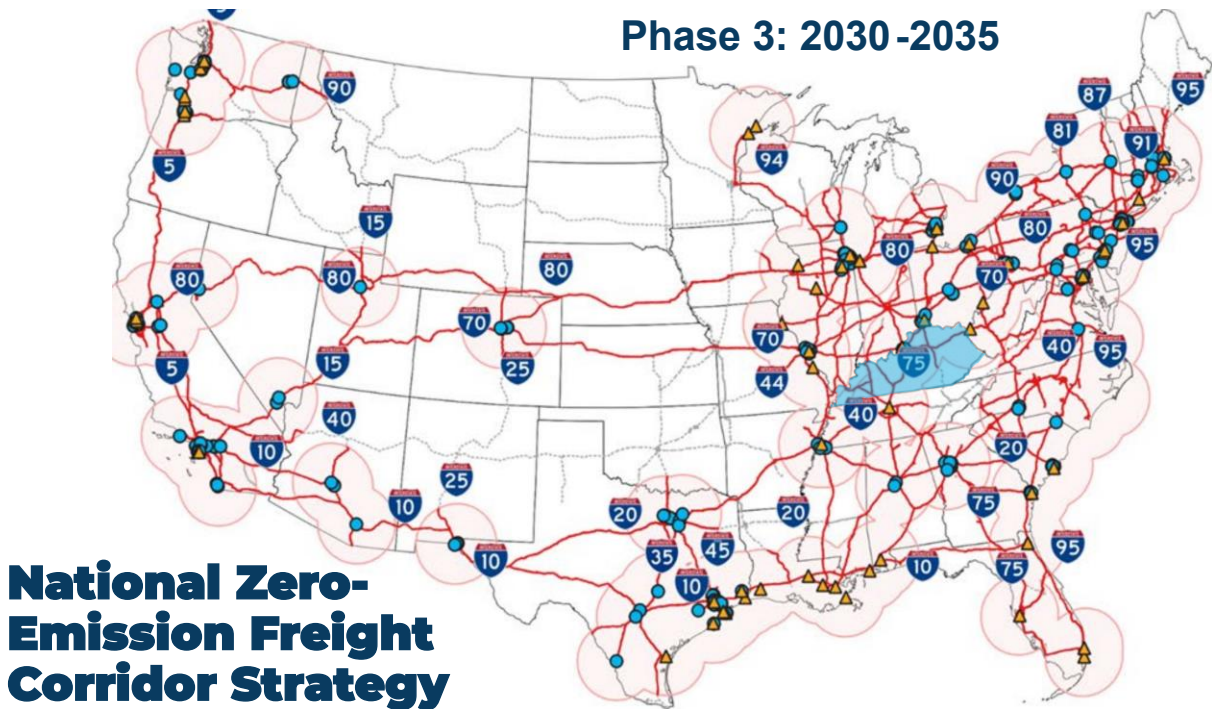

Figure 15: National ZEM Freight Corridor Strategy Phase 4

Kentucky is currently not included in the strategy until Phases 3 and 4, though there are good reasons to include Kentucky as part of Phase 2 as illustrated by **Figure 16**. One reason is the considerable flow of freight in the state, particularly on I-65. Another is that there are no north-south routes in Phases 1 and 2 between I-15 in Nevada/Utah and I-95 in Virginia. I-65 provides a critical north-south link that could meet that need.

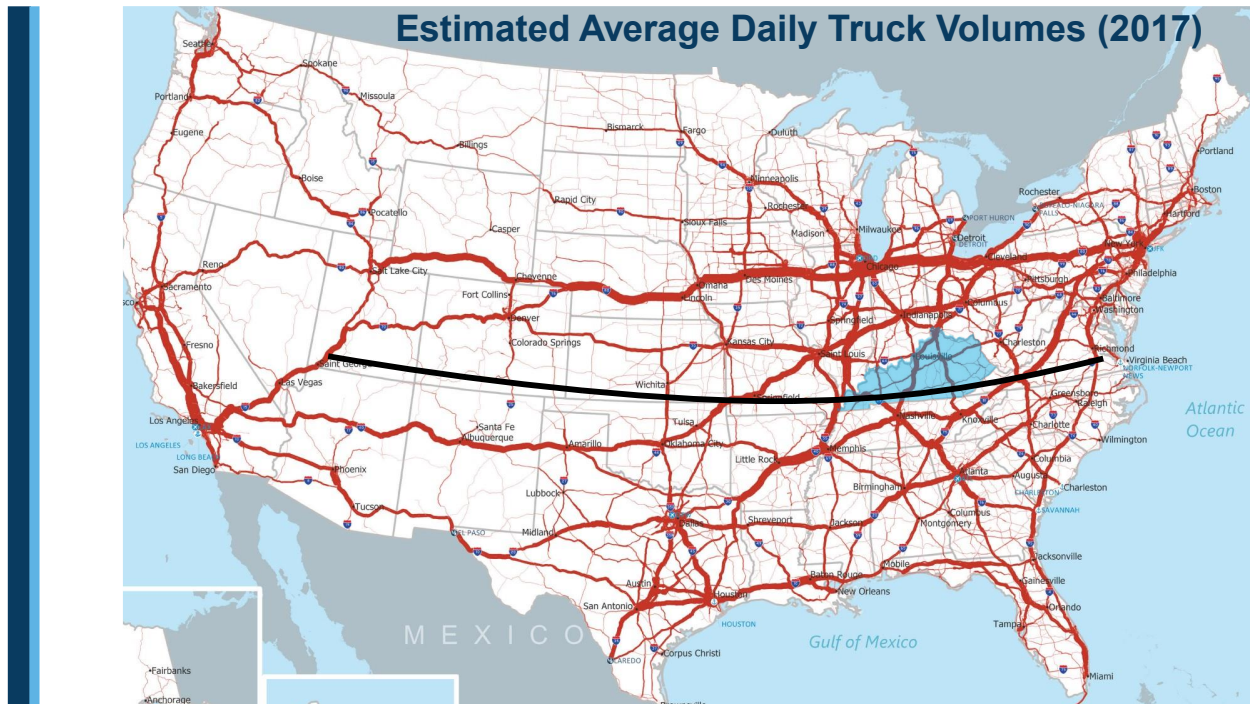

Figure 16: CFI Hydrogen Refueling Stations Awarded in 2024

Other USDOT Initiatives

There are other USDOT programs that could be used to fund hydrogen fueling infrastructure, but many of them are very competitive both inside and outside the state, making them unlikely to be good avenues for funding hydrogen projects. However, one program worth mentioning is the Carbon Reduction Program (CRP), as it is specifically aimed at reducing carbon emissions. This is a FHWA formula fund program with funds allocated to KYTC and all Metropolitan Planning Organizations (MPOs) across the state.

U.S. Department of Energy (US DOE)

Regional Clean Hydrogen Hub Program

The most significant US DOE program is the Regional Clean Hydrogen Hub Program run by the Office of Clean Energy Demonstrations (OCED). This program is aligned with US DOE's [National Clean Hydrogen Strategy and Roadmap](#) (June 2023).

In October of 2023 multiple federal agencies joined in the announcement of seven hydrogen hubs (H2Hubs) across the country (**Figure 17**). To be selected each H2Hub must produce at least 50-100 metric tons of clean hydrogen per day.

Kentucky joined three H2Hub grant applications. The application for a production facility in the state using steam-methane reforming (involving the University of Kentucky and PPL) was not

selected. However, Kentucky does have an arrangement with two of the H2Hubs that were selected² in surrounding states: the Appalachian Regional Clean Hydrogen Hub ([ARCH2](#); with projects in West Virginia, Ohio, and Pennsylvania) and the Midwest Alliance for Clean Hydrogen Hub ([MachH2](#); with projects concentrated in Illinois, Indiana, and Michigan).

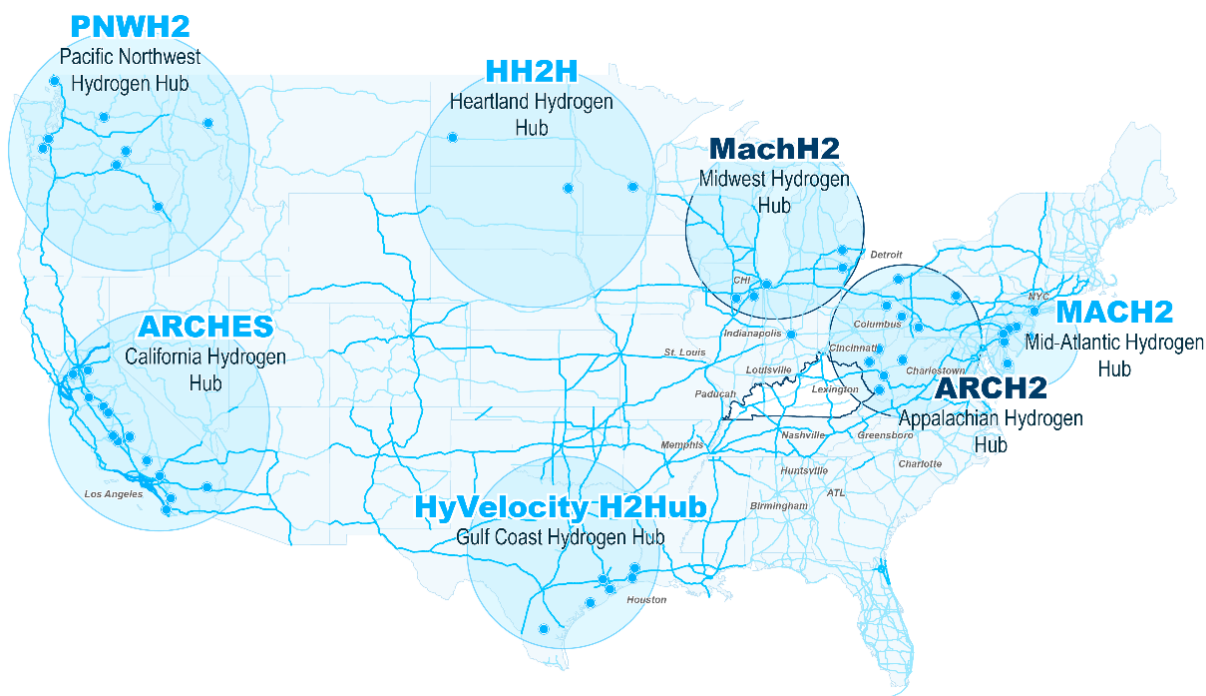

Source: HDR

Figure 17: Regional H2Hubs with Alternative Fuel Corridors for Hydrogen

The ARCH2 sites are clustered around the Ohio River Valley in areas of Appalachia known for coal and natural gas extraction. ARCH2 partners in Ohio include transit agencies and distribution centers. Sites included in the MachH2 announcement lie near Chicago, IL and Detroit, MI. The H2Hub sites in Michigan will include transit applications and the “H2 Truck Stop of the Future.” The Midwest Hydrogen Corridor Coalition proposed a project in Indianapolis as part of MachH2.

The Hydrogen and Fuel Cell Technologies Office (HFTO) under the Office of Energy Efficiency and Renewable Energy (EERE) within the US DOE focuses on development of clean hydrogen across business sectors.

H2Hubs Demand-side Initiative

A complementary aspect of the H2Hubs program would create market certainty for hydrogen production by developing measures to assist the demand side. Responses to a request for proposals for the demand-side initiative to accelerate clean hydrogen were due in October 2023. In January 2024, the US DOE Office of Clean Energy Demonstrations (OCED) announced a [consortium of partners to implement the program](#). The consortium will provide the financing and exchange framework for fueling station operators. The production of hydrogen fuel is incentivized by the H2Hubs and Federal tax programs. This demand-side support will “bridge the gap”

² U.S. Department of Energy (USDOE) Office of Clean Energy Demonstrations, Regional Clean Hydrogen Hubs Selections <https://www.energy.gov/oced/regional-clean-hydrogen-hubs-selections-award-negotiations>

between the producers who require offtake commitments to secure funding to build a project and the buyers who operate on shorter time scales when making their energy purchasing decisions. Stabilizing production, making fuel available reliably, and bringing down costs to produce, store, and purchase are keys to expanding hydrogen as an alternative fuel.

Other Federal Programs and Incentives

The Alternative Fuels Data Center (U.S. Department of Energy, Energy Efficiency and Renewable Energy) compiles a list of laws and incentives at the Federal level.³ There are also other programs by agencies such as the US Environmental Protection Agency and loan programs by US DOE.

IRC 48C Advanced Energy Project Credit – The Inflation Reduction Act (IRA) established the [Advanced Energy Production Credit](#) for manufacturers and other entities to invest in qualifying advanced energy projects. The program offers an investment tax credit of up to 30%. Four billion of the ten billion dollars allocated for the program is set aside for [designated energy communities](#), including predominately rural communities in Kentucky (see **Figure 18**). Qualifying projects include clean energy manufacturing and recycling (including vehicles); critical materials refining, processing, and recycling; and GHG emission reduction at industrial facilities.

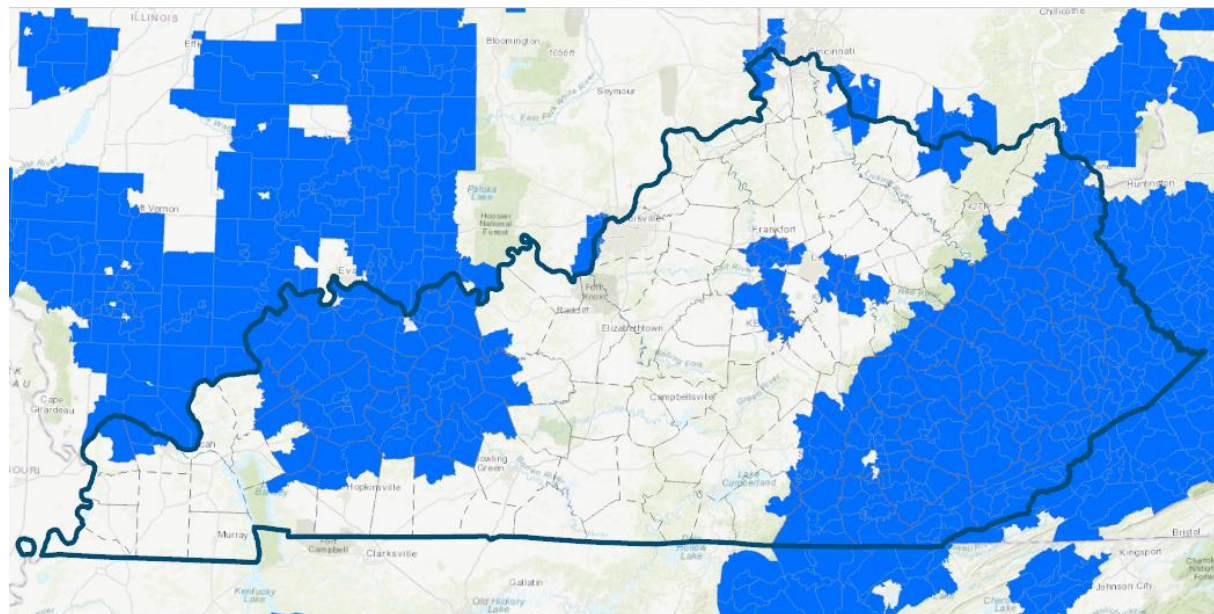

Figure 18: Designated Energy Communities (IRC 48C)

IRC 45V Clean Hydrogen Production Tax Credit - The Inflation Reduction Act (IRA) established a Credit for the Production of Clean Hydrogen. Hydrogen producers may claim a tax credit in any year qualified clean hydrogen is produced for sale. The amount of the credit is based on the lifecycle greenhouse gas emitted in the process, ranging from \$0.60/kg to \$3.00/kg of hydrogen produced. Portions of the law are administered in the tax code by the IRS under Internal Revenue Code (IRC) 45V. The code establishes standards by which hydrogen is produced as fuel by enacting a tiered system where higher credit amounts are available to producers leveraging specific low-carbon production methodologies. The tiered incentives favor production of hydrogen from renewable energy and provide an additional incentive for the development of hydrogen

³ U.S. Department of Energy, Alternative Fuels Data Center, Laws and Incentives <https://afdc.energy.gov/laws/11675>

production in areas with a large penetration of renewable energy production. Developments meeting the most rigorous requirements outlined by the law (i.e. lowest carbon intensity) may be able to claim the maximum credit of \$3/kg produced. Entities operating in the states on the eastern half of the country, including Kentucky, may encounter difficulties adhering to this standard and receiving the full benefit based on the lower penetration of renewable energy in this area's electric grid.

IRC 45W Clean Vehicle Tax Credit - The IRC Clean Vehicle Tax Credit of up to 30% or \$40,000 for hydrogen-powered FCEV trucks over 14,000 lbs is available to businesses and tax-exempt organizations who purchase a clean vehicle from a qualified manufacturer. Manufacturers include major bus and truck manufacturers. The credit is based on gross vehicle weight ratings, fuel consumed, and ownership stake in the vehicle.

IRC 45Q Tax Credit for Carbon Sequestration – This tax credit offers \$60 to \$180/metric ton of CO₂ sequestered.

Alternative Fuel Excise Tax Credit (IRS) was extended through December 31, 2024. This is a tax incentive of \$0.50 per gallon for alternative fuel that is used to operate a motor vehicle.

Alternative Fuel Infrastructure Tax Credit (IRS) as of January 1, 2023, fueling equipment for hydrogen is eligible for 30 percent of the cost or 6 percent in the case of depreciation, not to exceed \$100,000.

Commercial Electric Vehicle and Fuel Cell Electric Vehicle Tax Credit (IRS) Fuel Cell vehicles with a Gross Vehicle Weight Rating over 14,000 pounds with a battery capacity of at least 15 kWh may be eligible for 30 percent of the purchase price.

Electric Vehicle and Fuel Cell Electric Vehicle Manufacturing Tax Credit (IRS) for projects that re-equip, expand, or establish a manufacturing facility to produce or recycle light-, medium-, and heavy-duty FCEV and hydrogen fueling stations.

Fuel Cell Motor Vehicle Tax Credit (IRS) a tax credit of up to \$8,000 is available for the purchase of fuel cell vehicles. Additional credits, based on vehicle weight are available for medium- and heavy-duty vehicles.

Electric Vehicle and Fuel Cell Electric Vehicle Manufacturing Loans (US DOE) provides grants or loan guarantees through the Loan Guarantee Program for the domestic production of hydrogen fuel cell vehicles.

Advanced Technology Vehicles Manufacturing Loan Program (ATVM) (US DOE) This program provides loans to support the manufacture of eligible advanced technology vehicles and qualifying components, including medium- and heavy-duty vehicles.

EPA Clean Ports Program (US EPA) The IRA provided the Environmental Protection Agency with \$3 billion to fund zero-emission port equipment and infrastructure as well as climate and air quality planning at U.S. ports. They have issued notices of funding availability for two programs: *Zero-Emission Technology Deployment Competition* and the *Climate and Air Quality Planning Competition*.

Kentucky Incentives and Assistance

Energy and Environment Cabinet

The EEC Office of Energy Policy (OEP) is working with the National Association of State Energy Officials (NASEO) and other state energy offices on hydrogen development. This includes participation in the NASEO Clean Hydrogen State Working Group. OPE is also an advisor working with NASEO on the National Clean Hydrogen Strategy. That initiative covers five topics:

1. Components for Hydrogen Fueling of Medium-and Heavy-Duty Vehicles
2. Standardized Hydrogen Refueling Station of the Future
3. Hydrogen Fuel Cell Powered Port Equipment
4. Enabling Permitting and Safety for Hydrogen Deployment
5. Equitable Hydrogen Technology Community Engagement

OEP is part of the permitting and safety committee. Through the NASEO workgroup, OEP shares information and explores opportunities for collaboration on future hydrogen fuel initiatives.

Cabinet for Economic Development

Kentucky has developed financial assistance and tax credit programs for businesses that advance the development of alternative fuels. Of the incentives administered through the Kentucky Cabinet for Economic Development (CED), those that most closely align with hydrogen include:

Kentucky Business Investment (KBI) Program is an income tax credit incentive to any new or existing business entity engaged in alternative fuel, gasification, energy-efficient alternative fuels, or renewable energy production. These incentives also apply to activities that include carbon dioxide or hydrogen transmission pipeline. The company must create new, full-time jobs in Kentucky and make a minimum investment (\$100,000) in the eligible activity.

Kentucky Enterprise Initiative Act (KEIA) is a sale and use tax incentive for any new or existing business engaged in alternative fuel, gasification, energy-efficient alternative fuels, or renewable energy production. These incentives apply to activities that include carbon dioxide or hydrogen transmission pipeline and tourism, research and development, and data processing equipment. The company must make a minimum investment (\$500,000) in the eligible activity in Kentucky.

Kentucky New Energy Ventures Fund (KNEV) exists to stimulate investment in technology, particularly, the development and commercialization of alternative fuel and renewable energy products in Kentucky. KNEV invests in companies with high-growth potential starting at \$250,000 and exceeding \$750,000.

Manufacturing Tax Advantages applies to energy and energy-producing fuel used as part of a manufacturing process which may be eligible for sales and use tax saving.

Title 17 Clean Energy Financing – State Energy Financing Institution (SEFI) – Kentucky does not currently have a SEFI, but this could be an avenue for project financing in the future if a SEFI were to be set up.

Market Demand

Currently there is very little demand for hydrogen fuel for medium and heavy-duty FCEV trucks in the US outside of California. There are some pilot tests that have been conducted, but there are no permanent users. As noted previously, there is also no public hydrogen fueling infrastructure outside of California. This situation presents a substantial challenge and is why the federal government has attempted to set up both supply side and demand side initiatives.

General Freight Flows in Kentucky

In Kentucky, freight movement is a major driver for the economy (**Figure 19**). This includes significant both long-distance and regional hub trucking operations. Kentucky has leveraged its centralized location to attract manufacturing and shipping companies who rely on expedient delivery. There are especially large flows on I-65, I-75, and I-24. However, constructing stations to build out the hydrogen AFCs in Kentucky based upon capturing a percentage of truck traffic is a long-term consideration. Only after the market grows further would it be feasible to install hydrogen fueling stations without commitments for the purchase of the fuel.



Figure 19: 2017 Truck Flows in Kentucky and Surrounding States.

Kentucky in the National Context

Kentucky's position within the national context of the new hydrogen hubs and current truck freight flows is illustrated on **Figure 20**. The major freight flows are measured by daily volumes for all commodities for trucks on the National Highway System in 2017 (USDOT FHWA Freight Analysis Framework version 5.1). The freight flows in Kentucky are moderate compared to those in several other nearby states, but they are still significant. Northern Kentucky – Cincinnati is the point on the map where heavy lines from Chicago (I-65 and I-74), Detroit (I-75), and Cleveland (I-71) converge. Louisville to Nashville (I-65) – continuing from Cincinnati on I-71 and through Nashville to Memphis (I-40) or Atlanta (I-24 to I-75) also show high freight flows.

Hydrogen Fueling Stations

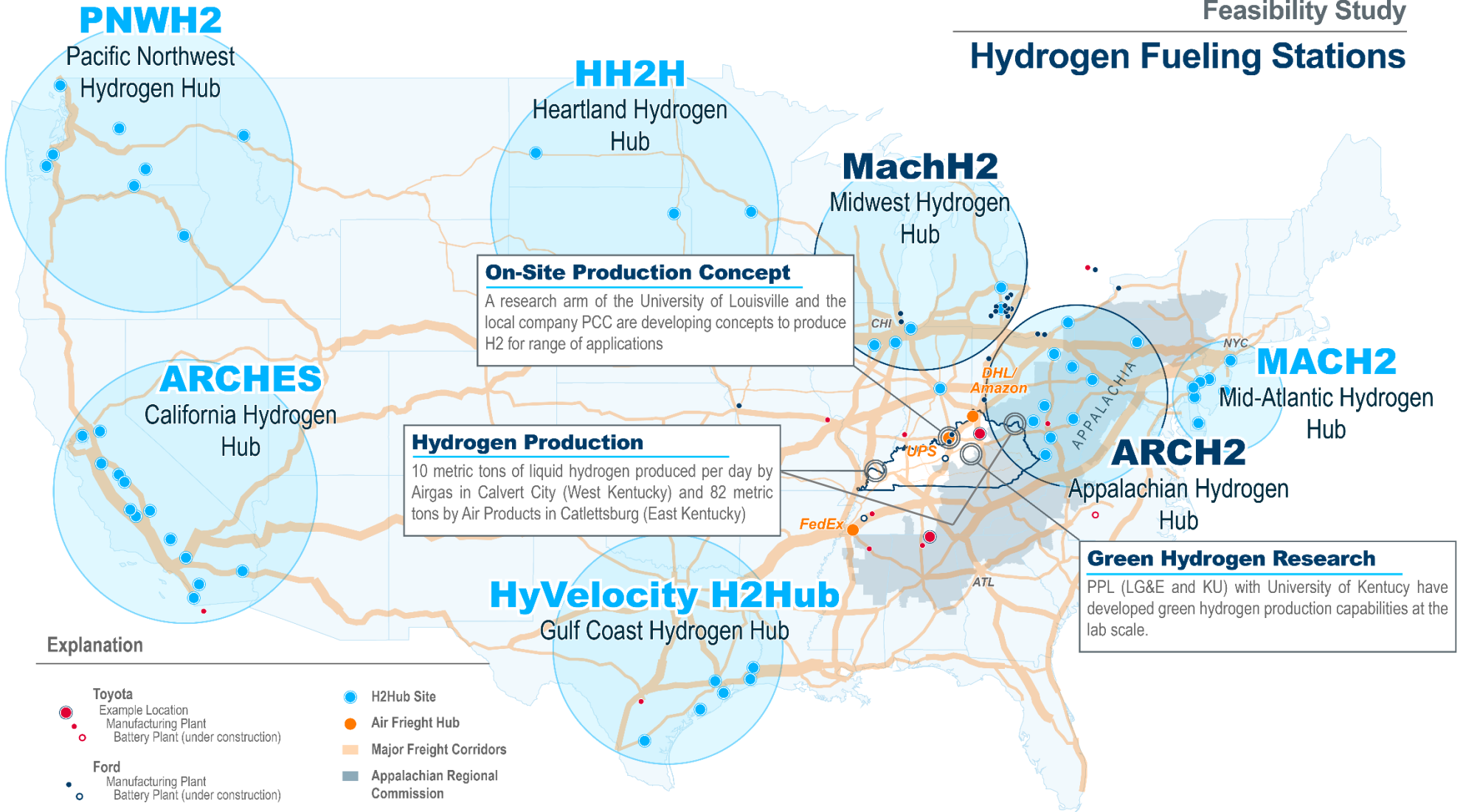

Figure 20: Kentucky's Hydrogen Landscape Within the National H2Hub Context

Partnership Opportunities in Kentucky

New hydrogen hub facilities, air freight hubs, automotive manufacturing, and other activity centers are illustrated on **Figure 21**. This figure shows potential opportunities and partnerships related to hydrogen as a transportation fuel. At this early stage, a few key partners could be crucial in advancing the industry forward.

Many large industrial and freight focused companies are located in Northern Kentucky, Lexington, and Louisville. Other regions of the state do not have that same high density of potential hydrogen fuel partners. Therefore, the feasibility study focused on those areas and on companies that have expressed interest in hydrogen fuel for medium and/or heavy trucks and met the three criteria listed at the outset of this chapter.

Major Freight Shipping Operations

Parcel delivery companies with global operations have located their North American air hubs at the largest airports in the state. UPS Worldport is located at Louisville's Muhammad Ali International Airport (SDF) on the Interstate 65 corridor. Amazon and DHL have located their air hub operations at Cincinnati/Northern Kentucky Airport (CVG), along the I-71/I-75 corridor. These companies operate long haul (tractor trailers) and make deliveries (box trucks).

All three of these companies have net zero carbon and sustainability goals and have implemented or at least explored hydrogen transportation or warehousing initiatives aimed at reducing carbon emissions. For example, DHL continues to test hydrogen fuel in many of the vehicle types in operation in the world.

Kentucky also has seven operating public river ports and four more river ports in development. It also has over 2,600 miles of rail line and over 80 rail yards. These river and rail freight facilities are critical to distributing energy and manufactured products. However, they tend to generate moderate truck traffic as a considerable portion of the fuel for energy production (coal, natural gas, and oil) is shipped by water, rail, or pipeline.

Manufacturing Operations

Kentucky lies in the middle of "Auto Alley". The most significant operations in Kentucky are associated with Toyota, Ford, and General Motors and major component manufacturing and vehicle assembly plants for those brands are included on the map. These companies also have net zero carbon and sustainability goals and have implemented or explored hydrogen transportation initiatives. For example, Toyota has partnered with Kenworth to develop heavy-duty hydrogen powered trucks and Ford is currently testing a hydrogen delivery van prototype in Europe.

Other Opportunities

The state has a long history in energy production, namely the coal and natural gas found in the Appalachian Mountain Region. Hydrogen production for industrial purposes is occurring in Calvert City, along the I-24/I-69 corridor and in Eastern Kentucky in Catlettsburg. The major public utility operating in the state, PPL (LG&E and KU) is working with the University of Kentucky on the production of hydrogen in Central Kentucky. The energy research arm of the University of Louisville and private industry are pursuing novel technologies to produce hydrogen, apply federal grant/incentive programs, and develop partnerships.



Figure 21: Hydrogen Landscape in Kentucky

Regional Considerations

NORTHERN KENTUCKY

The major airport serving the region, Cincinnati/Northern Kentucky International Airport (CVG), serves as the US air freight hub for Amazon and DHL. Amazon has a distribution warehouse serving homes and businesses in the region. DHL tested hydrogen support vehicles at the airport and the airport continues to incorporate innovations such as solar, electric charging, and robotics in their operations. The airport's sustainability goal is to become Net Zero Carbon by 2050.

Amazon and DHL also have over-the-road operations and other distribution warehouses across the region. DHL augments their air shipping capacity using over the road trips to airports in the Chicago and New York areas. Amazon is included in the ARCH2 H2Hub proposal with the intent to include hydrogen powered forklifts at sites in Ohio.

Other notable companies in the region include Ford, with one manufacturing plant, and Kroger, with many production and distribution centers. Beyond the immediate area, Millennium Reign Energy in Dayton designs, manufactures, and distributes hydrogen fueling stations.

The Metropolitan Planning Organization (MPO) representing Northern Kentucky – the OKI Regional Council of Governments (OKI) has successfully completed a competitive process to award Carbon Reduction Program (CRP) funds for electric vehicle chargers in the region. This planning agency could be a partner for developing hydrogen fueling infrastructure.

LEXINGTON

Recognizable brands such as Amazon and DHL have distribution centers in Central Kentucky. South of Lexington, PPL (LG&E and KU) with the University of Kentucky, is researching green hydrogen production. North of Lexington, in Georgetown, Toyota assembles Camrys as well as heavy-duty truck hydrogen fuel cells. The MPO in Lexington has also begun exploring the potential for hydrogen as a fuel.

LOUISVILLE

The Louisville airport serves as the air freight hub for UPS. Many companies have located near the airport to take advantage of the global reach of fast delivery speeds. UPS began testing a standard delivery truck that operates on hydrogen fuel cells in 2017, followed a few years later with a test of tractor trailers using Toyota Fuel Cells also in California. For their last mile - box truck, compressed natural gas vehicles currently operate throughout the city of Louisville.

Ford builds trucks, SUVs, and heavy-duty vehicles at two assembly plants in Louisville. The company has signaled their fuel transition will be with battery electric. Ford is building a battery plant south of Louisville, on the I-65 corridor. The company has experience with other sources of fuel including ethanol and compressed natural gas pickup trucks. The company recently began testing a hydrogen fuel cell version of their standard delivery van (Europe).

In addition to Louisville's position in Ford's supply chain (primarily I-65), the city sits between several components of Toyota's manufacturing network (I-64). Others, including Kroger, Walmart, and Amazon operate large facilities in and around the region.

The University of Louisville (U of L) is building a network of potential partners in a hydrogen fuel project that includes Clariant, GE Appliances (Haier), the TARC and others through REBECCA. UofL was unsuccessful in a bid for a hydrogen fueling station that included a transit bus that would operate in areas of the city with air quality and environmental justice concerns.

Concepts and Site Locations

Two operational scenarios were examined to assess the requirements, feasibility, and cost of implementing medium- and/or heavy-duty hydrogen powered truck operations in Kentucky.

Scenario 1: Long-Distance Point-to-Point Freight Operations - The first scenario examined long-distance freight operations serving major manufacturing facilities. This arrangement would connect manufacturing facilities (and possibly suppliers) along a major manufacturing corridor.

Scenario 2: Centralized Hub and Spoke Freight Operations – The second scenario explored a regional hub-and-spoke operation. In this situation, all vehicles would depart from, and return to, the same facility each day.

For each scenario, three conceptual levels of station investment were considered:

4. **Pilot Scale** – Small temporary station
5. **Liquid Delivery** - Permanent station receiving liquid delivery
6. **On-site Generation** - Permanent station with on-site hydrogen production

Scenario 1: Long-Distance Point-to-Point Freight Operations

There are many vehicle manufacturing facilities in Kentucky including major facilities in Georgetown, Louisville, and Bowling Green. New EV battery plants are also being added along I-65. This “auto alley” extends south through Tennessee into Alabama. Therefore, a corridor running from near Georgetown, KY west to Louisville and then south to near Huntsville in Alabama was selected as a test case for long-distance hydrogen powered truck operations (See **Figure 22**).

Vehicle Specifications

The Hyzon HYHD8-200 truck was selected as the representative heavy-duty FCEV. The HYHD8-200 has the capacity to store 50 kg of hydrogen in tanks mounted behind the cab. Batteries and power train equipment occupy the engine compartment and base of the vehicle. The nominal range for this vehicle, according to company sources, is 350-miles. However, the company recommends refueling before reaching the maximum range as actual driving conditions (e.g., weather, traffic congestion, and topography) may impact the distance traveled on a single fill-up. For this feasibility assessment, the assumed typical range was set at less than 300 miles.

Route Considered

The one-way distance from near Georgetown, KY to near Huntsville, AL is 345 miles via I-64, and I-65 (**Figure 22**). This distance exceeds the practical range of the representative Hyzon truck. To maintain reliable truck operations on this route, hydrogen fueling stations would be required at either end and at one intermediate location. Bowling Green, KY is located near the halfway point. With a station located in this city, the longest distance between stations would be approximately 176 miles between Georgetown and Bowling Green.



Source: HDR

Figure 22: Route between Georgetown and Huntsville

Fuel Requirements

The amount of fuel required to have on hand in the three-station network is dependent upon the number of trucks served per day. Fuel consumption is based on a one-way trip with a fuel efficiency of seven kilograms per mile, which equates to 49.3 kilograms of hydrogen per one-way trip. A round trip of 690 miles would require 98.6 kilograms of hydrogen fuel. This information was used in the next section to examine the three concepts for operating the fueling stations.

Scenario 2: Centralized Hub and Spoke Freight Operations

A second scenario was evaluated to consider the feasibility of using hydrogen for local freight distribution. This was developed to consider use cases with a hub and spoke configuration such as last mile freight delivery. In this scenario, trucks run routes in a specific geographical area and always return to the point of origin for refueling. These types of routes would typically involve multiple stops throughout the route and movement within an urban environment.

Vehicle Specifications

This type of delivery operation typically involves using medium- to light-duty vehicles, which are better suited to the stop and go nature of these routes and the potentially congested urban environment. A medium-duty FCEV delivery truck produced by Quantron was selected as the representative vehicle (**Figure 23**). Quantron advertises an ideal range of up to 280 miles with an 8.2 kg tank. To be conservative and ensure all trucks would be able to return to the point of origin on one tank, a maximum range of 200 miles was assumed.



Source: Quantron

Figure 23: Medium-Duty FCEV Truck

Route Considered

The route that can be driven in a hub-and-spoke scenario is directly related to the range of the vehicle. Since all vehicles will be required to return to the point of origin to refuel, the route must be planned such that sufficient fuel remains to allow the vehicle to return.

Often these types of routes are planned in a circular fashion such that multiple deliveries can be made throughout a region both as the vehicle travels away from the refueling facility and as the vehicle returns to the refueling facility. With the conservative maximum range of 200 miles, it was assumed that these vehicles would operate with a maximum radius of 100 miles in any direction from the central refueling station (**Figure 24**).

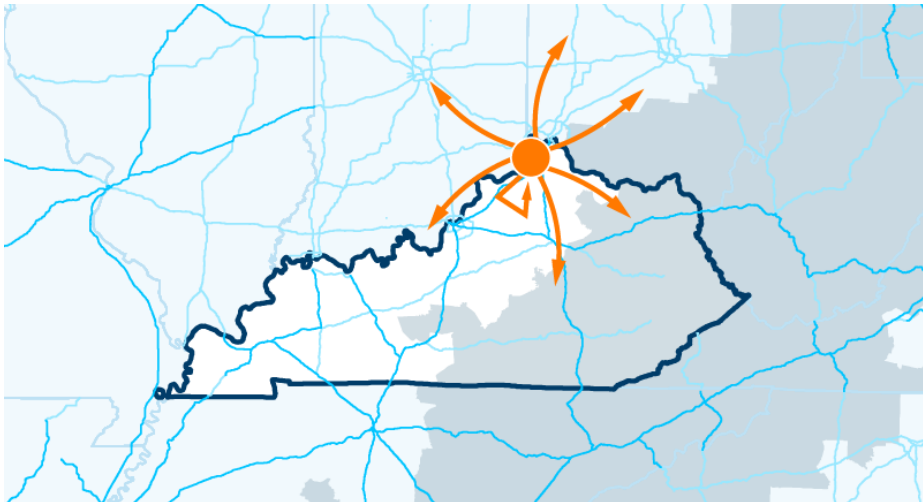

Source: HDR

Figure 24: Hub-and-Spoke Scenario (100-mile range)

Fuel Requirements

The amount of fuel required for this configuration is dependent on the number of trucks that run a given route, the total number of shifts that each truck runs in a day, and the fuel economy that can be achieved by these trucks over the course of a shift. These values assume each truck runs two 200-mile shifts per day and that an average fuel economy of 24 mile/kg is achieved during operation. This information was used in the next section to examine the expected daily hydrogen needs for various levels of truck deployment.

Station Concepts

The three hydrogen refueling station concepts, Pilot Scale, Liquid Delivery, and On-site Generation were examined to assess how they would perform for the two operational scenarios. HDR's proprietary Hydrogen Development Toolkit was used to aid in this evaluation. The goal of the analysis was to determine what level of functionality could be obtained with each concept (could they meet the fueling requirements) and to assess the capital cost ranges. **Table 3** shows the operational data and required fuel deliveries for Scenario 1 and **Table 4** shows the same information for Scenario 2.

Table 3: Long-Distance Point-to-Point Freight Operations

		Truck Trips Per Day >					
		1	5	10	20	30	40
Scenario 1 Operational Data	Vehicle Miles Traveled	690	3,450	6,900	13,800	20,700	27,600
	Hydrogen Consumed (kg)	99	493	986	1,971	2,957	3,943
	Hydrogen Used Per Station (kg)	33	164	329	657	986	1,314
Pilot Scale	Gas Delivery Every X Days	9	2	1	NA	NA	NA
Liquid Delivery	Liquid Delivery Every X Days	126	25	13	6	4	3
On-Site Generation	% of Daily Capacity Used (1,000kg)	3%	16%	33%	66%	99%	131%

Assumptions

One-Way Trip Length (miles)	345
Round Trip Length (miles)	690
Miles per kg of Hydrogen	7
Round Trips per Day	1
Stations	3
Gaseous Delivery Capacity (kg)	300
Liquid Delivery Capacity (kg)	4000
On-Site Generation Capacity (kg/day)	1000

Table 4: Regional Hub and Spoke Operations

		Truck Trips Per Day >					
		5	10	25	50	100	150
Scenario 2 Operational Data	Vehicle Miles Traveled	2,000	4,000	10,000	20,000	40,000	60,000
	Hydrogen Consumed (kg)	83	167	417	833	1,667	2,500
	Hydrogen Used Per Station (kg)	83	167	417	833	1,667	2,500
Pilot Scale	Gas Delivery Every X Days	4	2	0.7	NA	NA	NA
Liquid Delivery	Liquid Delivery Every X Days	48	24	10	5	2.4	1.6
On-Site Generation	% of Daily Capacity Used (1,000kg)	8%	17%	42%	83%	167%	250%

Assumptions

One Round Trip Length (miles)	200
Miles per kg of Hydrogen	24
Round Trips per Day	2
Stations	1
Gaseous Delivery Capacity (kg)	300
Liquid Delivery Capacity (kg)	4000
On-Site Generation Capacity (kg/day)	1000

The technical details for the three concepts are presented in **Table 5**. These details relate to the concept diagrams presented later in the document. They were the starting point for the order-of-magnitude cost estimates that were prepared as well.

Table 5: Comparison of Hydrogen Fueling Concepts (Initial Assumptions)

	Pilot Scale	Liquid Delivery	On-site Generation
Footprint	> 30ft x 65ft	> 70ft x 90ft <i>Concept Number 1 with a vaporizer (Figure 28)</i>	> 80ft x 160ft <i>Concept Number 2 with building to house production (Figure 30)</i>
Electrolyzer			2-qty 83 kg/hr or 1000 kg/day >4,100 kW
Liquifier			1-qty >1,000 kW
LH2 Deliveries		Base Assumption: 3.5 deliveries/week 83 units per delivery	
GSH2 Deliveries	Base Assumption: 2.22 deliveries/week 4 units per delivery		
Hydrogen Storage	Gaseous 1-qty 660-1,100 kg	Liquid 1-qty > 6,000 kg @ 0 psig -423 deg F	Liquid 1-qty > 6,000 kg @ 0 psig -423 deg F
Pump		1-qty 400 kg/hr	1-qty 400 kg/hr
Vaporizer		1-qty 400 kg/hr @ 3,000 psig 60 deg F	1-qty 400 kg/hr @ 3,000 psig 60 deg F
Station Module with Gaseous Storage	1-qty 85 kg @ 7,300 psig 103 deg F 40 kW	2-qty 1,800 kg @ 7,300 psig 212 deg F >360 kW	2-qty 1,800 kg @ 7,300 psig 212 deg F >360 kW
Hydrogen Dispenser	1-qty	2-qty	2-qty

Pilot Scale

The minimum investment in hydrogen fueling infrastructure to initiate freight service includes positioning a portable gas storage trailer (1,000 kg capacity) and a portable fueling trailer on site or setting up stationary versions of those two elements (i.e., hydrogen storage tanks and a fuel dispenser), see **Figure 25** and **Figure 26**. The fuel would be replenished by a vendor. The gaseous tube trailers that would resupply the site typically carry approximately 300 kg of hydrogen.

SCENARIO 1 LONG DISTANCE

A pilot scale approach to serving the long-distance point-to-point operation would require three stations. Deliveries of high-pressure gaseous hydrogen would need to be made to each location. **Table 3** shows the number of deliveries each day for different activity levels. Five trucks would require a delivery about once every two days to each station. That is the maximum number of trucks that could reasonably be served using this approach.

Increasing the number of trucks and deliveries could create traffic backups, which could negatively impact operations. Substantial new investment would be needed to construct a permanent facility. None of the pilot scale equipment would be usable to support that upgrade.

This pilot scale set-up would likely cost \$3 to \$7 million per station for the equipment and installation. This would result in a \$8 to \$20 million project, depending on how many trucks per day it is designed to serve and the permanence of the installation. This is a substantial investment for a modest truck operation.

SCENARIO 2 REGIONAL HUB AND SPOKE

A pilot scale approach to serving the regional hub and spoke operation would require one pilot refueling station. Given the hydrogen use per station per day (**Table 4**), this operation would require deliveries every three to four days for five trucks. It would require a delivery about once every two days for 10 trucks. That is potentially the maximum number of trucks that could reasonably be served using this approach.

Increasing the number of trucks and deliveries could create traffic backups, which could negatively impact operations. None of the pilot scale equipment would be usable to support upgrading to a permanent facility.

This pilot scale set-up could cost \$3 to \$7 million for the equipment and installation, depending on how many trucks per day it is designed to serve and the permanence of the installation. It is assumed based on industry data that a full ten truck per day system could cost up to \$10 million.

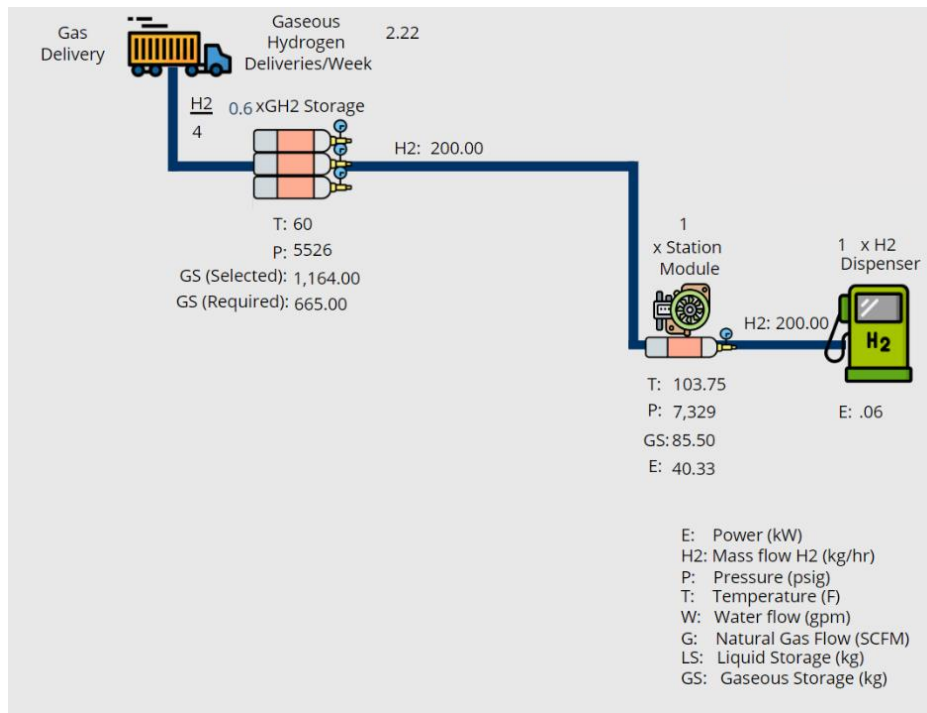

Figure 25: Flow Diagram for Equipment Required for Gaseous Delivery Concept

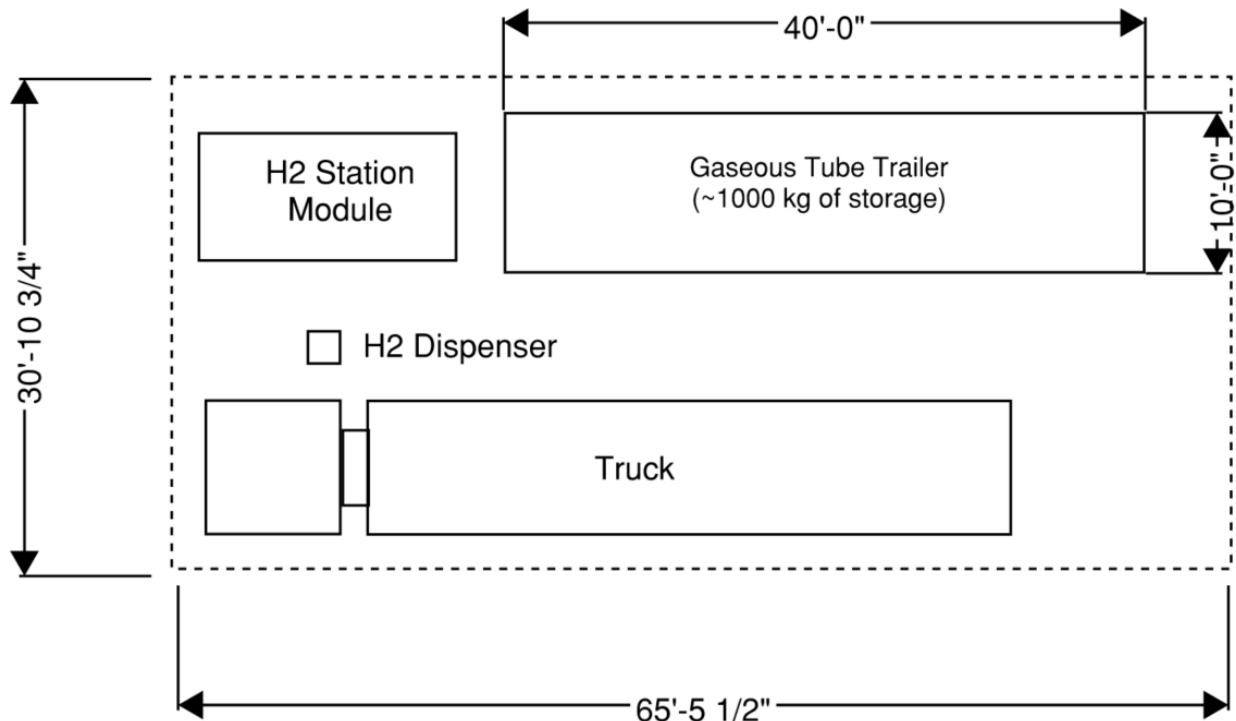

Figure 26: Site Layout for Gaseous Delivery Concept

Liquid Delivery

A longer-term investment in hydrogen fueling infrastructure would involve installing liquid hydrogen storage tanks and two fuel dispensers (**Figure 27** and **Figure 28**). Storage of liquid hydrogen requires specialized cryogenic equipment capable of maintaining the liquified gas at -423°F. Because FCEVs operate on pressured gaseous hydrogen, a vaporizer would be required to convert the liquid to a gas for dispensing into the truck. The advantages of liquid hydrogen delivery over gaseous hydrogen include the volume of the fuel that can be transported over long distances. Typical liquid hydrogen trucks can transport up to 4,000 kg of liquid hydrogen.

SCENARIO 1 LONG DISTANCE

A liquid delivery approach to serving the long-distance point-to-point operation would require three stations with regular liquid deliveries to each location. **Table 3** shows the number of deliveries each day for different activity levels. A system such as this could accommodate up to 20 trucks/day with deliveries of liquid hydrogen arriving by truck every six days to each station. The option presented here could be scaled up to serve a larger number of trucks with larger equipment and more frequent deliveries. However, as with gaseous hydrogen delivery, a limiting factor is the ability of the site to receive fuel delivery as the fuel use increases. The cost of the equipment and installation for a single station could be \$8 to \$15 million. However, for a three-station installation, it is expected that there would be economies of scale and the equipment could be right-sized at each location. The order of magnitude cost estimate for this project is expected to be in the \$20 to \$40 million range.

SCENARIO 2 REGIONAL HUB AND SPOKE

A liquid delivery approach to serving the regional hub and spoke operation would require only one refueling station. Given the hydrogen use per station per day (**Table 4**), this operation would require deliveries every five days for 50 trucks. Again, it could be scaled up with more deliveries and potentially additional or larger equipment. Increasing the number of trucks and deliveries could create traffic backups, which would need to be mitigated by expanding the site size and adding equipment.

This approach is predicted to have an order of magnitude cost of \$8 to \$15 million for equipment and installation. The cost will depend in part of the final decisions regarding the scale of the equipment and installation, such as the final tank sizes.

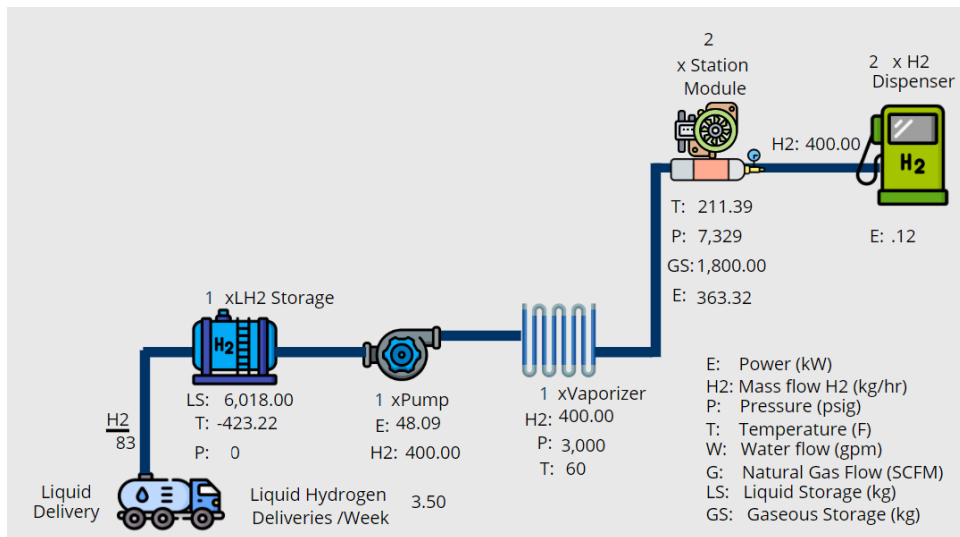

Figure 27: Flow Diagram for Equipment Required for Liquid Delivery Concept

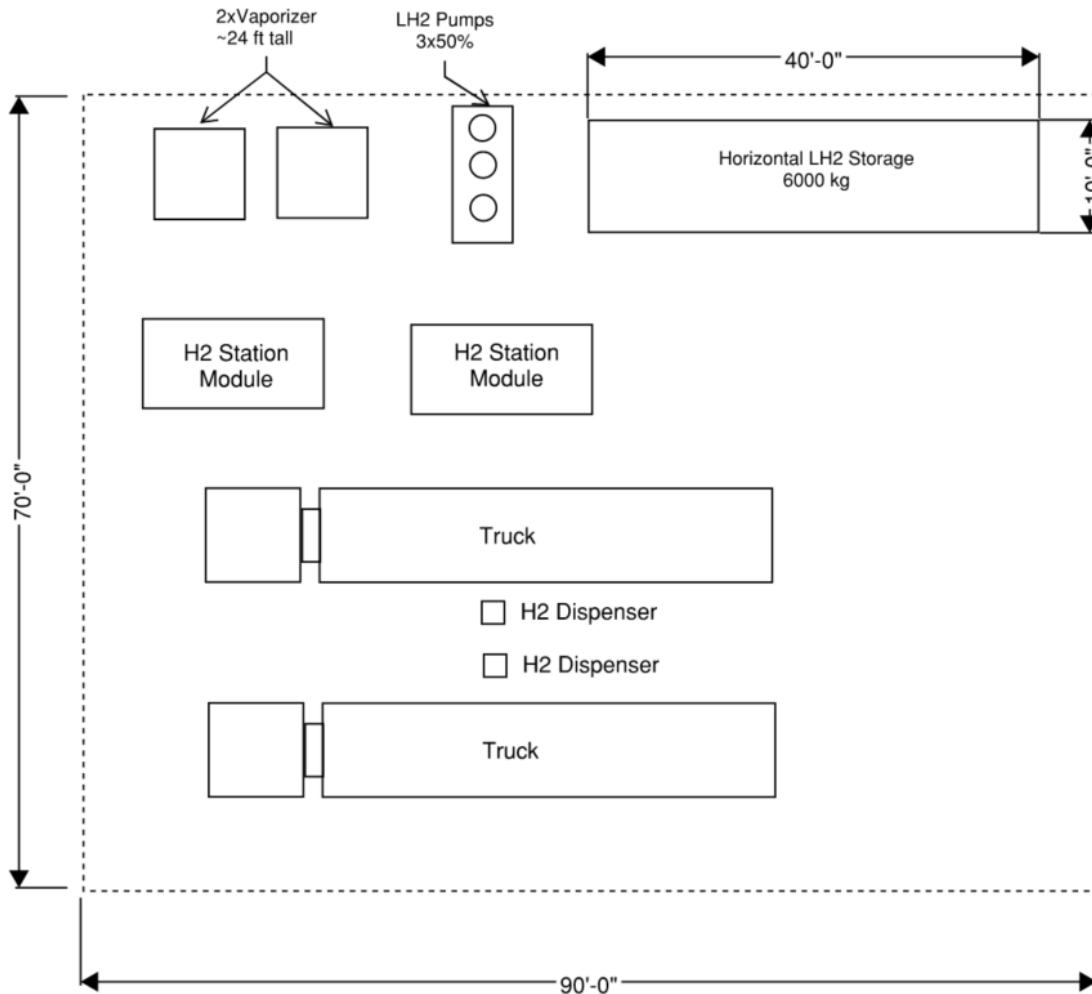

Figure 28: Site Layout for Liquid Delivery Concept

On-site Generation

As a point of reference, on-site generation is included in this high-level examination of hydrogen fuel infrastructure. The level of detail and the number of options possible for on-site generation complicate comparisons to the delivery options for hydrogen fuel. On-site generation is a significant investment in the technology. In this example, hydrogen is generated through electrolysis, which would require frequent maintenance. Once generated, the fuel would then be stored as a liquid. More energy can be stored as liquid hydrogen than the same volume of hydrogen gas. However, before fueling the vehicle, liquid hydrogen regasification is required. **See Figures 29 and 30.**

SCENARIO 1 LONG DISTANCE

Three stations with on-site hydrogen generation of 1,000 kg per day could have the capacity to serve 20 to 30 trucks per day (**Table 3**) for the long-distance scenario. Electrolyzers generate a fixed amount of hydrogen per unit of time depending on their size. This technology is not scalable. Replacement would be required to increase production. The order of magnitude cost for a single station using this approach could be \$30 to \$50 million including equipment and installation. Therefore, for a three-station system, the order of magnitude capital costs could reach or even exceed \$100 million.

SCENARIO 2 REGIONAL HUB AND SPOKE

A single-station hub-and-spoke operation with on-site hydrogen generation of 1,000 kg per day could have the capacity to serve 50 trucks per day (**Table 4**). Electrolyzers generate a fixed amount of hydrogen per unit of time depending on their size. This technology is not scalable. Replacement would be required to increase production. The order of magnitude cost for a single station using this approach could be as high as \$50 million.

Cost Summary

Capital Costs - The order-of-magnitude cost estimates for the two scenarios and three concepts range from \$3 million to over \$100 million (**Table 6**). This is directly related to the number of stations and the technological approach to supplying the hydrogen. It should be noted that these are very high-level estimates based on generalized industry data.

Table 6: Order of Magnitude Capital Cost Estimates

Concepts	Scenario 1 Long-Distance Point-to-Point Three Stations	Scenario 2 Centralized Hub and Spoke One Station
Pilot Scale	\$8 - \$20 million	\$3 - \$7 million
Liquid Delivery	\$20 – \$40 million	\$8 – \$15 million
On-site Generation	~\$100 million	~\$50 million

Operations and Maintenance Costs - It is estimated that operations and maintenance costs could be 2.5% annually based on the capital costs. For a \$10 million facility that would be \$250,000 per year.

Fuel Costs - Fuel costs at present, range from approximately \$9 to \$12/kg for grey hydrogen. For the long-distance scenario with 20 trucks, this would result in an annual fuel cost of \$5.3 million to \$7.1 million assuming 300 working days. For the hub and spoke operation, the fuel cost could be \$2.3 million to \$3.0 million for a 50-truck operation, assuming 300 operating days.

Vehicle Costs - The cost of a hydrogen long-distance truck is expected to be \$750,000 in the near term, though this is predicted to decrease as production ramps up.

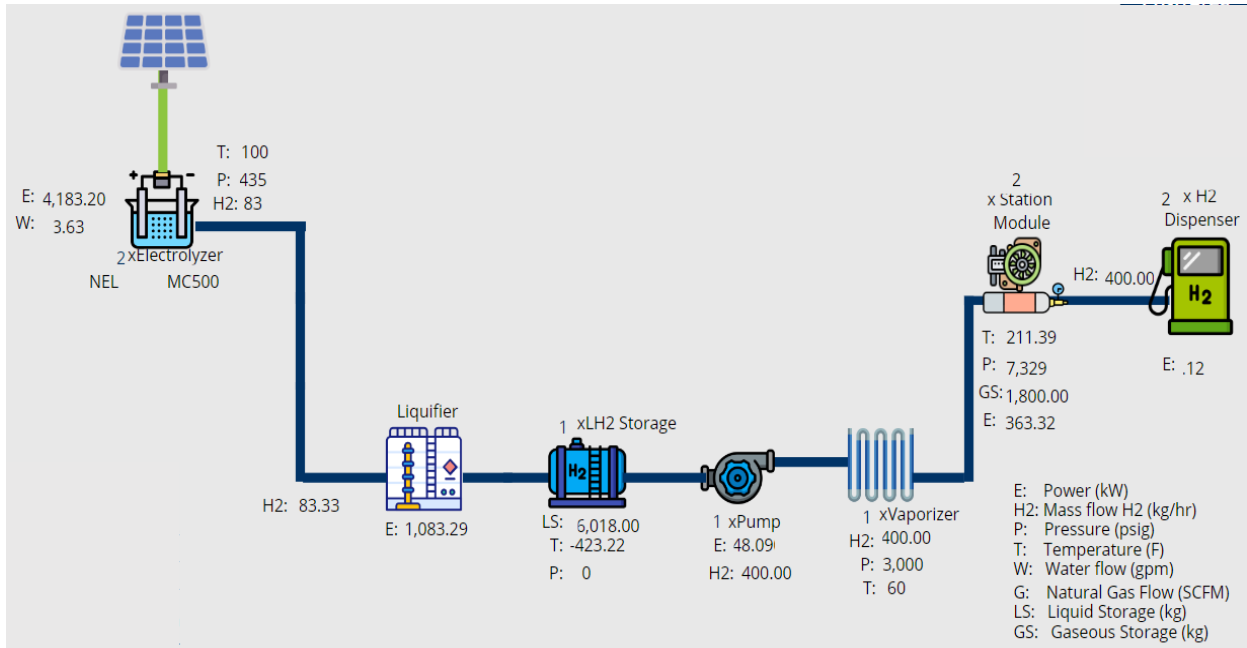

Figure 29: Flow Diagram for Equipment Required for On-Site Generation Concept

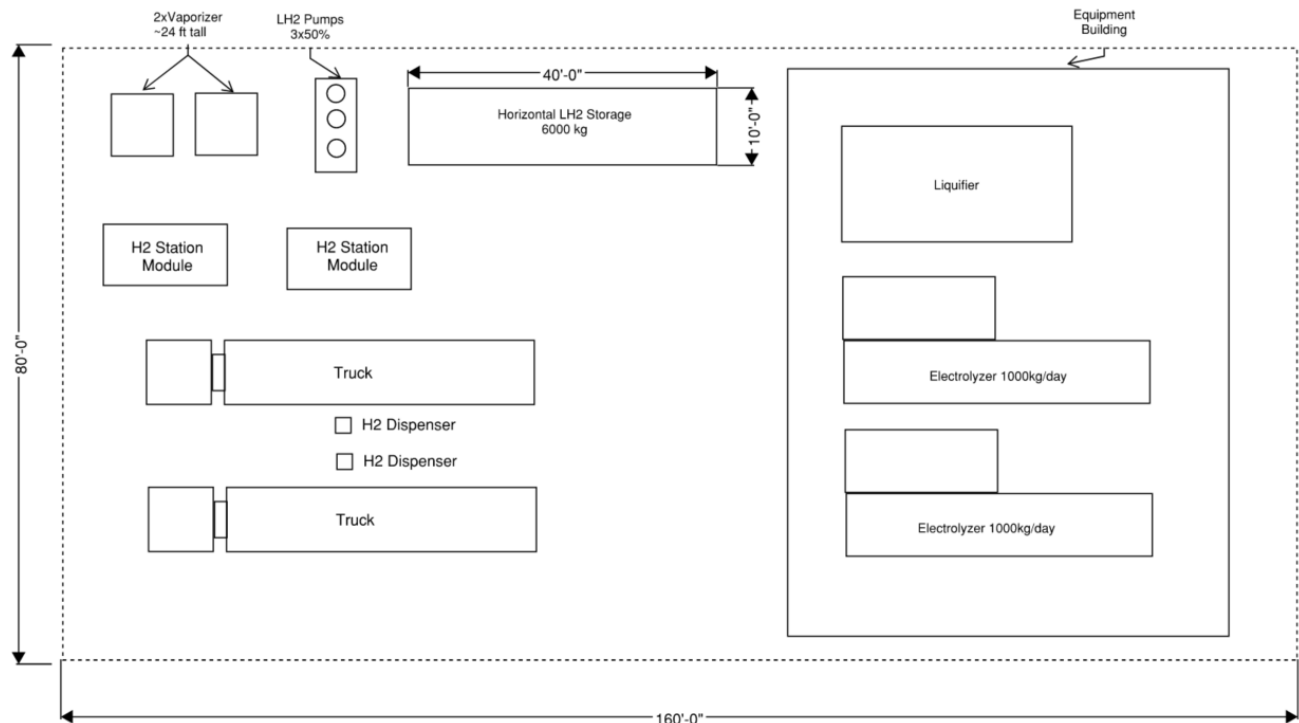

Figure 30: Site Layout for On-Site Generation Concept

Feasibility Assessment Findings

This feasibility analysis has highlighted several important opportunities and constraints with regards to implementing hydrogen powered freight movement in the state. There are actions the state can take to make the most of the opportunities and to mitigate the constraints. An action plan is provided in **Table 7** to help outline a possible path forward.

Opportunities

The major opportunities for hydrogen-powered truck refueling fall into two categories: National and Kentucky specific.

National / Industry-wide Opportunities

- Hydrogen Hubs (Supply Side) and Hydrogen Demand Subsidies (Demand Side)
- Federal funding opportunities for infrastructure
 - Charging and Fueling Infrastructure Grants
 - Other funding opportunities from USDOE and USDOT

Kentucky Opportunities

- Several large shipping and manufacturing companies that have made commitments to be carbon neutral by 2050 and have dedicated significant resources to accomplish that goal
- Proximity to the ARCH2 hydrogen hub and ability to pursue hydrogen from that source
- Interest by public agency partners in pursuing hydrogen for transportation
- Private and university research into green hydrogen production

Constraints

The major constraints include several that are industry-wide level constraints and some that are Kentucky specific constraints.

National / Industry-wide Constraints

- High price of hydrogen fuel
- High cost of hydrogen-powered trucks and refueling infrastructure
- Lack of green hydrogen supply

Kentucky Constraints

- Lack of state funding for hydrogen powered truck refueling infrastructure
- Lack of state policy initiatives for hydrogen powered truck refueling infrastructure

Scenarios and Concepts

The assessment of Kentucky's place in the nascent hydrogen fuel economy leaves two primary options for the state to explore:

- A. A single public refueling station built as a hub for regional operations. This could be in Northern Kentucky, Louisville, or Lexington and could serve to support some combination of shipping company operations (e.g., Amazon, DHL, UPS), major manufacturing operations (e.g., Toyota or Ford), and/or transit operators (e.g., TARC, TANK, or Lextran).

- B. A multi-station long-distance refueling operation. This option would likely involve freight shipping for one or more major manufacturing companies (e.g., Toyota, Ford, or GM), though other long-distance delivery companies may be interested in being part of it.

Large corporations with research capabilities and considerable financial resources are likely to be the earliest adopters who may be interested in a hydrogen-powered truck partnership. These could include car manufacturers, package handling companies, large discount stores or grocery stores, and freight shippers. Some large trucking companies such as JB Hunt, have introduced electric and hydrogen trucks into their fleets based in California and Arizona. These companies could also be early adopters as they are familiar with the technology and have emission reduction goals.

CFI Grant Opportunity

The next CFI grant program Notice of Funding Opportunity (NOFO) is expected to be announced in Summer 2024 and likely, again a year later. This program may be one of the best avenues for securing 80% federal support for refueling stations. It will be necessary to secure private or non-state public partners to help provide the required 20% non-federal match.

Texas offers a model for Kentucky to pursue to line up plans, policies, and partners to introduce hydrogen refueling stations to the Commonwealth (**Figure 31**).

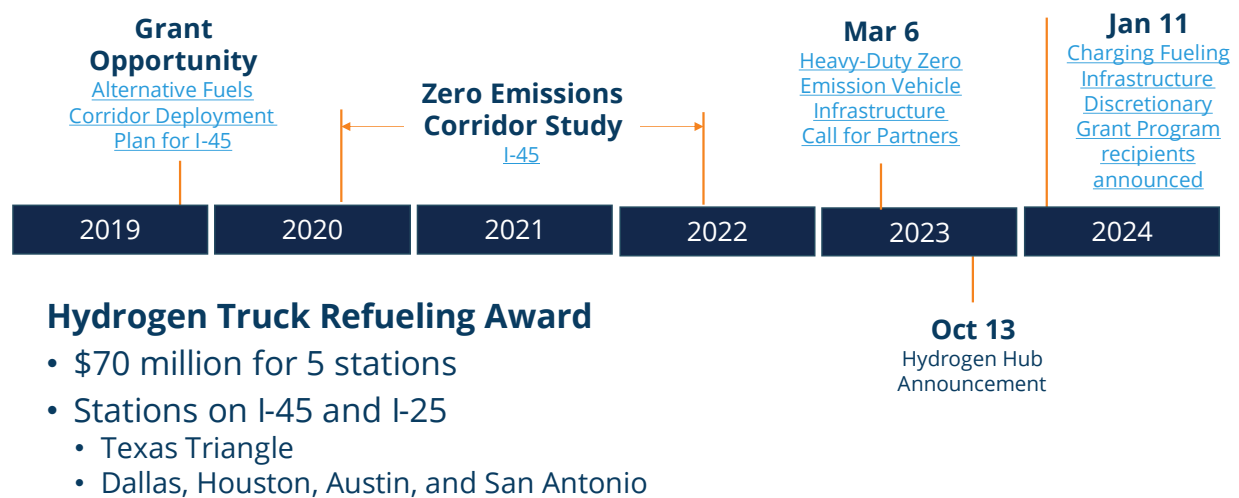

Figure 31: Texas Hydrogen Truck Fueling Initiative

In 2023, the [North Central Texas Council of Governments Metropolitan Planning Organization \(NCTCOG\)](#) released a call for partners to deploy publicly accessible fueling infrastructure for medium- and heavy-duty vehicles. The MPO represents the Dallas-Fort Worth region. The agency was able to pull private firms and other interested agencies together to access federal funding opportunities. The call for partners followed efforts by the local Clean Cities chapter and coordination with counterparts in Houston to explore how to reduce emissions in the I-45 corridor. The *Interstate Highway 45 Corridor Zero Emission Vehicle Plan* (2022) evaluated traffic and freight flows between these cities, ports, and the nation. The study examined adoption of zero emission vehicles, access to the hydrogen produced in the state, and infrastructure funding scenarios.

Later that year, the partners developed a CFI Grant application that included infrastructure for hydrogen and electric vehicles. The application was awarded \$70 million to build five hydrogen fueling stations in the Texas Triangle (Dallas, Houston, Austin, and San Antonio).

Action Plan

The action plan outlined in **Table 7** offers actionable steps that could be taken to advance hydrogen powered truck fueling in the state. The agencies listed as responsible for different actions could change over time, but this initial list proposes entities that could implement these actions.

Table 7: Action Plan

Timeline	Recommended Action	Responsible Agencies
Continuous	Build awareness about hydrogen in the transportation sector	EEC, KYTC, MPOs, Workgroup
	Build hydrogen and transportation industry partnerships	EEC, KYTC, MPOs, Workgroup
	Identify funding for hydrogen research, development, and infrastructure	EEC, Universities, MPOs, Workgroup
Short (1-2 years)	Coordinate with public agencies to develop a request for partners establishing hydrogen fueling stations in the State	EEC, KYTC, MPOs
	Research emerging examples of truck hydrogen refueling	EEC, Universities, Workgroup
Medium (2-5 years)	Apply for CFI Grant for hydrogen fueling stations	TBD
	Formalize off-take agreements with Arch2 and MachH2	TBD
	Incubate green technology and hydrogen production in Kentucky	EEC, Universities
Long (5-10 years)	Develop hydrogen infrastructure standards	EEC, KYTC
	Build-out hydrogen AFCs	EEC, KYTC, MPOs
	Identify and implement industry partnerships for future high-volume hydrogen production	TBD