



October 27, 2025

Department of Environmental Protection
Division of Air Quality
300 Sower Blvd, 2nd Floor
Frankfort, KY 40601

Re: Amrize Building Envelope, LLC
Source ID: 21-117-00177

Dear Permit Reviewer,

DECA Environmental & Associates, Inc. (DECA), on behalf of Amrize Building Envelope, LLC (Amrize), is submitting the enclosed air permit renewal application for review and processing. The Amrize facility is located at 8170 Holton Drive, Florence, Kentucky 41042.

As part of this renewal submission, Amrize respectfully requests the removal of the current total capture efficiency testing requirement associated with the Laminator Enclosure and Chemical Pump Enclosure (Emission Unit EU-002). The enclosed technical support letter provides the justification for this revision.

EPA guidance recognizes capture efficiency as a design-dependent parameter. Verification testing is only necessary following a significant physical or operational modification that could impact the capture system's performance. Since no modifications have occurred at the facility since issuance of the existing permit, Amrize proposes that the permit condition be revised so that capture efficiency testing is required only if a future equipment or process change has the potential to affect capture efficiency.

Provided with this letter are the DEP7007 AI, DEP7007N Forms and a Regulatory Review Summary for the removal of the capture efficiency testing of the RTO-2.

Once the permit reviewer is assigned, please contact Jim Euler at (317) 575-0095 or jeuler@decaenvironmental.com to discuss the application.

Sincerely,

A handwritten signature in black ink that reads "Jim B. Euler". The signature is written in a cursive style with a large, stylized "J" and "E".

Jim B. Euler

President | [DECA Environmental & Associates, Inc.](http://decaenvironmental.com)
410 1st Ave. NE | Carmel, IN 46032
Office: (317) 575-0095 | Cell: (317) 919-0491

Enclosures

DECA Environmental & Associates, Inc.

410 1st Ave. NE • Carmel, IN 46032 • (317) 575-0095 • Fax (317) 575-0096 • E-mail deca@indy.net

Attachment 1

Request to Remove Capture Efficiency Retesting Requirement

To: Kentucky Department for Environmental Protection
Division for Air Quality

From: Jim Euler
DECA Environmental (Environmental Consultant)
On behalf of Amrize Building Envelope LLC

Date: October 27, 2025

Subject: Air Permit Renewal – RTO-2 Capture Efficiency Retesting Requirement

Dear Division Permit Reviewer,

On behalf of Amrize Building Envelope LLC, this letter provides justification for the removal of the capture efficiency retesting requirement from the draft air permit renewal conditions associated with RTO-2 and the Laminator Enclosure and Chemical Pump Enclosure (Emission Unit EU-002).

Background:

RTO-2 serves as a control device for volatile organic compound (VOC) emissions from EU-002. The unit successfully completed initial performance testing on August 10, 2021, demonstrating compliance with both the capture efficiency and destruction efficiency requirements established under 401 KAR 50:055, Section 2(1)(a).

Since that time, the facility has not made any physical, mechanical, or operational modifications to the RTO, associated enclosures, or ductwork that could affect capture efficiency or control performance. The facility continues to maintain parametric monitoring (including combustion temperature and pressure differential) confirming continuous compliant operation.

Regulatory Basis:

401 KAR 50:055, Section 2(1)(a) requires initial performance testing within 180 days after initial start-up or achieving maximum production rate. As RTO-2 has been in continuous operation since its initial start-up and has not undergone reconstruction or modification (as defined in 401 KAR 51:001, Section 1(102)), the regulatory trigger for a new performance test has not been met.

Furthermore, 401 KAR 50:045, Section 1 authorizes the Division to require testing “as may be necessary to determine compliance.” However, this authority is discretionary and intended to ensure representativeness when process or control conditions have changed. In this case, the previous performance test results remain valid and representative of current operation.

EPA’s Guidelines for Determining Capture Efficiency (1995) similarly recognize that capture efficiency is a design-dependent parameter. Retesting is warranted only when the physical configuration or operating conditions of the capture system have been altered. No such changes have occurred at Amrize Building Envelope LLC.

Request:

Amrize respectfully requests that the following language be used in the permit renewal to replace the current capture efficiency retesting condition:

“Subsequent capture efficiency testing shall only be required if modifications occur that may reasonably be expected to alter the capture or destruction efficiency of RTO-2.”

This approach maintains the Division’s authority to require testing when warranted while avoiding redundant and unnecessary performance testing for unchanged systems.

Conclusion:

Given the absence of any equipment or operational changes since the 2021 approved test, the continued compliance of RTO-2 based on parametric monitoring, and the regulatory intent of 401 KAR 50:045 and 50:055, Amrize Building Envelope LLC requests that the capture efficiency retesting requirement be removed or modified as proposed above.

Please contact me at 317-575-0095 or jeuler@decaenvironmental.com if additional information or documentation is needed.

Respectfully submitted,

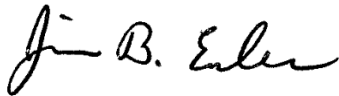

Jim Euler
DECA Environmental
On behalf of Amrize Building Envelope LLC

Division for Air Quality 300 Sower Boulevard Frankfort, KY 40601 (502) 564-3999	DEP7007AI Administrative Information ___ Section AL.1: Source Information ___ Section AL.2: Applicant Information ___ Section AL.3: Owner Information ___ Section AL.4: Type of Application ___ Section AL.5: Other Required Information ___ Section AL.6: Signature Block ___ Section AL.7: Notes, Comments, and Explanations	Additional Documentation ___ Additional Documentation attached
Source Name: <u>Amrize Building Envelope, LLC</u>		
KY EIS (AFS) #: <u>21- 117-00177</u>		
Permit #: <u>F-20-027 R2</u>		
Agency Interest (AI) ID: <u>71732</u>		
Date: _____		
Section AL.1: Source Information		
Physical Location	Street: <u>8170 Holton Dr.</u>	City: <u>Florence</u>
Address:	County: <u>Keton</u>	Zip Code: <u>41042-3010</u>
Mailing Address:	Street or P.O. Box: <u>8170 Holton Dr.</u>	State: <u>KY</u>
City: <u>Florence</u>	Zip Code: <u>41042-3010</u>	State: <u>KY</u>
Standard Coordinates for Source Physical Location		
Longitude: <u>38.970291</u> (decimal degrees)		
Latitude: <u>-84.609314</u> (decimal degrees)		
Primary (NAICS) Category: <u>Urethane and Other Fom Product Manufacturing</u>		
Primary NAICS #: <u>326150</u>		

Classification (SIC) Category:	<u>Foam Insulating Manufacturing</u>	Primary SIC #:	<u>3086</u>
Briefly discuss the type of business conducted at this site:			

Description of Area Surrounding Source:	<input type="checkbox"/> Rural Area	<input type="checkbox"/> Industrial Park	<input type="checkbox"/> Residential Area
Source:	<input type="checkbox"/> Urban Area	<input checked="" type="checkbox"/> Industrial Area	<input type="checkbox"/> Commercial Area
Is any part of the source located on federal land?	<input type="checkbox"/> Yes	Number of Employees: 48	
Is this source portable?	<input type="checkbox"/> Yes <input checked="" type="checkbox"/> No		
Approximate distance to nearest residence or commercial property: <u>acent business and residen</u>	Property Area: _____	Is this source portable? <input type="checkbox"/> Yes <input checked="" type="checkbox"/> No	
What other environmental permits or registrations does this source currently hold or need to obtain in Kentucky?			
NPDES/KPDES:	<input checked="" type="checkbox"/> Currently Hold	<input type="checkbox"/> Need	<input checked="" type="checkbox"/> N/A
Solid Waste:	<input type="checkbox"/> Currently Hold	<input type="checkbox"/> Need	<input checked="" type="checkbox"/> N/A
RCRA:	<input type="checkbox"/> Currently Hold	<input type="checkbox"/> Need	<input checked="" type="checkbox"/> N/A
UST:	<input type="checkbox"/> Currently Hold	<input type="checkbox"/> Need	<input checked="" type="checkbox"/> N/A
Type of Regulated Waste Activity:	<input type="checkbox"/> Mixed Waste Generator	<input type="checkbox"/> Generator	<input type="checkbox"/> Recycler
U.S. Importer of Hazardous Waste	<input type="checkbox"/> U.S. Importer of Hazardous Waste	<input type="checkbox"/> Transporter	<input type="checkbox"/> Treatment/Storage/Disposal Facility
Other: _____	<input checked="" type="checkbox"/> N/A		

Section AI.2: Applicant Information	
Applicant Name:	<u>Amrize Building Envelope, LLC</u>
Title: (if individual)	<u>Plant Manager</u>
Mailing Address:	Street or P.O. Box: <u>8170 Holton Dr.</u>
	City: <u>Florence</u> State: <u>KY</u> Zip Code: <u>41042</u>
Email: (if individual)	<u>jesse.megenhardt@amrize.com</u>
Phone:	<u>502-525-0774</u>
Technical Contact	
Name:	<u>Burton Joyner</u>
Title:	<u>Regional EHSS Manager</u>
Mailing Address:	Street or P.O. Box: <u>8170 Holton Dr.</u>
	City: <u>Florence</u> State: <u>KY</u> Zip Code: <u>41042</u>
Email:	<u>burton.joyner@amrize.com</u>
Phone:	<u>859-490-1564</u>
Air Permit Contact for Source	
Name:	<u>Burton Joyner</u>
Title:	<u>Regional EHSS Manager</u>
Mailing Address:	Street or P.O. Box: <u>8170 Holton Dr.</u>
	City: <u>Florence</u> State: <u>KY</u> Zip Code: <u>41042-3010</u>
Email:	<u>burton.joyner@amrize.com</u>
Phone:	<u>859-490-1564</u>

Section AI.3: Owner Information	
<input checked="" type="checkbox"/> Owner same as applicant	
Name:	_____
Title:	_____
Mailing Address:	Street or P.O. Box: _____
	City: _____ State: _____ Zip Code: _____
Email:	_____
Phone:	_____
List names of owners and officers of the company who have an interest in the company of 5% or more.	
Name	Position
_____	_____
_____	_____
_____	_____

Section AI.4: Type of Application			
Current Status:	<input type="checkbox"/> Title V	<input checked="" type="checkbox"/> Conditional Major	<input type="checkbox"/> State-Origin
	<input type="checkbox"/> Name Change	<input type="checkbox"/> Initial Registration	<input type="checkbox"/> Significant Revision
	<input checked="" type="checkbox"/> Renewal Permit	<input type="checkbox"/> Revised Registration	<input type="checkbox"/> Administrative Permit Amendment
Requested Action: <i>(check all that apply)</i>	<input type="checkbox"/> 502(b)(10)Change	<input type="checkbox"/> Extension Request	<input type="checkbox"/> Minor Revision
	<input type="checkbox"/> Revision	<input type="checkbox"/> Off Permit Change	<input type="checkbox"/> Addition of New Facility
	<input type="checkbox"/> Ownership Change	<input type="checkbox"/> Closure	<input type="checkbox"/> Landfill Alternate Compliance Submittal
			<input type="checkbox"/> Modification of Existing Facilities
Requested Status:	<input type="checkbox"/> Title V	<input checked="" type="checkbox"/> Conditional Major	<input type="checkbox"/> State-Origin
		<input type="checkbox"/> PSD	<input type="checkbox"/> NSR
			<input type="checkbox"/> Other: _____
Is the source requesting a limitation of potential emissions? <input type="checkbox"/> Yes <input checked="" type="checkbox"/> No			
Pollutant:	Requested Limit:	Pollutant:	Requested Limit:
<input type="checkbox"/> Particulate Matter	_____	<input type="checkbox"/> Single HAP	_____
<input type="checkbox"/> Volatile Organic Compounds (VOC)	_____	<input type="checkbox"/> Combined HAPs	_____
<input type="checkbox"/> Carbon Monoxide	_____	<input type="checkbox"/> Air Toxics (40 CFR 68, Subpart F)	_____
<input type="checkbox"/> Nitrogen Oxides	_____	<input type="checkbox"/> Carbon Dioxide	_____
<input type="checkbox"/> Sulfur Dioxide	_____	<input type="checkbox"/> Greenhouse Gases (GHG)	_____
<input type="checkbox"/> Lead	_____	<input type="checkbox"/> Other	_____
For New Construction:			
Proposed Start Date of Construction: <i>(MM/YYYY)</i>		Proposed Operation Start-Up Date: <i>(MM/YYYY)</i>	
_____		_____	
For Modifications:			
Proposed Start Date of Modification: <i>(MM/YYYY)</i>		Proposed Operation Start-Up Date: <i>(MM/YYYY)</i>	
_____		_____	
Identify any non-applicable requirements for which permit shield is sought on a separate attachment to the application.			
<input type="checkbox"/> Applicant is seeking coverage under a permit shield. <input type="checkbox"/> Yes <input checked="" type="checkbox"/> No			

Section AI.5 Other Required Information	
Indicate the documents attached as part of this application:	
<input type="checkbox"/> DEP7007A Indirect Heat Exchangers and Turbines <input type="checkbox"/> DEP7007B Manufacturing or Processing Operations <input type="checkbox"/> DEP7007C Incinerators and Waste Burners <input type="checkbox"/> DEP7007F Episode Standby Plan <input type="checkbox"/> DEP7007J Volatile Liquid Storage <input type="checkbox"/> DEP7007K Surface Coating or Printing Operations <input type="checkbox"/> DEP7007L Mineral Processes <input type="checkbox"/> DEP7007M Metal Cleaning Degreasers <input type="checkbox"/> DEP7007N Source Emissions Profile <input type="checkbox"/> DEP7007P Perchloroethylene Dry Cleaning Systems <input type="checkbox"/> DEP7007R Emission Offset Credit <input type="checkbox"/> DEP7007S Service Stations <input type="checkbox"/> DEP7007T Metal Plating and Surface Treatment Operations <input type="checkbox"/> DEP7007V Applicable Requirements and Compliance Activities <input type="checkbox"/> DEP7007Y Good Engineering Practice and Stack Height Determination <input type="checkbox"/> DEP7007AA Compliance Schedule for Non-complying Emission Units <input type="checkbox"/> DEP7007BB Certified Progress Report	<input type="checkbox"/> DEP7007CC Compliance Certification <input type="checkbox"/> DEP7007DD Insignificant Activities <input type="checkbox"/> DEP7007EE Internal Combustion Engines <input type="checkbox"/> DEP7007FF Secondary Aluminum Processing <input type="checkbox"/> DEP7007GG Control Equipment <input type="checkbox"/> DEP7007HH Haul Roads <input type="checkbox"/> Confidentiality Claim <input type="checkbox"/> Ownership Change Form <input type="checkbox"/> Secretary of State Certificate <input type="checkbox"/> Flowcharts or diagrams depicting process <input type="checkbox"/> Digital Line Graphs (DLG) files of buldings, roads, etc. <input type="checkbox"/> Site Map <input type="checkbox"/> Map or drawing depicting location of facility <input type="checkbox"/> Safety Data Sheet (SDS) <input type="checkbox"/> Emergency Response Plan <input type="checkbox"/> Other: _____

Section AI.6: Signature Block	
<p>I, the undersigned, hereby certify under penalty of law, that I am a responsible official*, and that I have personally examined, and am familiar with, the information submitted in this document and all its attachments. Based on my inquiry of those individuals with primary responsibility for obtaining the information, I certify that the information is on knowledge and belief, true, accurate, and complete. I am aware that there are significant penalties for submitting false or incomplete information, including the possibility of fine or imprisonment.</p>	
_____ Authorized Signature	_____ Date
_____ Jesse Megenhardt	_____ Plant Manager
_____ Type or Printed Name of Signatory	_____ Title of Signatory
*Responsible official as defined by 401 KAR 52:001.	

Section A1.4: Type of Application

Current Status: Title V Conditional Major State-Origin General Permit Registration None

Requested Action: Name Change Initial Registration Significant Revision Administrative Permit Amendment
 Renewal Permit Revised Registration Minor Revision Initial Source-wide Operating Permit
 503(b)(10) Change Extension Request Addition of New Facility Peritable Plant Relocation Notice
 Revision Off-Permit Change Landfill Alternate Compliance Submittal Modification of Existing Facilities
 Ownership Change Closure

Requested Status: Title V Conditional Major State-Origin PSD NSR Other: _____

Is the source requesting a limitation of potential emissions? Yes No

Pollutant:	Requested Limit:	Pollutant:	Requested Limit:
<input type="checkbox"/> Particulate Matter	_____	<input type="checkbox"/> Single HAP	_____
<input type="checkbox"/> Volatile Organic Compounds (VOC)	_____	<input type="checkbox"/> Combined HAPs	_____
<input type="checkbox"/> Carbon Monoxide	_____	<input type="checkbox"/> Air Toxics (40 CFR 68 Subpart F)	_____
<input type="checkbox"/> Nitrogen Oxides	_____	<input type="checkbox"/> Carbon Dioxide	_____
<input type="checkbox"/> Sulfur Dioxide	_____	<input type="checkbox"/> Greenhouse Gases (GHG)	_____
<input type="checkbox"/> Lead	_____	<input type="checkbox"/> Other	_____

For New Construction:
 Proposed Start Date of Construction: (MM/YY) _____ Proposed Operation Start-Up Date: (MM/YY) _____

For Modifications:
 Proposed Start Date of Modification: (MM/YY) _____ Proposed Operation Start-Up Date: (MM/YY) _____

Applicant is seeking coverage under a permit shield. Yes No Identify any non-applicable requirements for which permit shield is sought on a separate attachment to the application.

Section A1.5 Other Required Information

Indicate the documents attached as part of this application:

<input type="checkbox"/> DEP7007A Indirect Heat Exchangers and Turbines	<input type="checkbox"/> DEP7007C Compliance Certification
<input type="checkbox"/> DEP7007B Manufacturing or Processing Operations	<input type="checkbox"/> DEP7007D Insignificant Activities
<input type="checkbox"/> DEP7007C Incinerators and Waste Burners	<input type="checkbox"/> DEP7007E Internal Combustion Engines
<input type="checkbox"/> DEP7007F Episodic Standby Plan	<input type="checkbox"/> DEP7007F Internal Aluminum Processing
<input type="checkbox"/> DEP7007G Volatile Liquid Storage	<input type="checkbox"/> DEP7007G Central Equipment
<input type="checkbox"/> DEP7007K Surface Coating or Finishing Operations	<input type="checkbox"/> DEP7007H Haul Roads
<input type="checkbox"/> DEP7007L Mineral Processes	<input type="checkbox"/> Confidentiality Claim
<input type="checkbox"/> DEP7007M Metal Cleaning Degreasers	<input type="checkbox"/> Ownership Change Form
<input type="checkbox"/> DEP7007N Source Emissions Profile	<input type="checkbox"/> Secretary of State Certificate
<input type="checkbox"/> DEP7007P Perchloroethylene Dry-Cleaning Systems	<input type="checkbox"/> Flowcharts or diagrams depicting process
<input type="checkbox"/> DEP7007R Emission Offset Credit	<input type="checkbox"/> Digital Line Graphs (DLG) files of buildings, roads, etc.
<input type="checkbox"/> DEP7007S Service Stations	<input type="checkbox"/> Site Map
<input type="checkbox"/> DEP7007T Metal Plating and Surface Treatment Operations	<input type="checkbox"/> Map or drawing depicting location of facility
<input type="checkbox"/> DEP7007V Applicable Requirements and Compliance Activities	<input type="checkbox"/> Safety Data Sheet (SDS)
<input type="checkbox"/> DEP7007Y Good Engineering Practice and Stack Height Determination	<input type="checkbox"/> Emergency Response Plan
<input type="checkbox"/> DEP7007AA Compliance Schedule for Non-complying Emission Units	<input type="checkbox"/> Other: _____
<input type="checkbox"/> DEP7007BB Certified Progress Report	

Section A1.6: Signature Block

I, the undersigned, hereby certify under penalty of law, that I am a responsible official* and that I have personally examined, and am familiar with, the information submitted in this document and all its attachments. Based on my inquiry of those individuals with primary responsibility for obtaining the information, I certify that the information is on knowledge and belief, true, accurate, and complete. I am aware that there are significant penalties for submitting false or incomplete information, including the possibility of fine or imprisonment.

Authorized Signature

Date
 10/27/25

Type or Printed Name of Signatory
 Jesse Meyerhand

Title of Signatory
 Plant Manager

*Responsible official as defined by 401 KAR 22.001.

Division for Air Quality 300 Sower Boulevard Frankfort, KY 40601 (502) 564-3999	DEP7007N Source Emissions Profile ___ Section N.1: Emission Summary ___ Section N.2: Stack Information ___ Section N.3: Fugitive Information ___ Section N.4: Notes, Comments, and Explanations	<table border="1" style="width: 100%; border-collapse: collapse;"> <tr> <td style="text-align: center;">Additional Documentation</td> </tr> <tr> <td style="text-align: center;">___ Complete DEP7007AI</td> </tr> </table>	Additional Documentation	___ Complete DEP7007AI
Additional Documentation				
___ Complete DEP7007AI				

Source Name: [Amrize Building Envelope, LLC](#)

KY EIS (AFS) #: 21- 117-00177

Permit #: [F-20-027 R2](#)

Agency Interest (AI) ID: [71732](#)

Date: [10/13/2025](#)

N.1: Emission Summary

Emission Unit #	Emission Unit Name	Process ID	Process Name	Control Device Name	Control Device ID	Stack ID	Maximum Design Capacity (SCC Units/hour)	Pollutant	Uncontrolled Emission Factor (lb/SCC Units)	Emission Factor Source (e.g. AP-42, Stack Test, Mass Balance)	Capture Efficiency (%)	Control Efficiency (%)	Hourly Emissions		Annual Emissions	
													Uncontrolled Potential (lb/hr)	Controlled Potential (lb/hr)	Uncontrolled Potential (tons/yr)	Controlled Potential (tons/yr)
1	Trim/Sawing Formboard			Dust Collector-Sawing				PM	See 2020 Calculations	See 2020 Calculations	99.50%	99.00%	163.38	1.63	715.59	7.16
1	Trim/Sawing Formboard							VOC	See 2020 Calculations	See 2020 Calculations					57.25	57.25
1	Trim/Sawing Formboard			Dust Collector-Sawing				PM	See 2020 Calculations	See 2020 Calculations	100%	99.00%	21.01	0.21	92.01	0.92
2	Foam Board Precessing Laminator			RTO				VOC	See 2020 Calculations	See 2020 Calculations	100%	96%			347.38	13.9
2	Foam Board Precessing Laminator			RTO				MDI	See 2020 Calculations	See 2020 Calculations	100%	96%			0.18	0.0072
2	Foam Board Precessing Laminator							Natural Gas Combustion in RTO	Natural Gas Combustion in RTO							
2	Foam Board Precessing Laminator							PM10	7.6 lb/10exp6 scf	AP-42			0.02	0.02	0.08	0.08
2	Foam Board Precessing Laminator							PM2.5	7.6 lb/10exp6 scf	AP-42			0.02	0.02	0.08	0.08
2	Foam Board Precessing Laminator							NOx	100 lb/10exp6 scf	AP-42			0.24	0.24	1.03	1.03
2	Foam Board Precessing Laminator							Natural Gas Combustion in RTO	Natural Gas Combustion in RTO							
2	Foam Board Precessing Laminator							CO	84 lb/10exp5 scf	AP-42			0.2	0.2	0.87	0.87
2	Foam Board Precessing Laminator							SO2	0.6 lb/10exp5 scf	AP-42			1.41E-03	1.41E-03	0.006	0.006
2	Foam Board Precessing Laminator							VOC	5.5 lb/10exp5 scf	AP-42			0.01	0.01	0.06	0.06
FUG 02	Foam Board Precessing Fugitive Laydown							VOC	See 2020 Calculations	See 2020 Calculations					14.47	14.47
FUG 02	Foam Board Precessing Fugitive Laydown							MDI	See 2020 Calculations	See 2020 Calculations					0.0075	0.0075
FUG 04	Warehouse - Fugitive							VOC	See 2020 Calculations	See 2020 Calculations					36.68	36.68

Section N.2: Stack Information

UTM Zone:

Stack ID	Identify all Emission Units (with Process ID) and Control Devices that Feed to Stack	Stack Physical Data			Stack UTM Coordinates		Stack Gas Stream Data		
		Equivalent Diameter (ft)	Height (ft)	Base Elevation (ft)	Northing (m)	Easting (m)	Flowrate (acfm)	Temperature (°F)	Exit Velocity (ft/sec)
Regenerative Thermal Oxidizer	See Attached Process Flow Diagram	2.33	38	904	4316645.0 N	707069.0 E	10,000	90 - 120	38.98
Dust Collector - Sawing	See Attached Process Flow Diagram	2	18	904	4316645.0 N	707069.0 E	10,000	85	50.4
Dust Collector - Briquetter	See Attached Process Flow Diagram	0.67	23.5	904	4316645.0 N	707069.0 E	1274	80	60.83

Section N.3: Fugitive Information

UTM Zone:

Emission Unit #	Emission Unit Name	Process ID	Area Physical Data		Area UTM Coordinates		Area Release Data	
			Length of the X Side <i>(ft)</i>	Length of the Y Side <i>(ft)</i>	Northing <i>(m)</i>	Easting <i>(m)</i>	Release Temperature <i>(°F)</i>	Release Height <i>(ft)</i>
NA								

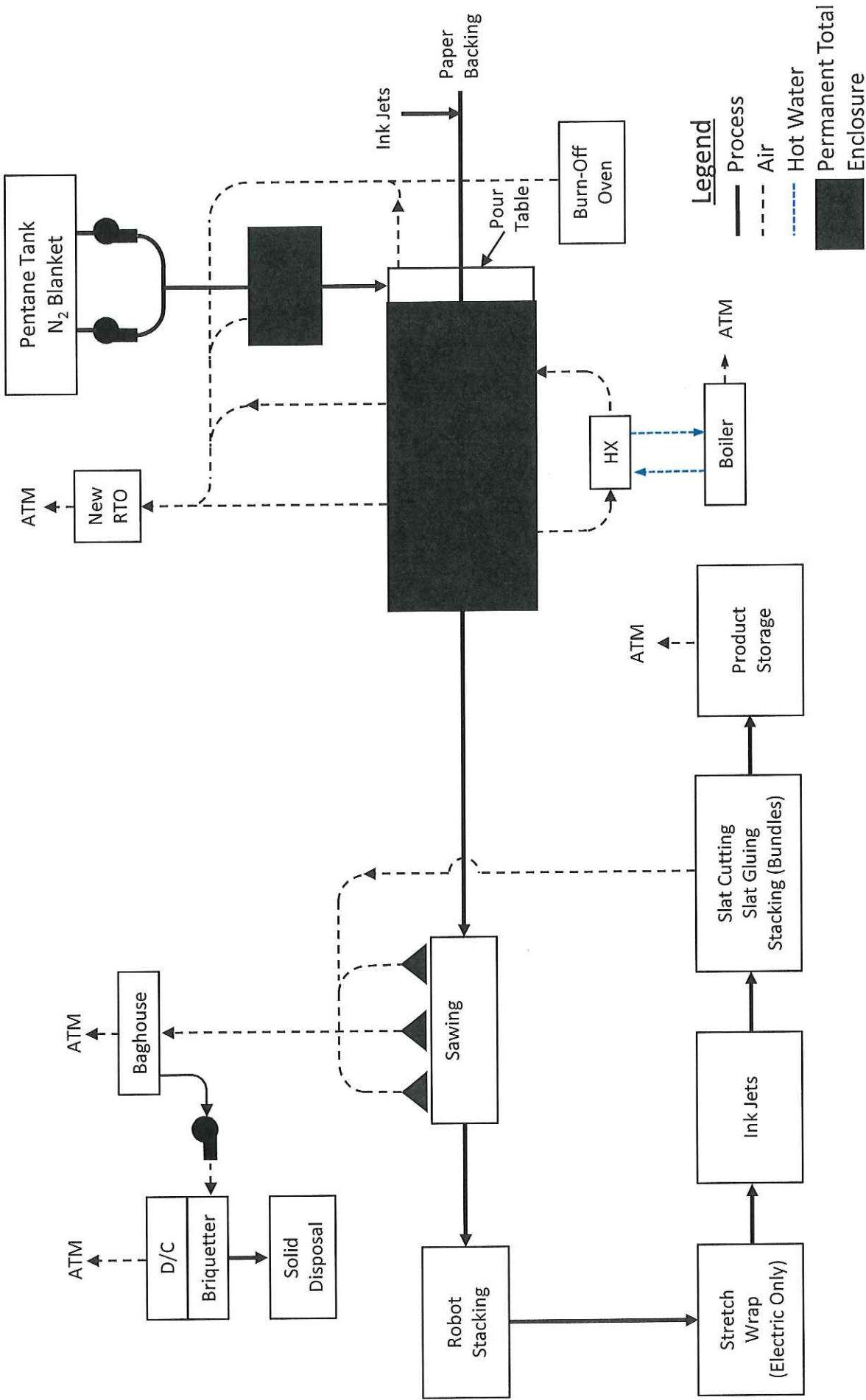

Date: April 13, 2020
 Edited By: CCV

Firestone Building Products - Florence
 Facility Process Flow Diagram





October 27, 2025

Department of Environmental Protection
Division of Air Quality
300 Sower Blvd, 2nd Floor
Frankfort, KY 40601

Re: Amrize Building Envelope, LLC
Source ID: 21-117-00177

Dear Permit Reviewer,

DECA Environmental & Associates, Inc. (DECA), on behalf of Amrize Building Envelope, LLC (Amrize), is submitting the enclosed air permit renewal application for review and processing. The Amrize facility is located at 8170 Holton Drive, Florence, Kentucky 41042.

As part of this renewal submission, Amrize respectfully requests the removal of the current total capture efficiency testing requirement associated with the Laminator Enclosure and Chemical Pump Enclosure (Emission Unit EU-002). The enclosed technical support letter provides the justification for this revision.

EPA guidance recognizes capture efficiency as a design-dependent parameter. Verification testing is only necessary following a significant physical or operational modification that could impact the capture system's performance. Since no modifications have occurred at the facility since issuance of the existing permit, Amrize proposes that the permit condition be revised so that capture efficiency testing is required only if a future equipment or process change has the potential to affect capture efficiency.

Provided with this letter are the DEP7007 AI, DEP7007N Forms and a Regulatory Review Summary for the removal of the capture efficiency testing of the RTO-2.

Once the permit reviewer is assigned, please contact Jim Euler at (317) 575-0095 or jeuler@decaenvironmental.com to discuss the application.

Sincerely,

A handwritten signature in black ink that reads "Jim B. Euler". The signature is written in a cursive style with a prominent initial "J".

Jim B. Euler

President | DECA Environmental & Associates, Inc.
410 1st Ave. NE | Carmel, IN 46032
Office: (317) 575-0095 | Cell: (317) 919-0491

Enclosures

DECA Environmental & Associates, Inc.

410 1st Ave. NE • Carmel, IN 46032 • (317) 575-0095 • Fax (317) 575-0096 • E-mail deca@indy.net

Attachment 1

Request to Remove Capture Efficiency Retesting Requirement

To: Kentucky Department for Environmental Protection
Division for Air Quality

From: Jim Euler
DECA Environmental (Environmental Consultant)
On behalf of Amrize Building Envelope LLC

Date: October 27, 2025

Subject: Air Permit Renewal – RTO-2 Capture Efficiency Retesting Requirement

Dear Division Permit Reviewer,

On behalf of Amrize Building Envelope LLC, this letter provides justification for the removal of the capture efficiency retesting requirement from the draft air permit renewal conditions associated with RTO-2 and the Laminator Enclosure and Chemical Pump Enclosure (Emission Unit EU-002).

Background:

RTO-2 serves as a control device for volatile organic compound (VOC) emissions from EU-002. The unit successfully completed initial performance testing on August 10, 2021, demonstrating compliance with both the capture efficiency and destruction efficiency requirements established under 401 KAR 50:055, Section 2(1)(a).

Since that time, the facility has not made any physical, mechanical, or operational modifications to the RTO, associated enclosures, or ductwork that could affect capture efficiency or control performance. The facility continues to maintain parametric monitoring (including combustion temperature and pressure differential) confirming continuous compliant operation.

Regulatory Basis:

401 KAR 50:055, Section 2(1)(a) requires initial performance testing within 180 days after initial start-up or achieving maximum production rate. As RTO-2 has been in continuous operation since its initial start-up and has not undergone reconstruction or modification (as defined in 401 KAR 51:001, Section 1(102)), the regulatory trigger for a new performance test has not been met.

Furthermore, 401 KAR 50:045, Section 1 authorizes the Division to require testing “as may be necessary to determine compliance.” However, this authority is discretionary and intended to ensure representativeness when process or control conditions have changed. In this case, the previous performance test results remain valid and representative of current operation.

EPA’s Guidelines for Determining Capture Efficiency (1995) similarly recognize that capture efficiency is a design-dependent parameter. Retesting is warranted only when the physical configuration or operating conditions of the capture system have been altered. No such changes have occurred at Amrize Building Envelope LLC.

Request:

Amrize respectfully requests that the following language be used in the permit renewal to replace the current capture efficiency retesting condition:

“Subsequent capture efficiency testing shall only be required if modifications occur that may reasonably be expected to alter the capture or destruction efficiency of RTO-2.”

This approach maintains the Division’s authority to require testing when warranted while avoiding redundant and unnecessary performance testing for unchanged systems.

Conclusion:

Given the absence of any equipment or operational changes since the 2021 approved test, the continued compliance of RTO-2 based on parametric monitoring, and the regulatory intent of 401 KAR 50:045 and 50:055, Amrize Building Envelope LLC requests that the capture efficiency retesting requirement be removed or modified as proposed above.

Please contact me at 317-575-0095 or jeuler@decaenvironmental.com if additional information or documentation is needed.

Respectfully submitted,

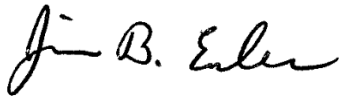

Jim Euler
DECA Environmental
On behalf of Amrize Building Envelope LLC

Division for Air Quality 300 Sower Boulevard Frankfort, KY 40601 (502) 564-3999	DEP7007AI Administrative Information ___ Section AL.1: Source Information ___ Section AL.2: Applicant Information ___ Section AL.3: Owner Information ___ Section AL.4: Type of Application ___ Section AL.5: Other Required Information ___ Section AL.6: Signature Block ___ Section AL.7: Notes, Comments, and Explanations	Additional Documentation ___ Additional Documentation attached
Source Name: <u>Amrize Building Envelope, LLC</u>		
KY EIS (AFS) #: <u>21- 117-00177</u>		
Permit #: <u>F-20-027 R2</u>		
Agency Interest (AI) ID: <u>71732</u>		
Date: _____		
Section AL.1: Source Information		
Physical Location Address:	Street: <u>8170 Holton Dr.</u> City: <u>Florence</u> County: <u>Keton</u> Zip Code: <u>41042-3010</u>	Mailing Address:
Street or P.O. Box:	<u>8170 Holton Dr.</u> City: <u>Florence</u> State: <u>KY</u> Zip Code: <u>41042-3010</u>	
Standard Coordinates for Source Physical Location		
Longitude: <u>38.970291</u> (decimal degrees) Latitude: <u>-84.609314</u> (decimal degrees)		
Primary (NAICS) Category: <u>Urethane and Other Fom Product Manufacturing</u> Primary NAICS #: <u>326150</u>		

Classification (SIC) Category:	<u>Foam Insulating Manufacturing</u>	Primary SIC #:	<u>3086</u>
Briefly discuss the type of business conducted at this site:			
Description of Area Surrounding Source:			
<input type="checkbox"/> Rural Area	<input type="checkbox"/> Industrial Park	<input type="checkbox"/> Residential Area	Is any part of the source located on federal land?
<input type="checkbox"/> Urban Area	<input checked="" type="checkbox"/> Industrial Area	<input type="checkbox"/> Commercial Area	<input type="checkbox"/> Yes <input type="checkbox"/> No
Approximate distance to nearest residence or commercial property: <u>acent business and residen</u>			Property Area: _____
Is this source portable? <input type="checkbox"/> Yes <input checked="" type="checkbox"/> No			
What other environmental permits or registrations does this source currently hold or need to obtain in Kentucky?			
NPDES/KPDES:	<input checked="" type="checkbox"/> Currently Hold	<input type="checkbox"/> Need	<input checked="" type="checkbox"/> N/A
Solid Waste:	<input type="checkbox"/> Currently Hold	<input type="checkbox"/> Need	<input checked="" type="checkbox"/> N/A
RCRA:	<input type="checkbox"/> Currently Hold	<input type="checkbox"/> Need	<input checked="" type="checkbox"/> N/A
UST:	<input type="checkbox"/> Currently Hold	<input type="checkbox"/> Need	<input checked="" type="checkbox"/> N/A
Type of Regulated Waste Activity:			
<input type="checkbox"/> Mixed Waste Generator	<input type="checkbox"/> Generator	<input type="checkbox"/> Recycler	<input checked="" type="checkbox"/> Other: _____
<input type="checkbox"/> U.S. Importer of Hazardous Waste	<input type="checkbox"/> Transporter	<input type="checkbox"/> Treatment/Storage/Disposal Facility	<input checked="" type="checkbox"/> N/A

Section AI.2: Applicant Information	
Applicant Name:	<u>Amrize Building Envelope, LLC</u>
Title: (if individual)	<u>Plant Manager</u>
Mailing Address:	Street or P.O. Box: <u>8170 Holton Dr.</u>
	City: <u>Florence</u> State: <u>KY</u> Zip Code: <u>41042</u>
Email: (if individual)	<u>jesse.megenhardt@amrize.com</u>
Phone:	<u>502-525-0774</u>
Technical Contact	
Name:	<u>Burton Joyner</u>
Title:	<u>Regional EHSS Manager</u>
Mailing Address:	Street or P.O. Box: <u>8170 Holton Dr.</u>
	City: <u>Florence</u> State: <u>KY</u> Zip Code: <u>41042</u>
Email:	<u>burton.joyner@amrize.com</u>
Phone:	<u>859-490-1564</u>
Air Permit Contact for Source	
Name:	<u>Burton Joyner</u>
Title:	<u>Regional EHSS Manager</u>
Mailing Address:	Street or P.O. Box: <u>8170 Holton Dr.</u>
	City: <u>Florence</u> State: <u>KY</u> Zip Code: <u>41042-3010</u>
Email:	<u>burton.joyner@amrize.com</u>
Phone:	<u>859-490-1564</u>

Section AI.3: Owner Information	
<input checked="" type="checkbox"/> Owner same as applicant	
Name:	_____
Title:	_____
Mailing Address:	Street or P.O. Box: _____
	City: _____ State: _____ Zip Code: _____
Email:	_____
Phone:	_____
List names of owners and officers of the company who have an interest in the company of 5% or more.	
Name	Position
_____	_____
_____	_____
_____	_____

Section AI.4: Type of Application			
Current Status:	<input type="checkbox"/> Title V <input checked="" type="checkbox"/> Conditional Major <input type="checkbox"/> State-Origin <input type="checkbox"/> General Permit <input type="checkbox"/> Registration <input type="checkbox"/> None		
	<input type="checkbox"/> Name Change <input type="checkbox"/> Initial Registration <input type="checkbox"/> Significant Revision <input type="checkbox"/> Administrative Permit Amendment		
Requested Action: <i>(check all that apply)</i>	<input checked="" type="checkbox"/> Renewal Permit <input type="checkbox"/> Revised Registration <input type="checkbox"/> Minor Revision <input type="checkbox"/> Initial Source-wide Operating Permit		
	<input type="checkbox"/> 502(b)(10) Change <input type="checkbox"/> Extension Request <input type="checkbox"/> Addition of New Facility <input type="checkbox"/> Portable Plant Relocation Notice		
	<input type="checkbox"/> Revision <input type="checkbox"/> Off Permit Change <input type="checkbox"/> Landfill Alternate Compliance Submittal <input type="checkbox"/> Modification of Existing Facilities		
	<input type="checkbox"/> Ownership Change <input type="checkbox"/> Closure		
Requested Status:	<input type="checkbox"/> Title V <input checked="" type="checkbox"/> Conditional Major <input type="checkbox"/> State-Origin <input type="checkbox"/> PSD <input type="checkbox"/> NSR <input type="checkbox"/> Other: _____		
Is the source requesting a limitation of potential emissions? <input type="checkbox"/> Yes <input checked="" type="checkbox"/> No			
Pollutant:	Requested Limit:	Pollutant:	Requested Limit:
<input type="checkbox"/> Particulate Matter _____		<input type="checkbox"/> Single HAP _____	
<input type="checkbox"/> Volatile Organic Compounds (VOC) _____		<input type="checkbox"/> Combined HAPs _____	
<input type="checkbox"/> Carbon Monoxide _____		<input type="checkbox"/> Air Toxics (40 CFR 68, Subpart F) _____	
<input type="checkbox"/> Nitrogen Oxides _____		<input type="checkbox"/> Carbon Dioxide _____	
<input type="checkbox"/> Sulfur Dioxide _____		<input type="checkbox"/> Greenhouse Gases (GHG) _____	
<input type="checkbox"/> Lead _____		<input type="checkbox"/> Other _____	
For New Construction:			
Proposed Start Date of Construction: <i>(MM/YYYY)</i> _____		Proposed Operation Start-Up Date: <i>(MM/YYYY)</i> _____	
For Modifications:			
Proposed Start Date of Modification: <i>(MM/YYYY)</i> _____		Proposed Operation Start-Up Date: <i>(MM/YYYY)</i> _____	
Identify any non-applicable requirements for which permit shield is sought on a separate attachment to the application.			
<input type="checkbox"/> Applicant is seeking coverage under a permit shield. <input type="checkbox"/> Yes <input checked="" type="checkbox"/> No			

Section AI.5 Other Required Information	
Indicate the documents attached as part of this application:	
<input type="checkbox"/> DEP7007A Indirect Heat Exchangers and Turbines <input type="checkbox"/> DEP7007B Manufacturing or Processing Operations <input type="checkbox"/> DEP7007C Incinerators and Waste Burners <input type="checkbox"/> DEP7007F Episode Standby Plan <input type="checkbox"/> DEP7007J Volatile Liquid Storage <input type="checkbox"/> DEP7007K Surface Coating or Printing Operations <input type="checkbox"/> DEP7007L Mineral Processes <input type="checkbox"/> DEP7007M Metal Cleaning Degreasers <input type="checkbox"/> DEP7007N Source Emissions Profile <input type="checkbox"/> DEP7007P Perchloroethylene Dry Cleaning Systems <input type="checkbox"/> DEP7007R Emission Offset Credit <input type="checkbox"/> DEP7007S Service Stations <input type="checkbox"/> DEP7007T Metal Plating and Surface Treatment Operations <input type="checkbox"/> DEP7007V Applicable Requirements and Compliance Activities <input type="checkbox"/> DEP7007Y Good Engineering Practice and Stack Height Determination <input type="checkbox"/> DEP7007AA Compliance Schedule for Non-complying Emission Units <input type="checkbox"/> DEP7007BB Certified Progress Report	<input type="checkbox"/> DEP7007CC Compliance Certification <input type="checkbox"/> DEP7007DD Insignificant Activities <input type="checkbox"/> DEP7007EE Internal Combustion Engines <input type="checkbox"/> DEP7007FF Secondary Aluminum Processing <input type="checkbox"/> DEP7007GG Control Equipment <input type="checkbox"/> DEP7007HH Haul Roads <input type="checkbox"/> Confidentiality Claim <input type="checkbox"/> Ownership Change Form <input type="checkbox"/> Secretary of State Certificate <input type="checkbox"/> Flowcharts or diagrams depicting process <input type="checkbox"/> Digital Line Graphs (DLG) files of buildings, roads, etc. <input type="checkbox"/> Site Map <input type="checkbox"/> Map or drawing depicting location of facility <input type="checkbox"/> Safety Data Sheet (SDS) <input type="checkbox"/> Emergency Response Plan <input type="checkbox"/> Other: _____

Section AI.6: Signature Block	
<p>I, the undersigned, hereby certify under penalty of law, that I am a responsible official*, and that I have personally examined, and am familiar with, the information submitted in this document and all its attachments. Based on my inquiry of those individuals with primary responsibility for obtaining the information, I certify that the information is on knowledge and belief, true, accurate, and complete. I am aware that there are significant penalties for submitting false or incomplete information, including the possibility of fine or imprisonment.</p>	
_____ Authorized Signature	_____ Date
_____ Jesse Megenhardt	_____ Plant Manager
_____ Type or Printed Name of Signatory	_____ Title of Signatory
*Responsible official as defined by 401 KAR 52:001.	

Section AI.7: Notes, Comments, and Explanations
Once the permit writer is assigned, Amrize would like to discuss the removal of the capture efficiency requirements.
Included with the cover letter is a Technical Rule Review

Section A1.4: Type of Application

Current Status: Title V Conditional Major State-Origin General Permit Registration None

Requested Action: Name Change Initial Registration Significant Revision Administrative Permit Amendment
 Renewal Permit Revised Registration Minor Revision Initial Source-wide Operating Permit
 503(b)(10) Change Extension Request Addition of New Facility Peritable Plant Relocation Notice
 Revision Off-Permit Change Landfill Alternate Compliance Submittal Modification of Existing Facilities
 Ownership Change Closure

Requested Status: Title V Conditional Major State-Origin PSD NSR Other: _____

Is the source requesting a limitation of potential emissions? Yes No

Pollutant:	Requested Limit:	Pollutant:	Requested Limit:
<input type="checkbox"/> Particulate Matter	_____	<input type="checkbox"/> Single HAP	_____
<input type="checkbox"/> Volatile Organic Compounds (VOC)	_____	<input type="checkbox"/> Combined HAPs	_____
<input type="checkbox"/> Carbon Monoxide	_____	<input type="checkbox"/> Air Toxics (40 CFR 68 Subpart F)	_____
<input type="checkbox"/> Nitrogen Oxides	_____	<input type="checkbox"/> Carbon Dioxide	_____
<input type="checkbox"/> Sulfur Dioxide	_____	<input type="checkbox"/> Greenhouse Gases (GHG)	_____
<input type="checkbox"/> Lead	_____	<input type="checkbox"/> Other	_____

For New Construction:
 Proposed Start Date of Construction: (MM/YY) _____ Proposed Operation Start-Up Date: (MM/YY) _____

For Modifications:
 Proposed Start Date of Modification: (MM/YY) _____ Proposed Operation Start-Up Date: (MM/YY) _____

Applicant is seeking coverage under a permit shield. Yes No Identify any non-applicable requirements for which permit shield is sought on a separate attachment to the application.

Section A1.5 Other Required Information

Indicate the documents attached as part of this application:

<input type="checkbox"/> DEP7007A Indirect Heat Exchangers and Turbines	<input type="checkbox"/> DEP7007C Compliance Certification
<input type="checkbox"/> DEP7007B Manufacturing or Processing Operations	<input type="checkbox"/> DEP7007D Insignificant Activities
<input type="checkbox"/> DEP7007C Incinerators and Waste Burners	<input type="checkbox"/> DEP7007E Internal Combustion Engines
<input type="checkbox"/> DEP7007F Episodic Standby Plan	<input type="checkbox"/> DEP7007F Internal Aluminum Processing
<input type="checkbox"/> DEP7007G Volatile Liquid Storage	<input type="checkbox"/> DEP7007G Central Equipment
<input type="checkbox"/> DEP7007K Surface Coating or Finishing Operations	<input type="checkbox"/> DEP7007H Haul Roads
<input type="checkbox"/> DEP7007L Mineral Processes	<input type="checkbox"/> Confidentiality Claim
<input type="checkbox"/> DEP7007M Metal Cleaning Degreasers	<input type="checkbox"/> Ownership Change Form
<input type="checkbox"/> DEP7007N Source Emissions Profile	<input type="checkbox"/> Secretary of State Certificate
<input type="checkbox"/> DEP7007P Perchloroethylene Dry-Cleaning Systems	<input type="checkbox"/> Flowcharts or diagrams depicting process
<input type="checkbox"/> DEP7007R Emission Offset Credit	<input type="checkbox"/> Digital Line Graphs (DLG) files of buildings, roads, etc.
<input type="checkbox"/> DEP7007S Service Stations	<input type="checkbox"/> Site Map
<input type="checkbox"/> DEP7007T Metal Plating and Surface Treatment Operations	<input type="checkbox"/> Map or drawing depicting location of facility
<input type="checkbox"/> DEP7007V Applicable Requirements and Compliance Activities	<input type="checkbox"/> Safety Data Sheet (SDS)
<input type="checkbox"/> DEP7007Y Good Engineering Practice and Stack Height Determination	<input type="checkbox"/> Emergency Response Plan
<input type="checkbox"/> DEP7007AA Compliance Schedule for Non-complying Emission Units	<input type="checkbox"/> Other: _____
<input type="checkbox"/> DEP7007BB Certified Progress Report	

Section A1.6: Signature Block

I, the undersigned, hereby certify under penalty of law, that I am a responsible official* and that I have personally examined, and am familiar with, the information submitted in this document and all its attachments. Based on my inquiry of those individuals with primary responsibility for obtaining the information, I certify that the information is on knowledge and belief, true, accurate, and complete. I am aware that there are significant penalties for submitting false or incomplete information, including the possibility of fine or imprisonment.

Authorized Signature

Date
 10/27/25

Type or Printed Name of Signatory
 Jesse Meyerhand

Title of Signatory
 Plant Manager

*Responsible official as defined by 401 KAR 22.001.

Division for Air Quality 300 Sower Boulevard Frankfort, KY 40601 (502) 564-3999	DEP7007N Source Emissions Profile ___ Section N.1: Emission Summary ___ Section N.2: Stack Information ___ Section N.3: Fugitive Information ___ Section N.4: Notes, Comments, and Explanations	<table border="1" style="width: 100%; border-collapse: collapse;"> <tr> <th style="text-align: center;">Additional Documentation</th> </tr> <tr> <td style="padding: 5px;">___ Complete DEP7007AI</td> </tr> </table>	Additional Documentation	___ Complete DEP7007AI
Additional Documentation				
___ Complete DEP7007AI				

Source Name:	Amrize Building Envelope, LLC
KY EIS (AFS) #:	21- 117-00177
Permit #:	F-20-027 R2
Agency Interest (AI) ID:	71732
Date:	10/13/2025

N.1: Emission Summary

Emission Unit #	Emission Unit Name	Process ID	Process Name	Control Device Name	Control Device ID	Stack ID	Maximum Design Capacity (SCC Units/hour)	Pollutant	Uncontrolled Emission Factor (lb/SCC Units)	Emission Factor Source (e.g. AP-42, Stack Test, Mass Balance)	Capture Efficiency (%)	Control Efficiency (%)	Hourly Emissions		Annual Emissions	
													Uncontrolled Potential (lb/hr)	Controlled Potential (lb/hr)	Uncontrolled Potential (tons/yr)	Controlled Potential (tons/yr)
1	Trim/Sawing Formboard			Dust Collector-Sawing				PM	See 2020 Calculations	See 2020 Calculations	99.50%	99.00%	163.38	1.63	715.59	7.16
1	Trim/Sawing Formboard							VOC	See 2020 Calculations	See 2020 Calculations					57.25	57.25
1	Trim/Sawing Formboard			Dust Collector-Sawing				PM	See 2020 Calculations	See 2020 Calculations	100%	99.00%	21.01	0.21	92.01	0.92
2	Foam Board Precessing Laminator			RTO				VOC	See 2020 Calculations	See 2020 Calculations	100%	96%			347.38	13.9
2	Foam Board Precessing Laminator			RTO				MDI	See 2020 Calculations	See 2020 Calculations	100%	96%			0.18	0.0072
2	Foam Board Precessing Laminator							Natural Gas Combustion in RTO	Natural Gas Combustion in RTO							
2	Foam Board Precessing Laminator							PM10	7.6 lb/10exp6 scf	AP-42			0.02	0.02	0.08	0.08
2	Foam Board Precessing Laminator							PM2.5	7.6 lb/10exp6 scf	AP-42			0.02	0.02	0.08	0.08
2	Foam Board Precessing Laminator							NOx	100 lb/10exp6 scf	AP-42			0.24	0.24	1.03	1.03
2	Foam Board Precessing Laminator							Natural Gas Combustion in RTO	Natural Gas Combustion in RTO							
2	Foam Board Precessing Laminator							CO	84 lb/10exp5 scf	AP-42			0.2	0.2	0.87	0.87
2	Foam Board Precessing Laminator							SO2	0.6 lb/10exp5 scf	AP-42			1.41E-03	1.41E-03	0.006	0.006
2	Foam Board Precessing Laminator							VOC	5.5 lb/10exp5 scf	AP-42			0.01	0.01	0.06	0.06
FUG 02	Foam Board Precessing Fugitive Laydown							VOC	See 2020 Calculations	See 2020 Calculations					14.47	14.47
FUG 02	Foam Board Precessing Fugitive Laydown							MDI	See 2020 Calculations	See 2020 Calculations					0.0075	0.0075
FUG 04	Warehouse - Fugitive							VOC	See 2020 Calculations	See 2020 Calculations					36.68	36.68

Section N.2: Stack Information

UTM Zone:

Stack ID	Identify all Emission Units (with Process ID) and Control Devices that Feed to Stack	Stack Physical Data			Stack UTM Coordinates		Stack Gas Stream Data		
		Equivalent Diameter (ft)	Height (ft)	Base Elevation (ft)	Northing (m)	Easting (m)	Flowrate (acfm)	Temperature (°F)	Exit Velocity (ft/sec)
Regenerative Thermal Oxidizer	See Attached Process Flow Diagram	2.33	38	904	4316645.0 N	707069.0 E	10,000	90 - 120	38.98
Dust Collector - Sawing	See Attached Process Flow Diagram	2	18	904	4316645.0 N	707069.0 E	10,000	85	50.4
Dust Collector - Briquetter	See Attached Process Flow Diagram	0.67	23.5	904	4316645.0 N	707069.0 E	1274	80	60.83

Section N.3: Fugitive Information

UTM Zone:

Emission Unit #	Emission Unit Name	Process ID	Area Physical Data		Area UTM Coordinates		Area Release Data	
			Length of the X Side <i>(ft)</i>	Length of the Y Side <i>(ft)</i>	Northing <i>(m)</i>	Easting <i>(m)</i>	Release Temperature <i>(°F)</i>	Release Height <i>(ft)</i>
NA								

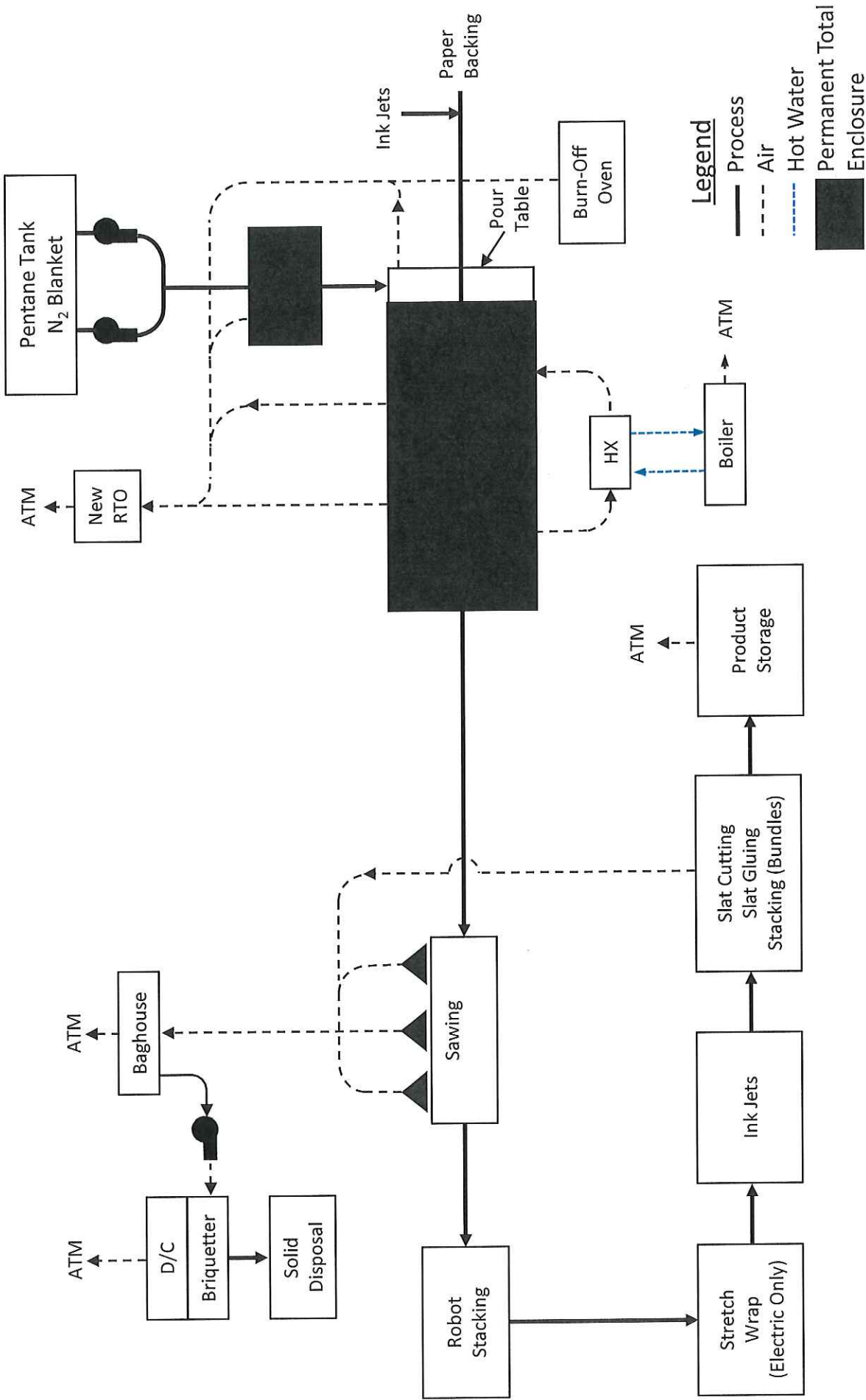

Date: April 13, 2020
 Edited By: CCV

Firestone Building Products - Florence
 Facility Process Flow Diagram





RE: AI 71732 - Amrize Building Envelope LLC - Pentane Tank NSPS Kb Applicability

From Jim Euler <JEuler@decaenvironmental.com>

Date Mon 11/17/2025 9:57 AM

To Freeman, Colby (EEC) <colby.freeman@ky.gov>; jesse.megenhardt@amrize.com <jesse.megenhardt@amrize.com>; burton.joyner@amrize.com <burton.joyner@amrize.com>

Cc Ross, Dakota D (EEC) <dakota.ross@ky.gov>

This Message Originated from Outside the Organization

This Message Is From an External Sender.

Report Suspicious

Burton and Jesse,

Please contact the supplier of the tank and I am assuming the company responsible for the pressure relief valve to verify the lower operating pressure that Colby indicated below.... The conservation vent "is designed to maintain a vessel pressure between 14.9 psi and 2 oz. Vacuum."

Also, verify the tank operates at 250psi. Seems high.

Thanks,

Jim B. Euler

President | [DECA Environmental & Associates, Inc.](#)

Office: (317) 575-0095 | Cell: (317) 919-0491

From: Freeman, Colby (EEC) <colby.freeman@ky.gov>

Sent: Monday, November 17, 2025 9:47 AM

To: jesse.megenhardt@amrize.com; burton.joyner@amrize.com

Cc: Jim Euler <JEuler@decaenvironmental.com>; Ross, Dakota D (EEC) <dakota.ross@ky.gov>

Subject: AI 71732 - Amrize Building Envelope LLC - Pentane Tank NSPS Kb Applicability

Dear Mr. Megenhardt,

The Division requires additional information regarding the 45,000-gallon pentane storage tank at the Amrize Building Envelope, LLC facility in Florence, KY.

The Division's records indicate a 45,000-gallon fixed roof pressurized tank is utilized for pentane storage prior to blending with "B-side" materials. According to the initial Conditional Major Application received May 17, 2005, "the tank will be maintained under pressure (250 psi)... no emissions will be vented to the atmosphere."

However, during an inspection at the facility on October 3, 2016, the Division's inspectors identified emissions from the conservation vent on the pentane storage tank. In response, the facility ("Firestone" at the time) stated the tank was built to operate under a maximum allowable working pressure of 250 psi. The conservation vent "is designed to maintain a vessel pressure between 14.9 psi and 2 oz. Vacuum."

Based on this information, the Division believes this tank may be subject to 40 CFR 60, Subpart Kb. The definition of "storage vessel" under Subpart Kb does not exclude components that are "directly involved in the containment of liquids or vapors". As the conservation vent is "designed to relieve pressure" above 14.9 psi (by releasing emissions), the vessel does not meet the criteria for exemption under 40 CFR 60.110b(d)(2): "Pressure vessels designed to operate in excess of 204.9 kPa (29.71 psi) *and* without emissions to the atmosphere" (emphasis added). As no other exemptions apply, the capacity of the tank is greater than 151 cubic meters (m³), the maximum true vapor pressure of pentane is greater than 3.5 kilopascals (kPa), and the tank was constructed after July 23, 1984, and before October 4, 2023, Subpart Kb applies.

If you disagree with this determination, please provide justification and any supporting documentation as to why 40 CFR 60, Subpart Kb does not apply to the 45,000-gallon pentane storage tank. Otherwise, please provide a DEP7007V form outlining the requirements which apply to the tank and how the facility intends to comply.

Thanks,

Colby Freeman

Environmental Engineer Technologist I
Chemical Section
Division for Air Quality
300 Sower Blvd
Frankfort, KY 40601
(502) 782 - 6671



Re: AI 71732 - Amrize Building Envelope LLC - Pentane Tank NSPS Kb Applicability

From Burton JOYNER <burton.joyner@amrize.com>

Date Wed 11/19/2025 11:08 AM

To Freeman, Colby (EEC) <colby.freeman@ky.gov>

Cc jesse.megenhardt@amrize.com <jesse.megenhardt@amrize.com>; jeuler@decaenvironmental.com <jeuler@decaenvironmental.com>; Ross, Dakota D (EEC) <dakota.ross@ky.gov>; Justin SMITH <justin.smith2@amrize.com>

This Message Originated from Outside the Organization

This Message Is From an External Sender.

Report Suspicious

Hi Colby,

Could you send us a copy of the 2016 inspection report for the pentane tank's conservation vent? We have located only a hard copy of the site's response to the inspection. I think the confusion stems from the state assuming we operate the storage tank as a high-pressure vessel, which we do not.

Anyway, sharing a copy of the 2016 inspection report would help us form a more accurate response to this recent inquiry.

Thank you for your support.

On Tue, Nov 18, 2025 at 8:15 AM Burton JOYNER <burton.joyner@amrize.com> wrote:

Good morning Colby,

Thanks for reaching out about this. As far as I know, the relief valve does not discharge at all during normal operations; it is present only for emergency release. The release setting is 14.9 psig, so it would only open if the internal pressure was 14.9 psi over atmospheric pressure, i.e. ~30 psia. Additionally, the pentane in the tank is covered at all times with a nitrogen blanket, so if an emergency release were to occur, the vented material would likely be solely nitrogen gas.

All that said, Amrize takes its environmental responsibilities and regulatory compliance very seriously. We have started internal discussions with our corporate environmental team and process engineers to make sure we are indeed in compliance with 40 CFR 60 subpart Kb. I hope to provide an official response to your team by the end of the week.

Thanks for all you do. Back in touch soon.

Burton

On Mon, Nov 17, 2025 at 9:47 AM Freeman, Colby (EEC) <colby.freeman@ky.gov> wrote:

Dear Mr. Megenhardt,

The Division requires additional information regarding the 45,000-gallon pentane storage tank at the Amrize Building Envelope, LLC facility in Florence, KY.

The Division's records indicate a 45,000-gallon fixed roof pressurized tank is utilized for pentane storage prior to blending with "B-side" materials. According to the initial Conditional Major Application received May 17, 2005, "the tank will be maintained under pressure (250 psi)... no emissions will be vented to the atmosphere."

However, during an inspection at the facility on October 3, 2016, the Division's inspectors identified emissions from the conservation vent on the pentane storage tank. In response, the facility ("Firestone" at the time) stated the tank was built to operate under a maximum allowable working pressure of 250 psi. The conservation vent "is designed to maintain a vessel pressure between 14.9 psi and 2 oz. Vacuum."

Based on this information, the Division believes this tank may be subject to 40 CFR 60, Subpart Kb. The definition of "storage vessel" under Subpart Kb does not exclude components that are "directly involved in the containment of liquids or vapors". As the conservation vent is "designed to relieve pressure" above 14.9 psi (by releasing emissions), the vessel does not meet the criteria for exemption under 40 CFR 60.110b(d)(2): "Pressure vessels designed to operate in excess of 204.9 kPa (29.71 psi) *and* without emissions to the atmosphere" (emphasis added). As no other exemptions apply, the capacity of the tank is greater than 151 cubic meters (m³), the maximum true vapor pressure of pentane is greater than 3.5 kilopascals (kPa), and the tank was constructed after July 23, 1984, and before October 4, 2023, Subpart Kb applies.

If you disagree with this determination, please provide justification and any supporting documentation as to why 40 CFR 60, Subpart Kb does not apply to the 45,000-gallon pentane storage tank. Otherwise, please provide a DEP7007V form outlining the requirements which apply to the tank and how the facility intends to comply.

Thanks,
Colby Freeman

Environmental Engineer Technologist I
Chemical Section
Division for Air Quality
300 Sower Blvd
Frankfort, KY 40601
(502) 782 - 6671



Re: AI 71732 - Amrize Building Envelope LLC - Pentane Tank NSPS Kb Applicability

From Jesse MEGENHARDT <jesse.megenhardt@amrize.com>

Date Mon 11/24/2025 3:39 PM

To Freeman, Colby (EEC) <colby.freeman@ky.gov>

Cc burton.joyner@amrize.com <burton.joyner@amrize.com>; jeuler@decaenvironmental.com <jeuler@decaenvironmental.com>; Ross, Dakota D (EEC) <dakota.ross@ky.gov>; Paul DE SANTIS <paul.desantis@amrize.com>; Justin SMITH <justin.smith2@amrize.com>

 1 attachment (390 KB)

Amrize Building Envelope LLC – 45,000 gallon Pentane Tank, NSPS 40 CFR Part 60 Subpart Kb Applicability.pdf;

****CAUTION** PDF attachments may contain links to malicious sites. Please contact the COT Service Desk ServiceCorrespondence@ky.gov for any assistance.**

This Message Originated from Outside the Organization

This Message Is From an External Sender.

Report Suspicious

Dear Mr. Freeman,

Please find the attached letter regarding the 45,000-gallon pentane storage tank at our Florence, KY facility.

Given the historical nature of the inquiry and changes in personnel since 2016, we are conducting a comprehensive internal review to gather the necessary design and engineering data. The attached letter outlines our plan to complete this review and provide a formal applicability assessment by **January 9, 2026**.

We appreciate your collaboration as we resolve this matter.

Respectfully,

JESSE MEGENHARDT

Sr. Plant Manager

jesse.megenhardt@amrize.com



Amrize

8170 Holton Drive, Florence, KY, USA, Florence, United States, 41042

T: 41042, M: 5025250774

[Amrize](#) | [LinkedIn](#) | [Facebook](#)



This email is confidential and intended only for the use of the above named addressee. If you have received this email in error, please delete it immediately and notify us by email or telephone.

On Mon, Nov 17, 2025 at 9:47 AM Freeman, Colby (EEC) <colby.freeman@ky.gov> wrote:

Dear Mr. Megenhardt,

The Division requires additional information regarding the 45,000-gallon pentane storage tank at the Amrize Building Envelope, LLC facility in Florence, KY.

The Division's records indicate a 45,000-gallon fixed roof pressurized tank is utilized for pentane storage prior to blending with "B-side" materials. According to the initial Conditional Major Application received May 17, 2005, "the tank will be maintained under pressure (250 psi)... no emissions will be vented to the atmosphere."

However, during an inspection at the facility on October 3, 2016, the Division's inspectors identified emissions from the conservation vent on the pentane storage tank. In response, the facility ("Firestone" at the time) stated the tank was built to operate under a maximum allowable working pressure of 250 psi. The conservation vent "is designed to maintain a vessel pressure between 14.9 psi and 2 oz. Vacuum."

Based on this information, the Division believes this tank may be subject to 40 CFR 60, Subpart Kb. The definition of "storage vessel" under Subpart Kb does not exclude components that are "directly involved in the containment of liquids or vapors". As the conservation vent is "designed to relieve pressure" above 14.9 psi (by releasing emissions), the vessel does not meet the criteria for exemption under 40 CFR 60.110b(d)(2): "Pressure vessels designed to operate in excess of 204.9 kPa (29.71 psi) *and* without emissions to the atmosphere" (emphasis added). As no other exemptions apply, the capacity of the tank is greater than 151 cubic meters (m³), the maximum true vapor pressure of pentane is greater than 3.5 kilopascals (kPa), and the tank was constructed after July 23, 1984, and before October 4, 2023, Subpart Kb applies.

If you disagree with this determination, please provide justification and any supporting documentation as to why 40 CFR 60, Subpart Kb does not apply to the 45,000-gallon pentane storage tank. Otherwise, please provide a DEP7007V form outlining the requirements which apply to the tank and how the facility intends to comply.

Thanks,
Colby Freeman

Environmental Engineer Technologist I
Chemical Section
Division for Air Quality
300 Sower Blvd
Frankfort, KY 40601
(502) 782 - 6671

November 25, 2025

Mr. Colby Freeman
Kentucky Department for Environmental Protection
300 Sower Blvd
Frankfort, KY 40601

RE: Amrize Building Envelope LLC – 45,000 gallon Pentane Tank, NSPS 40 CFR Part 60 Subpart Kb Applicability

Dear Mr. Freeman:

In October 2025, Amrize Building Envelope, LLC (Amrize) submitted an operating permit renewal (F-20-027 R1) application for the Florence, KY Polyiso facility (Source ID: 21-117-00177). Following the timely submission, we received an inquiry regarding the applicability of Title 40 CFR Part 60 Subpart Kb citing communications dating back to October 2016 and the initial application from May 2005. Given the historic nature of these conversations, we thank you for bringing this discussion and the history to our attention.

As expected, there have been changes in management and engineering personnel since the initial application in 2005 and the discussions in 2016; therefore, we initiated a comprehensive internal review to gather historic information, including the tank design basis, to make a formal assessment of Subpart Kb applicability. Given the upcoming holidays and internal resource availability due to planned vacations, we expect that this assessment will be completed within the next few weeks and we will be able to provide our formal applicability assessment by January 9, 2026.

We appreciate your collaboration in resolving this longstanding question and trust that our commitment will satisfy the immediate need of the Department.

If you have any questions in the interim, please feel free to contact me directly at 502-525-0774 or jesse.megenhardt@amrize.com.

Respectfully,



Jesse Megenhardt – Sr. Plant Manager
Amrize Building Envelope LLC



Re: Notice of Deficiency for AI 71732

From Freeman, Colby (EEC) <colby.freeman@ky.gov>

Date Fri 1/9/2026 10:29 AM

To Jesse MEGENHARDT <jesse.megenhardt@amrize.com>

Cc jeuler@decaenvironmental.com <jeuler@decaenvironmental.com>; Justin SMITH <justin.smith2@amrize.com>; Burton JOYNER <burton.joyner@amrize.com>; Ross, Dakota D (EEC) <dakota.ross@ky.gov>; Harley, Brian (EEC) <Brian.Harley@ky.gov>

Jesse,

The Division has received your response.

Thanks,

Colby Freeman

Environmental Engineer Technologist I
Chemical Section
Division for Air Quality
300 Sower Blvd
Frankfort, KY 40601
(502) 782 - 1467

From: Jesse MEGENHARDT <jesse.megenhardt@amrize.com>

Sent: Friday, January 9, 2026 10:13 AM

To: Freeman, Colby (EEC) <colby.freeman@ky.gov>

Cc: jeuler@decaenvironmental.com <jeuler@decaenvironmental.com>; Justin SMITH <justin.smith2@amrize.com>; Burton JOYNER <burton.joyner@amrize.com>; Ross, Dakota D (EEC) <dakota.ross@ky.gov>; Harley, Brian (EEC) <Brian.Harley@ky.gov>

Subject: Re: Notice of Deficiency for AI 71732

****CAUTION** PDF attachments may contain links to malicious sites. Please contact the COT Service Desk ServiceCorrespondence@ky.gov for any assistance.**

This Message Originated from Outside the Organization

This Message Is From an External Sender.

Report Suspicious

Dear Colby,

Please find the attached response regarding the potential applicability of 40 CFR 60, Subpart Kb and the Notice of Deficiency for AI 71732.

Kindly acknowledge receipt of this email.

Best Regards,

JESSE MEGENHARDT

Sr. Plant Manager

jesse.megenhardt@amrize.com



Amrize

8170 Holton Drive, Florence, KY, USA, Florence, United States, 41042

T: 41042, M: 5025250774

[Amrize](#) | [LinkedIn](#) | [Facebook](#)



This email is confidential and intended only for the use of the above named addressee. If you have received this email in error, please delete it immediately and notify us by email or telephone.

On Wed, Dec 10, 2025 at 7:55 AM Freeman, Colby (EEC) <colby.freeman@ky.gov> wrote:

Good morning,

Attached is the first Notice of Deficiency for the Conditional Major renewal application for Amrize Building Envelope LLC. This serves as your official copy and a paper copy will not be sent. We request that you submit the information as soon as possible, but in no case later than January 9, 2026.

Please feel free to contact me if you have any questions or need additional clarification.

Thanks,

Colby Freeman

Environmental Engineer Technologist I

Chemical Section

Division for Air Quality

300 Sower Blvd

Frankfort, KY 40601

(502) 782 - 1467

January 9, 2026

Mr. Colby Freeman
Kentucky Energy and Environment Cabinet
Chemical Section, Division for Air Quality
300 Sower Blvd Frankfort, KY 40601

RE: AI 71732 - Amrize Building Envelope LLC – Pentane Tank NSPS Applicability (F-20-027-R1)

Dear Mr. Freeman,

Amrize Building Envelope, LLC (Amrize) is providing this response to address our understanding of the potential applicability of 40 CFR 60, Subpart Kb to the 45,000-gallon pentane storage vessel at our Florence, KY facility.

Based on an internal review of current operations and the historical data provided by the Division, Amrize acknowledges that the 45,000-gallon pentane storage tank is currently subject to the requirements of 40 CFR 60, Subpart Kb. While the vessel is designed to operate as a pressurized unit, the current configuration of the conservation vent, designed to relieve at 14.9 psi, places the vessel outside the pressure vessel exemption criteria of Subpart Kb.

Amrize is currently evaluating multiple options to bring the storage vessel into compliance with all applicable environmental and safety requirements. In consideration of facility operations, maintenance requirements, and safety standards, our evaluation includes, but is not limited to:

- Emission Controls: Assessing the feasibility of controlling potential emissions from the tank in strict accordance with the standards set forth in Subpart Kb; and
- Pressure Vessel Operation: Leveraging the tank's existing design rating (250 psi) to operate it as a true pressure vessel by installing high-pressure relief equipment that meets the exemption criteria of 40 CFR 60.110b(d)(2).

We appreciate the Department's collaboration as we finalize the safest and most effective path forward. Amrize commits to providing the Division with a proposed solution and implementation plan by February 13, 2026.

If you have any questions regarding our progress or this technical evaluation, please contact me at 502-525-0774 or jesse.megenhardt@amrize.com.

Respectfully,



Jesse Megenhardt - Sr. Plant Manager Amrize Building Envelope LLC



Re: Notice of Deficiency for AI 71732

From Jesse MEGENHARDT <jesse.megenhardt@amrize.com>

Date Fri 2/13/2026 10:09 AM

To Freeman, Colby (EEC) <colby.freeman@ky.gov>

Cc jeuler@decaenvironmental.com <jeuler@decaenvironmental.com>; Justin SMITH <justin.smith2@amrize.com>; Burton JOYNER <burton.joyner@amrize.com>; Ross, Dakota D (EEC) <dakota.ross@ky.gov>; Harley, Brian (EEC) <Brian.Harley@ky.gov>

1 attachment (691 KB)

Amrize Pentane Tank NSPS AI 71732 Response Letter 2-13-26.pdf;

****CAUTION** PDF attachments may contain links to malicious sites. Please contact the COT Service Desk ServiceCorrespondence@ky.gov for any assistance.**

This Message Originated from Outside the Organization

This Message Is From an External Sender.

Report Suspicious

Dear Colby,

Please find attached our proposed solution and implementation plan to address the applicability of 40 CFR, Subpart Kb and the Notice of Deficiency of AL 71732.

Kindly acknowledge the receipt of this email. If you have any questions or concerns please do not hesitate to contact me.

Best Regards,

JESSE MEGENHARDT

Sr. Plant Manager

jesse.megenhardt@amrize.com



Amrize

8170 Holton Drive, Florence, KY, USA, Florence, United States, 41042

T: 41042, M: 5025250774

[Amrize](#) | [LinkedIn](#) | [Facebook](#)



This email is confidential and intended only for the use of the above named addressee. If you have received this email in error, please delete it immediately and notify us by email or telephone.

On Fri, Jan 9, 2026 at 10:29 AM Freeman, Colby (EEC) <colby.freeman@ky.gov> wrote:

Jesse,

The Division has received your response.

Thanks,

Colby Freeman

Environmental Engineer Technologist I
Chemical Section
Division for Air Quality
300 Sower Blvd
Frankfort, KY 40601
(502) 782 - 1467

From: Jesse MEGENHARDT <jesse.megenhardt@amrize.com>

Sent: Friday, January 9, 2026 10:13 AM

To: Freeman, Colby (EEC) <colby.freeman@ky.gov>

Cc: jeuler@decaenvironmental.com <jeuler@decaenvironmental.com>; Justin SMITH <justin.smith2@amrize.com>; Burton JOYNER <burton.joyner@amrize.com>; Ross, Dakota D (EEC) <dakota.ross@ky.gov>; Harley, Brian (EEC) <Brian.Harley@ky.gov>

Subject: Re: Notice of Deficiency for AI 71732

****CAUTION** PDF attachments may contain links to malicious sites. Please contact the COT Service Desk ServiceCorrespondence@ky.gov for any assistance.**

Dear Colby,

Please find the attached response regarding the potential applicability of 40 CFR 60, Subpart Kb and the Notice of Deficiency for AI 71732.

Kindly acknowledge receipt of this email.

Best Regards,

JESSE MEGENHARDT

Sr. Plant Manager

jesse.megenhardt@amrize.com



Amrize

8170 Holton Drive, Florence, KY, USA, Florence, United States, 41042

T: 41042, M: 5025250774

[Amrize](#) | [LinkedIn](#) | [Facebook](#)



This email is confidential and intended only for the use of the above named addressee. If you have received this email in error, please delete it immediately and notify us by email or telephone.

On Wed, Dec 10, 2025 at 7:55 AM Freeman, Colby (EEC) <colby.freeman@ky.gov> wrote:

Good morning,

Attached is the first Notice of Deficiency for the Conditional Major renewal application for Amrize Building Envelope LLC. This serves as your official copy and a paper copy will not be sent. We request that you submit the information as soon as possible, but in no case later than January 9, 2026.

Please feel free to contact me if you have any questions or need additional clarification.

Thanks,

Colby Freeman

Environmental Engineer Technologist I

Chemical Section

Division for Air Quality

300 Sower Blvd

Frankfort, KY 40601

(502) 782 - 1467

February 13, 2026

Mr. Colby Freeman
Kentucky Energy and Environment Cabinet
Chemical Section, Division for Air Quality
300 Sower Blvd, Frankfort, KY 40601

RE: AI 71732 - Amrize Building Envelope LLC – Pentane Tank NSPS Applicability (F-20-027-R1)

Dear Mr. Freeman,

As outlined in our correspondence dated January 9, 2026, Amrize Building Envelope LLC (Amrize) completed a technical evaluation regarding the applicability of 40 CFR 60, Subpart Kb to the 45,000-gallon pentane storage vessel at our Florence, KY facility. In our previous letter, we committed to providing the Division with a proposed solution and implementation plan by February 13, 2026. After reviewing facility operations, maintenance requirements, and safety standards, Amrize has finalized the path forward.

Compliance Strategy: Pressure Vessel Exemption

Amrize has elected to leverage the tank’s existing design pressure rating of 250 pounds per square inch (psi) to operate the unit as a pressure vessel. This will be achieved by upgrading the vessel pressure relief equipment. This upgrade will eliminate the potential for emissions from the tank (as noted by the Division in 2016) and will satisfy the exemption criteria set forth in 40 CFR 60.110b(d)(2). To achieve this, Amrize plans to replace the current low-pressure tank conservation vent with high-pressure relief equipment set to operate in excess of 204.9 kiloPascal (kPa) or 29.7 psi.

NSPS Applicability Determination

Amrize assessed the potential regulatory implications of the upgrade and determined that this change will not cause the tank to be considered a new source as defined by the General Provisions of 40 CFR Part 60. Accordingly, the tank is not subject to the new source requirements of 40 CFR Part 60 Subpart Kc.

- **Modification:** The equipment change does not meet the definition of a "modification" under 40 CFR 60.2.
 - The change will not increase the amount of any air pollutant (to which a standard applies) emitted into the atmosphere by the facility.
 - It will not result in the emission of any air pollutant (to which a standard applies) into the atmosphere not previously emitted.
- **Reconstruction:** The equipment change does not meet the definition of "reconstruction" under 40 CFR 60.15.
 - The fixed capital cost of the new components (the replacement valves) is significantly less than 50 percent of the fixed capital cost that would be required to construct a comparable new vessel.



Implementation Plan

Amrize is currently procuring the necessary high-pressure relief valves. We anticipate the installation and final pressure testing to be completed by July 31, 2026. Once these modifications are complete, the storage vessel will operate as a closed system under the pressure vessel exemption.

If you have any questions regarding this technical evaluation or our planned path forward, please contact me at 502-525-0774 or jesse.megenhardt@amrize.com.

Respectfully,

A handwritten signature in black ink that reads 'Jesse Megenhardt'. The signature is fluid and cursive, with a long horizontal flourish extending from the end of the name.

Jesse Megenhardt - Sr. Plant Manager Amrize Building Envelope LLC



Re: Notice of Deficiency for AI 71732

From Burton JOYNER <burton.joyner@amrize.com>

Date Mon 3/2/2026 2:49 PM

To Freeman, Colby (EEC) <colby.freeman@ky.gov>

Cc Jesse MEGENHARDT <jesse.megenhardt@amrize.com>; Ross, Dakota D (EEC) <dakota.ross@ky.gov>; jeuler@decaenvironmental.com <jeuler@decaenvironmental.com>; Justin SMITH <justin.smith2@amrize.com>; Harley, Brian (EEC) <Brian.Harley@ky.gov>

 4 attachments (12 MB)

Florence Pentane (TK-01) Routine Annual Emissions Accounting for Vapor Balance Control.pdf; Florence Pentane (TK-01) Routine Annual Emissions Not Including Vapor Balance Control.pdf; SDS Isopentane - Acetone Blends Trecora.pdf; FWS-390-A-007-005-Pentane Railcar Offload.xlsx;

****CAUTION** PDF attachments may contain links to malicious sites. Please contact the COT Service Desk ServiceCorrespondence@ky.gov for any assistance.**

This Message Originated from Outside the Organization

This Message Is From an External Sender.

Report Suspicious

Hi Colby,

I have attached the 7007J form(s) and the isopentane/acetone blend SDS as requested. After our discussion Thursday, we still concede the tank is subject to Subpart Kb, but it appears we may already be in full compliance with the rule's control requirements through vapor balancing. In light of this I have included two Routine Annual Emission reports: one that includes the use of the vapor balancing control, and one that does not account for that system. I have also included the output from both scenarios in the 7007J form. To summarize, with the vapor balance control in place, we have the PTE of 0.033% of the total pentane blend used annually compared to a PTE of 0.68% when the control is not accounted for.

Our Florence facility would like to claim and file for the AMEL exception to 40 CFR 60, Subpart Kb, specifically under 40 CFR 60.112b(a)(3) regarding the "use of a closed vent system and control device." As requested, I have included our current SOP for operator offload instructions.

Please let us know the next steps you would like us to take. We appreciate your willingness to help us understand and ensure complete compliance with all regulations.

Burton

On Thu, Feb 26, 2026 at 1:11 PM Freeman, Colby (EEC) <colby.freeman@ky.gov> wrote:

Burton,

Once you have determined the maximum throughput for the tank, please calculate potential emissions using EPA's [TANKS Emissions Estimation Software](#). I have linked you to the homepage for AP-42 Chapter 7 with the TANKS software highlighted. You can look into the other links if you have questions about any of the inputs. Specifically, we are looking for routine losses. TANKS can generate a PDF report which will provide all of the information we need for emissions.

We noticed the 7007J form listed a pentane/acetone mixture. This may require adding a custom organic liquid in TANKS to account for the mixture's vapor pressure. Please provide a material safety data sheet along with the 7007J form and emission calculations.

Here is the link to the docket for the alternative means of emission limitation we discussed today. You can find the facility's application and the EPA's approval conditions in the docket documents: [AMEL](#)

Let me know if you have any questions. Thanks,

Colby Freeman

Environmental Engineer Technologist I
Chemical Section
Division for Air Quality
300 Sower Blvd
Frankfort, KY 40601
(502) 782 - 1467

From: Burton JOYNER <burton.joyner@amrize.com>

Sent: Wednesday, February 25, 2026 1:13 PM

To: Freeman, Colby (EEC) <colby.freeman@ky.gov>

Cc: Jesse MEGENHARDT <jesse.megenhardt@amrize.com>; Ross, Dakota D (EEC) <dakota.ross@ky.gov>; jeuler@decaenvironmental.com <jeuler@decaenvironmental.com>; Justin SMITH <justin.smith2@amrize.com>; Harley, Brian (EEC) <Brian.Harley@ky.gov>

Subject: Re: Notice of Deficiency for AI 71732

Thanks. I sent an invitation for tomorrow at 11AM eastern time.

On Wed, Feb 25, 2026 at 1:04 PM Freeman, Colby (EEC) <colby.freeman@ky.gov> wrote:

Burton,

We will be available from 10-12 tomorrow.

Thanks,

Colby Freeman

Environmental Engineer Technologist I
Chemical Section
Division for Air Quality
300 Sower Blvd
Frankfort, KY 40601

(502) 782 - 1467

From: Burton JOYNER <burton.joyner@amrize.com>
Sent: Wednesday, February 25, 2026 12:48 PM
To: Freeman, Colby (EEC) <colby.freeman@ky.gov>
Cc: Jesse MEGENHARDT <jesse.megenhardt@amrize.com>; Ross, Dakota D (EEC) <dakota.ross@ky.gov>;
jeuler@decaenvironmental.com <jeuler@decaenvironmental.com>; Justin SMITH
<justin.smith2@amrize.com>; Harley, Brian (EEC) <Brian.Harley@ky.gov>
Subject: Re: Notice of Deficiency for AI 71732

Hi Colby,

Would the DAQ PRB be agreeable to a call to review the DEP7007J form with Amrize's team? We have some questions and feel it would benefit us to talk it through to make sure we get you the information you need to issue the conditional permit. If so, I can set something up for tomorrow or Friday.

Thanks,

Burton

On Mon, Feb 23, 2026 at 2:41 PM Burton JOYNER <burton.joyner@amrize.com> wrote:

Hi Colby,

Please forgive my delay in reply. I have been consumed with environmental reporting for all of my locations. I do intend to fill out the requested form this week which should provide you with all the information you need. I will get it to you as soon as I can.

Thanks for your patience.

Burton

On Mon, Feb 23, 2026 at 2:04 PM Freeman, Colby (EEC) <colby.freeman@ky.gov> wrote:

Jesse,

I am following up on the tank emission estimate request below. The Division has determined the pentane storage vessel, as it currently stands and is operated by Amrize, is subject to 40 CFR 60, Subpart Kb. We plan to issue the draft renewal permit with the vessel listed in Section B of the permit along with all of the compliance options and applicable requirements of Subpart Kb. Tank information and emission estimates are necessary to declare the application complete and proceed with issuance of the permit. *Please provide this information as soon as possible, but no later than March 2, 2026.*

If Amrize believes the proposed method of compliance will exempt the tank from the requirements of Subpart Kb pursuant to the pressure vessel exemption at 40 CFR 60.110b(d)(2), this would need to be incorporated into the permit as a preclusion of Subpart Kb. After implementing the change, Amrize would need to submit a significant revision application. The Division would likely include monitoring and recordkeeping requirements to demonstrate the

vessel is designed to operate in excess of 204.9 kPa and without emissions to the atmosphere, including during tank filling operations.

Thanks,

Colby Freeman

Environmental Engineer Technologist I
Chemical Section
Division for Air Quality
[300 Sower Blvd](#)
[Frankfort, KY 40601](#)
(502) 782 - 1467

From: Ross, Dakota D (EEC) <dakota.ross@ky.gov>
Sent: Monday, February 16, 2026 10:14 AM
To: Jesse MEGENHARDT <jesse.megenhardt@amrize.com>; Freeman, Colby (EEC) <colby.freeman@ky.gov>
Cc: jeuler@decaenvironmental.com <jeuler@decaenvironmental.com>; Justin SMITH <justin.smith2@amrize.com>; Burton JOYNER <burton.joyner@amrize.com>; Harley, Brian (EEC) <Brian.Harley@ky.gov>
Subject: RE: Notice of Deficiency for AI 71732

Thank you Jesse,

The Division will review and follow up if we have any questions.

In the meantime could you please provide a DEP 7007J form (<https://eec.ky.gov/Environmental-Protection/Air/Pages/Air-Permitting-Forms-and-Information.aspx>) for the tank and potential emission estimates for both how the tank is currently operating and how the tank will operate after the change using AP-42 Chapter 7.1 methodology/ EPAs Tanks 5.1 software.

Thanks,

Dakota Ross, P.E.

Environmental Engineer
Permit Review Branch
Division for Air Quality

[300 Sower Blvd](#)

[Frankfort, KY 40601](#)

(502) 782 - 6479

From: Jesse MEGENHARDT <jesse.megenhardt@amrize.com>
Sent: Friday, February 13, 2026 10:09 AM
To: Freeman, Colby (EEC) <colby.freeman@ky.gov>
Cc: jeuler@decaenvironmental.com; Justin SMITH <justin.smith2@amrize.com>; Burton JOYNER <burton.joyner@amrize.com>; Ross, Dakota D (EEC) <dakota.ross@ky.gov>; Harley, Brian (EEC) <Brian.Harley@ky.gov>
Subject: Re: Notice of Deficiency for AI 71732

****CAUTION** PDF attachments may contain links to malicious sites. Please contact the COT Service Desk ServiceCorrespondence@ky.gov for any assistance.**

Dear Colby,

Please find attached our proposed solution and implementation plan to address the applicability of 40 CFR, Subpart Kb and the Notice of Deficiency of AL 71732.

Kindly acknowledge the receipt of this email. If you have any questions or concerns please do not hesitate to contact me.

Best Regards,

JESSE MEGENHARDT

Sr. Plant Manager

jesse.megenhardt@amrize.com

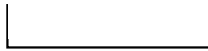

Amrize

[8170 Holton Drive, Florence, KY, USA, Florence, United States, 41042](#)

T: 41042, M: 5025250774

[Amrize](#) | [LinkedIn](#) | [Facebook](#)

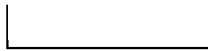

This email is confidential and intended only for the use of the above named addressee. If you have received this email in error, please delete it immediately and notify us by email or telephone.

On Fri, Jan 9, 2026 at 10:29 AM Freeman, Colby (EEC) <colby.freeman@ky.gov> wrote:

Jesse,

The Division has received your response.

Thanks,

Colby Freeman

Environmental Engineer Technologist I

Chemical Section

Division for Air Quality

[300 Sower Blvd](#)

[Frankfort, KY 40601](#)

(502) 782 - 1467

From: Jesse MEGENHARDT <jesse.megenhardt@amrize.com>
Sent: Friday, January 9, 2026 10:13 AM
To: Freeman, Colby (EEC) <colby.freeman@ky.gov>
Cc: jeuler@decaenvironmental.com <jeuler@decaenvironmental.com>; Justin SMITH <justin.smith2@amrize.com>; Burton JOYNER <burton.joyner@amrize.com>; Ross, Dakota D (EEC) <dakota.ross@ky.gov>; Harley, Brian (EEC) <Brian.Harley@ky.gov>
Subject: Re: Notice of Deficiency for AI 71732

****CAUTION** PDF attachments may contain links to malicious sites. Please contact the COT Service Desk ServiceCorrespondence@ky.gov for any assistance.**

Dear Colby,

Please find the attached response regarding the potential applicability of 40 CFR 60, Subpart Kb and the Notice of Deficiency for AI 71732.

Kindly acknowledge receipt of this email.

Best Regards,

JESSE MEGENHARDT

Sr. Plant Manager

jesse.megenhardt@amrize.com



Amrize

[8170 Holton Drive, Florence, KY, USA, Florence, United States, 41042](https://www.amrize.com)

T: 41042, M: 5025250774

[Amrize](#) | [LinkedIn](#) | [Facebook](#)

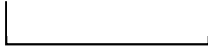

This email is confidential and intended only for the use of the above named addressee. If you have received this email in error, please delete it immediately and notify us by email or telephone.

On Wed, Dec 10, 2025 at 7:55 AM Freeman, Colby (EEC) <colby.freeman@ky.gov> wrote:

Good morning,

Attached is the first Notice of Deficiency for the Conditional Major renewal application for Amrize Building Envelope LLC. This serves as your official copy and a paper copy will not be sent. We request that you submit the information as soon as possible, but in no case later than January 9, 2026.

Please feel free to contact me if you have any questions or need additional clarification.

Thanks,

Colby Freeman

Environmental Engineer Technologist I

Chemical Section

Division for Air Quality

[300 Sower Blvd](#)

[Frankfort, KY 40601](#)

(502) 782 - 1467

Routine Losses Report for TANKS 5.2

Storage Tank Emissions Calculation Application

Version 5.2

(released December 2025)

**U.S. Environmental Protection Agency
Office of Clean Air Programs
Natural Resources Division
Emissions Data and Assessment Branch
Research Triangle Park, NC 27711**

Report Contents

Accumulated Annual Routine Losses for All Tanks	3
Accumulated Monthly Routine Losses for All Tanks	4
For each tank and all tanks combined:	
• Standing Losses	
• Rim Seal Losses	
• Deck Seam Losses	
• Deck Fitting Losses	
• Working Losses	
• Total Routine Losses	
For each tank:	
• Tank Characteristics and Meteorological Location by Tank	
• Tank Contents by Tank	
• Tank Calculations by Tank	
• Fixed Roof Tanks	
• Routine Losses by Tank	
Appendices	
Custom Organic Liquids	11
Custom Petroleum Liquids	12
Custom Mixtures	14
Custom Meteorological Locations	15

Accumulated Annual Routine Losses for All Tanks

Tank ID	Standing Losses	Working Losses	Total Losses
FLO TK-01 - (Pentane Tank)	0	33,637.3449	33,637.3449
Total	0	33,637.3449	33,637.3449

Accumulated Monthly Routine Losses for All Tanks

Standing Losses

Tank ID	Chemical	Jan	Feb	Mar	Apr	May	Jun	Jul	Aug	Sep	Oct	Nov	Dec	Annual
FLO TK-01 - (Pentane Tank)	Isopentane / Acetone Mixture	0	0	0	0	0	0	0	0	0	0	0	0	0

Working Losses

Tank ID	Chemical	Jan	Feb	Mar	Apr	May	Jun	Jul	Aug	Sep	Oct	Nov	Dec	Annual
FLO TK-01 - (Pentane Tank)	Isopentane / Acetone Mixture	1,924.3676	2,063.3335	2,438.5579	2,906.2112	3,234.8285	3,421.6278	3,436.6454	3,437.8185	3,332.1446	2,932.9740	2,461.2332	2,047.6027	33,637.3449

Total Losses

Tank ID	Chemical	Jan	Feb	Mar	Apr	May	Jun	Jul	Aug	Sep	Oct	Nov	Dec	Annual
FLO TK-01 - (Pentane Tank)	Isopentane / Acetone Mixture	1,924.3676	2,063.3335	2,438.5579	2,906.2112	3,234.8285	3,421.6278	3,436.6454	3,437.8185	3,332.1446	2,932.9740	2,461.2332	2,047.6027	33,637.3449

Tank Characteristics and Meteorological Location by Tank

Identification

Tank ID	FLO TK-01 - (Pentane Tank)
Tank Type	Horizontal Fixed Roof Tank
Tank Description	80/20 Isopentane/Acetone Blend Storage Tank
City	Florence
State	Kentucky
Company	Amrize
Meteorological Location	Cincinnati, KY

Tank Characteristics

Shell Length (ft)	58
Shell Diameter (ft)	10
Maximum Liquid Height (ft)	9
Minimum Liquid Height (ft)	1
Vapor Space Pressure at Normal Operating Conditions (psig)	5
Is Tank Insulated or Underground?	Not Insulated and Not Underground
Liquid Bulk Temperature Calculation Method	AP-42 Calculation

Shell Characteristics

Shell Color/Shade	White
Shell Condition	Average

Breather Vent Settings

Vacuum Setting (psig)	-0.125
Pressure Setting (psig)	14.900

Control Device Settings

Is Tank Equipped with a Control Device?	No Control Device
---	-------------------

Tank Contents by Tank

Tank Contents Input Summary

Tank ID	FLO TK-01 - (Pentane Tank)
Input Type	Annual
Chemical Category of Liquid	Custom Organic Mixtures
Sum of Increases in Liquid Level Method	AP-42 Calculation
Working Loss Turnover Factor Method	AP-42 Calculation

Annual Contents

Mixture Name	Speciation Option	Components	Throughput (gal/yr)
Isopentane / Acetone Mixture	Partial Speciation	Acetone, Isopentane: (2-methyl butane)	4963067

Tank Calculations by Tank -- Fixed Roof

Tank ID: FLO TK-01 - (Pentane Tank)

Annual Calculations

Chemical: Isopentane / Acetone Mixture

Annual Vapor Space Volume (cu ft)	2,277.6547
Annual Avg. Vented Vapor Saturation Factor	0.3966
Vapor Space Outage (ft)	3.9270
Shell Radius (ft)	5
Annual Stock Vapor Density (lb/cu ft)	0.1002
Annual Avg. Vapor Molecular Weight (lb/lb-mole)	71.1537
Annual Avg. Vapor Pressure at Avg. Liquid Surface Temp. (psia)	7.8939
Annual Avg. Liquid Surface Temp. (°R)	515.9834
Annual Avg. Ambient Temp. (°R)	513.8408
Annual Avg. Liquid Bulk Temp. (°R)	494.4353
Tank Paint Solar Absorptance (Shell)	0.2500
Annual Avg. Vapor Space Expansion Factor	0
Annual Vapor Temp. Range (°R)	18.7908
Annual Vapor Pressure Range (psia)	1.6624
Breather Vent Pressure Setting Range (psia)	15.0250
Annual Avg. Vapor Pressure at Min Liquid Surface Temp. (psia)	7.0978
Annual Avg. Vapor Pressure at Max Liquid Surface Temp. (psia)	8.7602
Annual Avg. Min. Liquid Surface Temp. (°R)	511.2857
Annual Avg. Max. Liquid Surface Temp. (°R)	520.6811
Annual Avg. Ambient Temp. Range (°R)	17.8417
Annual Throughput (gal)	4963067
Annual Turnovers	11.9145
Annual Sum of Increases in Liquid Level (ft/yr)	1,143.7873
Working Loss Turnover Factor	1
Working Loss Product Factor	1

Tank ID: FLO TK-01 - (Pentane Tank)

Monthly Calculations

Chemical: Isopentane / Acetone Mixture

Calculation	Jan	Feb	Mar	Apr	May	Jun	Jul	Aug	Sep	Oct	Nov	Dec
Vented Vapor Saturation Factor	0.5284	0.5063	0.4511	0.3875	0.3409	0.3015	0.2875	0.2905	0.3245	0.3842	0.4482	0.5089
Stock Vapor Density (lb/cu ft)	0.0579	0.0627	0.0767	0.0973	0.1167	0.1375	0.1461	0.1442	0.1249	0.0986	0.0776	0.0621
Vapor Molecular Weight (lb/lb-mole)	71.2553	71.2400	71.2005	71.1515	71.1118	71.0748	71.0607	71.0638	71.0969	71.1488	71.1984	71.2418
Vapor Pressure at Avg. Liquid Surface Temp. (psia)	4.2877	4.6850	5.8472	7.5940	9.2901	11.1321	11.9046	11.7320	10.0013	7.7004	5.9159	4.6363
Avg. Liquid Surface Temp. (°R)	491.6601	495.3344	504.8039	516.5244	525.9994	534.8452	538.2129	537.4756	529.5663	517.1659	505.3148	494.8979
Avg. Ambient Temp. (°R)	490.7200	493.9200	502.8200	513.9200	522.9700	531.5200	534.9200	534.4700	527.1200	515.4200	504.2200	494.0700
Vapor Space Expansion Factor	0	0	0	0	0	0	0	0	0	0	0	0
Vapor Temp. Range (°R)	12.9150	15.4300	18.5050	21.5900	22.3500	22.8700	22.4950	22.0000	21.2650	18.9250	14.9100	12.2350
Vapor Pressure Range (psia)	0.6740	0.8650	1.2398	1.7826	2.1657	2.5565	2.6508	2.5628	2.1842	1.5796	1.0080	0.6800
Vapor Pressure at Min Liquid Surface Temp. (psia)	3.9614	4.2686	5.2536	6.7442	8.2572	9.9116	10.6371	10.5056	8.9563	6.9428	5.4291	4.3064
Vapor Pressure at Max Liquid Surface Temp. (psia)	4.6353	5.1336	6.4934	8.5268	10.4229	12.4681	13.2880	13.0684	11.1405	8.5224	6.4371	4.9864
Min. Liquid Surface Temp. (°R)	488.4314	491.4769	500.1777	511.1269	520.4119	529.1277	532.5892	531.9756	524.2501	512.4347	501.5873	491.8391
Max. Liquid Surface Temp. (°R)	494.8889	499.1919	509.4302	521.9219	531.5869	540.5627	543.8367	542.9756	534.8826	521.8972	509.0423	497.9566
Ambient Temp. Range (°R)	14.5000	16.1000	18.1000	19.9000	19.2000	18.7000	18.3000	18.8000	20.1000	19.7000	16.7000	14
Throughput (gal/mo)	413,588.9167	413,588.9167	413,588.9167	413,588.9167	413,588.9167	413,588.9167	413,588.9167	413,588.9167	413,588.9167	413,588.9167	413,588.9167	413,588.9167
Sum of Increases in Liquid Level (ft/mo)	95.3156	95.3156	95.3156	95.3156	95.3156	95.3156	95.3156	95.3156	95.3156	95.3156	95.3156	95.3156
Working Loss Product Factor	1	1	1	1	1	1	1	1	1	1	1	1

Supplemental Non-Monthly Data

Vapor Space Volume (cu ft)	2,277.6547
Effective Diameter (ft)	27.1750
Vapor Space Outage (ft)	3.9270
Liquid Bulk Temp. (°R)	494.4353
Tank Paint Solar Absorptance (Shell)	0.2500
Breather Vent Pressure Setting Range (psia)	15.0250
Turnovers	11.9145
Working Loss Turnover Factor	1

Routine Losses by Tank

Tank ID: FLO TK-01 - (Pentane Tank)

Annual Routine Losses

Chemical	Standing Losses	Working Losses	Total Losses
Isopentane / Acetone Mixture	0	33,637.3449	33,637.3449

Total Annual Component Losses

Acetone	1,971.7666
Isopentane: (2-methyl butane)	31,665.5783

Tank ID: FLO TK-01 - (Pentane Tank)

Monthly Routine Losses

Chemical: Isopentane / Acetone Mixture

Loss Type	Jan	Feb	Mar	Apr	May	Jun	Jul	Aug	Sep	Oct	Nov	Dec
Standing Losses	0	0	0	0	0	0	0	0	0	0	0	0
Working Losses	1,924.3676	2,063.3335	2,438.5579	2,906.2112	3,234.8285	3,421.6278	3,436.6454	3,437.8185	3,332.1446	2,932.9740	2,461.2332	2,047.6027
Total Losses	1,924.3676	2,063.3335	2,438.5579	2,906.2112	3,234.8285	3,421.6278	3,436.6454	3,437.8185	3,332.1446	2,932.9740	2,461.2332	2,047.6027

Total Monthly Component Losses

Component	Jan	Feb	Mar	Apr	May	Jun	Jul	Aug	Sep	Oct	Nov	Dec
Acetone	99.7465	108.7992	134.2364	168.3506	194.9407	213.6687	217.4649	216.9130	203.7380	170.3641	135.7931	107.7514
Isopentane: (2-methyl butane)	1,824.6212	1,954.5344	2,304.3215	2,737.8606	3,039.8878	3,207.9591	3,219.1806	3,220.9054	3,128.4065	2,762.6098	2,325.4402	1,939.8512

Custom Organic Liquids

Chemical Name	Molecular Weight	Liquid Density (lb/gal)	Antoine's Equation Constant A	Antoine's Equation Constant B (deg C)	Antoine's Equation Constant C (deg C)
---------------	------------------	-------------------------	-------------------------------	---------------------------------------	---------------------------------------

Custom Petroleum Liquids

Chemical Name	Vapor Molecular Weight (lb/lb-mol)	Liquid Molecular Weight (lb/lb-mol)	Liquid Density (lb/gal)	Vapor Pressure Equation Constant A	Vapor Pressure Equation Constant B (*R)
---------------	------------------------------------	-------------------------------------	-------------------------	------------------------------------	---

Mole Fractions

Petroleum Liquid Name	Component Chemical Name	Component Mole Fraction Type	Component Mole Fraction
-----------------------	-------------------------	------------------------------	-------------------------

Custom Mixtures

Mixture Name	Component Chemical Name	Component Liquid Mole Fraction
Isopentane / Acetone Mixture		
	Acetone	0.2
	Isopentane: (2-methyl butane)	0.8

Custom Meteorological Locations

Location Name	Month	Avg. Max. Ambient Temp. (deg F)	Avg. Min. Ambient Temp. (deg F)	Avg. Wind Speed (mph)	Avg. Daily Total Insolation Factor (Btu/ft2/day)	Avg. Atmospheric Pressure (psi)
---------------	-------	---------------------------------	---------------------------------	-----------------------	--	---------------------------------

Routine Losses Report for TANKS 5.2

Storage Tank Emissions Calculation Application

Version 5.2

(released December 2025)

**U.S. Environmental Protection Agency
Office of Clean Air Programs
Natural Resources Division
Emissions Data and Assessment Branch
Research Triangle Park, NC 27711**

Report Contents

Accumulated Annual Routine Losses for All Tanks	3
Accumulated Monthly Routine Losses for All Tanks	4
For each tank and all tanks combined:	
• Standing Losses	
• Rim Seal Losses	
• Deck Seam Losses	
• Deck Fitting Losses	
• Working Losses	
• Total Routine Losses	
For each tank:	
• Tank Characteristics and Meteorological Location by Tank	
• Tank Contents by Tank	
• Tank Calculations by Tank	
• Fixed Roof Tanks	
• Routine Losses by Tank	
Appendices	
Custom Organic Liquids	11
Custom Petroleum Liquids	12
Custom Mixtures	14
Custom Meteorological Locations	15

Accumulated Annual Routine Losses for All Tanks

Tank ID	Standing Losses	Working Losses	Total Losses
FLO TK-01 - (Pentane Tank)	0	1,681.8672	1,681.8672
Total	0	1,681.8672	1,681.8672

Accumulated Monthly Routine Losses for All Tanks

Standing Losses

Tank ID	Chemical	Jan	Feb	Mar	Apr	May	Jun	Jul	Aug	Sep	Oct	Nov	Dec	Annual
FLO TK-01 - (Pentane Tank)	Isopentane / Acetone Mixture	0	0	0	0	0	0	0	0	0	0	0	0	0

Working Losses

Tank ID	Chemical	Jan	Feb	Mar	Apr	May	Jun	Jul	Aug	Sep	Oct	Nov	Dec	Annual
FLO TK-01 - (Pentane Tank)	Isopentane / Acetone Mixture	96.2184	103.1667	121.9279	145.3106	161.7414	171.0814	171.8323	171.8909	166.6072	146.6487	123.0617	102.3801	1,681.8672

Total Losses

Tank ID	Chemical	Jan	Feb	Mar	Apr	May	Jun	Jul	Aug	Sep	Oct	Nov	Dec	Annual
FLO TK-01 - (Pentane Tank)	Isopentane / Acetone Mixture	96.2184	103.1667	121.9279	145.3106	161.7414	171.0814	171.8323	171.8909	166.6072	146.6487	123.0617	102.3801	1,681.8672

Tank Characteristics and Meteorological Location by Tank

Identification

Tank ID	FLO TK-01 - (Pentane Tank)
Tank Type	Horizontal Fixed Roof Tank
Tank Description	80/20 Isopentane/Acetone Blend Storage Tank
City	Florence
State	Kentucky
Company	Amrize
Meteorological Location	Cincinnati, KY

Tank Characteristics

Shell Length (ft)	58
Shell Diameter (ft)	10
Maximum Liquid Height (ft)	9
Minimum Liquid Height (ft)	1
Vapor Space Pressure at Normal Operating Conditions (psig)	5
Is Tank Insulated or Underground?	Not Insulated and Not Underground
Liquid Bulk Temperature Calculation Method	AP-42 Calculation

Shell Characteristics

Shell Color/Shade	White
Shell Condition	Average

Breather Vent Settings

Vacuum Setting (psig)	-0.125
Pressure Setting (psig)	14.900

Control Device Settings

Is Tank Equipped with a Control Device?	Control Device
Control Device Type Efficiency	95

Tank Contents by Tank

Tank Contents Input Summary

Tank ID	FLO TK-01 - (Pentane Tank)
Input Type	Annual
Chemical Category of Liquid	Custom Organic Mixtures
Sum of Increases in Liquid Level Method	AP-42 Calculation
Working Loss Turnover Factor Method	AP-42 Calculation

Annual Contents

Mixture Name	Speciation Option	Components	Throughput (gal/yr)
Isopentane / Acetone Mixture	Partial Speciation	Acetone, Isopentane: (2-methyl butane)	4963067

Tank Calculations by Tank -- Fixed Roof

Tank ID: FLO TK-01 - (Pentane Tank)

Annual Calculations

Chemical: Isopentane / Acetone Mixture

Annual Vapor Space Volume (cu ft)	2,277.6547
Annual Avg. Vented Vapor Saturation Factor	0.3966
Vapor Space Outage (ft)	3.9270
Shell Radius (ft)	5
Annual Stock Vapor Density (lb/cu ft)	0.1002
Annual Avg. Vapor Molecular Weight (lb/lb-mole)	71.1537
Annual Avg. Vapor Pressure at Avg. Liquid Surface Temp. (psia)	7.8939
Annual Avg. Liquid Surface Temp. (°R)	515.9834
Annual Avg. Ambient Temp. (°R)	513.8408
Annual Avg. Liquid Bulk Temp. (°R)	494.4353
Tank Paint Solar Absorptance (Shell)	0.2500
Annual Avg. Vapor Space Expansion Factor	0
Annual Vapor Temp. Range (°R)	18.7908
Annual Vapor Pressure Range (psia)	1.6624
Breather Vent Pressure Setting Range (psia)	15.0250
Annual Avg. Vapor Pressure at Min Liquid Surface Temp. (psia)	7.0978
Annual Avg. Vapor Pressure at Max Liquid Surface Temp. (psia)	8.7602
Annual Avg. Min. Liquid Surface Temp. (°R)	511.2857
Annual Avg. Max. Liquid Surface Temp. (°R)	520.6811
Annual Avg. Ambient Temp. Range (°R)	17.8417
Annual Throughput (gal)	4963067
Annual Turnovers	11.9145
Annual Sum of Increases in Liquid Level (ft/yr)	1,143.7873
Working Loss Turnover Factor	1
Working Loss Product Factor	1

Tank ID: FLO TK-01 - (Pentane Tank)

Monthly Calculations

Chemical: Isopentane / Acetone Mixture

Calculation	Jan	Feb	Mar	Apr	May	Jun	Jul	Aug	Sep	Oct	Nov	Dec
Vented Vapor Saturation Factor	0.5284	0.5063	0.4511	0.3875	0.3409	0.3015	0.2875	0.2905	0.3245	0.3842	0.4482	0.5089
Stock Vapor Density (lb/cu ft)	0.0579	0.0627	0.0767	0.0973	0.1167	0.1375	0.1461	0.1442	0.1249	0.0986	0.0776	0.0621
Vapor Molecular Weight (lb/lb-mole)	71.2553	71.2400	71.2005	71.1515	71.1118	71.0748	71.0607	71.0638	71.0969	71.1488	71.1984	71.2418
Vapor Pressure at Avg. Liquid Surface Temp. (psia)	4.2877	4.6850	5.8472	7.5940	9.2901	11.1321	11.9046	11.7320	10.0013	7.7004	5.9159	4.6363
Avg. Liquid Surface Temp. (°R)	491.6601	495.3344	504.8039	516.5244	525.9994	534.8452	538.2129	537.4756	529.5663	517.1659	505.3148	494.8979
Avg. Ambient Temp. (°R)	490.7200	493.9200	502.8200	513.9200	522.9700	531.5200	534.9200	534.4700	527.1200	515.4200	504.2200	494.0700
Vapor Space Expansion Factor	0	0	0	0	0	0	0	0	0	0	0	0
Vapor Temp. Range (°R)	12.9150	15.4300	18.5050	21.5900	22.3500	22.8700	22.4950	22.0000	21.2650	18.9250	14.9100	12.2350
Vapor Pressure Range (psia)	0.6740	0.8650	1.2398	1.7826	2.1657	2.5565	2.6508	2.5628	2.1842	1.5796	1.0080	0.6800
Vapor Pressure at Min Liquid Surface Temp. (psia)	3.9614	4.2686	5.2536	6.7442	8.2572	9.9116	10.6371	10.5056	8.9563	6.9428	5.4291	4.3064
Vapor Pressure at Max Liquid Surface Temp. (psia)	4.6353	5.1336	6.4934	8.5268	10.4229	12.4681	13.2880	13.0684	11.1405	8.5224	6.4371	4.9864
Min. Liquid Surface Temp. (°R)	488.4314	491.4769	500.1777	511.1269	520.4119	529.1277	532.5892	531.9756	524.2501	512.4347	501.5873	491.8391
Max. Liquid Surface Temp. (°R)	494.8889	499.1919	509.4302	521.9219	531.5869	540.5627	543.8367	542.9756	534.8826	521.8972	509.0423	497.9566
Ambient Temp. Range (°R)	14.5000	16.1000	18.1000	19.9000	19.2000	18.7000	18.3000	18.8000	20.1000	19.7000	16.7000	14
Throughput (gal/mo)	413,588.9167	413,588.9167	413,588.9167	413,588.9167	413,588.9167	413,588.9167	413,588.9167	413,588.9167	413,588.9167	413,588.9167	413,588.9167	413,588.9167
Sum of Increases in Liquid Level (ft/mo)	95.3156	95.3156	95.3156	95.3156	95.3156	95.3156	95.3156	95.3156	95.3156	95.3156	95.3156	95.3156
Working Loss Product Factor	1	1	1	1	1	1	1	1	1	1	1	1

Supplemental Non-Monthly Data

Vapor Space Volume (cu ft)	2,277.6547
Effective Diameter (ft)	27.1750
Vapor Space Outage (ft)	3.9270
Liquid Bulk Temp. (°R)	494.4353
Tank Paint Solar Absorptance (Shell)	0.2500
Breather Vent Pressure Setting Range (psia)	15.0250
Turnovers	11.9145
Working Loss Turnover Factor	1

Routine Losses by Tank

Tank ID: FLO TK-01 - (Pentane Tank)

Annual Routine Losses

Chemical	Standing Losses	Working Losses	Total Losses
Isopentane / Acetone Mixture	0	1,681.8672	1,681.8672

Total Annual Component Losses

Acetone	98.5883
Isopentane: (2-methyl butane)	1,583.2789

Tank ID: FLO TK-01 - (Pentane Tank)

Monthly Routine Losses

Chemical: Isopentane / Acetone Mixture

Loss Type	Jan	Feb	Mar	Apr	May	Jun	Jul	Aug	Sep	Oct	Nov	Dec
Standing Losses	0	0	0	0	0	0	0	0	0	0	0	0
Working Losses	96.2184	103.1667	121.9279	145.3106	161.7414	171.0814	171.8323	171.8909	166.6072	146.6487	123.0617	102.3801
Total Losses	96.2184	103.1667	121.9279	145.3106	161.7414	171.0814	171.8323	171.8909	166.6072	146.6487	123.0617	102.3801

Total Monthly Component Losses

Component	Jan	Feb	Mar	Apr	May	Jun	Jul	Aug	Sep	Oct	Nov	Dec
Acetone	4.9873	5.4400	6.7118	8.4175	9.7470	10.6834	10.8732	10.8457	10.1869	8.5182	6.7897	5.3876
Isopentane: (2-methyl butane)	91.2311	97.7267	115.2161	136.8930	151.9944	160.3980	160.9590	161.0453	156.4203	138.1305	116.2720	96.9926

Custom Organic Liquids

Chemical Name	Molecular Weight	Liquid Density (lb/gal)	Antoine's Equation Constant A	Antoine's Equation Constant B (deg C)	Antoine's Equation Constant C (deg C)
---------------	------------------	-------------------------	-------------------------------	---------------------------------------	---------------------------------------

Custom Petroleum Liquids

Chemical Name	Vapor Molecular Weight (lb/lb-mol)	Liquid Molecular Weight (lb/lb-mol)	Liquid Density (lb/gal)	Vapor Pressure Equation Constant A	Vapor Pressure Equation Constant B (*R)
---------------	------------------------------------	-------------------------------------	-------------------------	------------------------------------	---

Mole Fractions

Petroleum Liquid Name	Component Chemical Name	Component Mole Fraction Type	Component Mole Fraction
-----------------------	-------------------------	------------------------------	-------------------------

Custom Mixtures

Mixture Name	Component Chemical Name	Component Liquid Mole Fraction
Isopentane / Acetone Mixture		
	Acetone	0.2
	Isopentane: (2-methyl butane)	0.8

Custom Meteorological Locations

Location Name	Month	Avg. Max. Ambient Temp. (deg F)	Avg. Min. Ambient Temp. (deg F)	Avg. Wind Speed (mph)	Avg. Daily Total Insolation Factor (Btu/ft ² /day)	Avg. Atmospheric Pressure (psi)
---------------	-------	---------------------------------	---------------------------------	-----------------------	---	---------------------------------

Section 1. Substance name and company identification**Product identifier**Common name **Isopentane and Acetone Blend**Synonyms **Isopentane and Acetone Blend****1.1 Relevant identified uses of the substances or mixture and of the company/undertaking**

Solvent, blowing agent for polystyrene, chemical intermediate

1.2 Details of the supplier of the safety data sheet

Manufacturer Trecora Hydrocarbons, LLC
7752 FM 418
Silsbee, Texas 77656
USA
Tel: + 1 409-385-8300
E mail: Hydrocarbons.Service@trecora.com

EU Only Representative TSGE
Concordia House, St James Business Park,
Grimbald Crag Court, Knaresborough,
North Yorkshire, HG5 8QB,
United Kingdom
Tel: +44 (0) 1423 799 633
Fax: +44 (0) 1423 797 804

1.3 Emergency telephone number

In case of emergency Tel. +1 703 527 3887 (CHEMTREC)

Section 2. Hazards Identification**2.1 GHS Classification**

Flammable liquids, Category 1
Eye irritation, Category 2B
Specific target organ systematic toxicity-single exposure, Category 3
Aspiration hazard, Category 1
Hazardous to the aquatic environment, chronic toxicity, Category 2

2.2 GHS Label elements**Pictograms:****Signal Word:** Danger

Hazard Statements

H224	Extremely flammable liquid and vapor
H304	May be fatal if swallowed and enters airways
H319	Causes serious eye irritation.
H336	May cause drowsiness or dizziness.
H411	Toxic to aquatic life with long lasting effects.

Precautionary statements

P210	Keep away from heat, hot surfaces, sparks, open flames, and other ignition sources. No smoking.
P240	Ground and bond container and receiving equipment.
P241	Use explosion-proof electrical/ ventilating/ lighting/ equipment.
P242	Use non-sparking tools.
P243	Take action to prevent static discharge.
P261	Avoid breathing dust/fume/gas/mist/vapours/spray.
P264	Wash hands thoroughly after handling
P271	Use only outdoors or in a well-ventilated area.
P273	Avoid release to the environment.
P280	Wear protective gloves/protective clothing/eye protection/face protection.
P301+P316	IF SWALLOWED: Get emergency medical help immediately, call a POISON CENTER or doctor/physician.
P331	DO NOT induce vomiting
P303+P361+P353	IF ON SKIN (or hair): Remove/Take off immediately all contaminated clothing. Rinse skin with water/shower.
P304+P340	IF INHALED: Remove person to fresh air and keep comfortable for breathing.
P305 +P351 + P338	IF IN EYES: Rinse cautiously with water for several minutes. Remove contact lenses, if present and easy to do. Continue rinsing.
P319	Get medical help if you feel unwell
P337 + P317	if eye irritation persists: Get medical help.
P370+P378	in case of fire: Use foam, carbon dioxide or dry powder for extinction.
P391	Collect Spillage
P403+P233	Store in a well-ventilated place. Keep container tightly closed.
P403+P235	Store in a well-ventilated place. Keep cool.
P405	Store locked up
P501	Dispose of contents/container in accordance with local/regional/national/international regulation.

Section 3. Composition

Name	EC No	CAS No	Concentration
Isopentane	201-142-8	78-78-4	1-99 %
Acetone	200-662-2	67-64-1	1-99 %

All concentrations are percent by weight unless ingredient is a gas. Gas concentrations are in percent by volume.

Section 4. First Aid Measures

4.1 Description of first aid measures

Inhalation

If breathing difficulties, dizziness, or light-headedness occur when working in areas with high vapour concentrations, remove victim to fresh air. If victim experiences continued breathing difficulties, keep patient warm and at rest, and seek medical attention. If breathing stops, begin artificial respiration and seek immediate medical attention.

Skin contact

If this product comes into contact with the skin, wash with soap and water. Seek medical attention if irritation persists. Remove and wash contaminated clothing before re-use.

Accidental eye contact

If this product comes into contact with the eyes, flush with large quantities of water for several minutes, while gently holding the eyelids open. Seek medical attention if irritation persists.

Ingestion

If this product is swallowed, DO NOT INDUCE VOMITING. Give small quantities (<250 ml) of water to drink. Never give anything by mouth to an unconscious person. Seek immediate medical attention

Notes to doctor/physician

Aspiration of solvent may cause chemical pneumonitis.

4.2 Most important symptoms and effects, both acute and delayed

Inhalation: Isopentane and Acetone may cause dizziness and drowsiness if inhaled and high concentrations may result in central nervous system depression, and loss of consciousness.

Ingestion: Symptoms of ingestion may include nausea, vomiting, as well as symptoms of dizziness, drowsiness and central nervous system depression. If vomiting occurs, pentanes may be aspirated into the lungs, with a risk of chemical pneumonitis.

4.3 Indication of any immediate attention and special treatment needed

If ingested or inhaled seek medical attention immediately.

Section 5. Firefighting Measures

5.1 Extinguishing media

Small fires: Use foam, carbon dioxide or dry powder extinguisher.

Large fires: Use foam to extinguish fires. Water spray should not be used, as pentane is lighter than water and may form pools of burning liquid on top of water. Keep adjacent containers cool using water spray.

5.2 Special hazards arising from the substance or mixture

Isopentane and Acetone are extremely flammable. Remove all sources of ignition. Vapours are heavier than air and may travel considerable distances to a source of ignition and flash back. Vapour/air mixtures may be explosive. Electrostatic discharges may cause fire and/or explosion.

5.3 Advice for fire-fighters

Wear positive pressure Self Contained Breathing Apparatus.

Section 6. Accidental Release Measures

6.1 Personal precautions, protective equipment and emergency procedures

Remove all ignition sources and evacuate unnecessary personnel from the area. Ventilate the area if possible. Wear suitable protective clothing including solvent resistant gloves and coveralls. If vapour concentrations are high, respiratory protective equipment may be required. See section 8 for more information.

6.2 Environmental precautions

Prevent entry into sewers and watercourses. If product enters sewers or watercourses, inform the appropriate environmental authorities.

6.3 Method for cleaning up

Small spills: Remove all ignition sources. Use non-sparking hand tools. Take precautions to avoid electrostatic discharge. Absorb spillage in a non-combustible absorbent, e.g. sand or vermiculite, and place in a suitable container for disposal.

Large spills: Remove all ignition sources. Use non-sparking hand tools. Contain spill and cover if possible to reduce evaporation. Transfer to a suitable container by mechanical means. Take precautions to avoid static discharge, e.g. by grounding containers, etc.

6.4 Reference to other sections

Refer to section 8 of SDS for personal protection details.

Section 7. Handling and Storage

7.1 Precautions for safe handling

Avoid contact with skin and eyes. Use only in well ventilated areas. Isopentane and Acetone is extremely flammable. Avoid contact with all ignition sources, including hot surfaces. Take precautions to avoid electrostatic discharges, such as grounding of containers and equipment, and restricting flow rates. Vapours are heavier than air and may accumulate in low lying areas and below ground areas such as ducts and sewers.

7.2 Condition for safe storage, including any incompatibilities

Store in a well ventilated area, away from all ignition sources. If stored in drums, keep out of direct sunlight.

Section 8. Exposure Controls/Personal Protection

8.1 Control parameters

Substance	TWA	STEL	IDLH
Acetone	500 ppm	750 ppm	2500 ppm
Isopentane	600 ppm		1500 ppm

8.2 Exposure controls

Ensure there is sufficient ventilation of the area. The floor of the storage room must be impermeable to prevent the escape of liquids. General mechanical ventilation may be sufficient to keep product vapour concentrations within specified time-weighted TLV ranges. If general ventilation proves inadequate to maintain safe vapour concentrations, supplemental local exhaust may be required. Other special precautions such as respiratory masks or environmental containment devices may be required in extreme cases.

Respiratory protection

Use only in well ventilated area. If high exposure levels are likely, then suitable respiratory protection will be required. Very high vapour concentrations may result in oxygen displacement and self-contained breathing apparatus or airline may be required.

Hand Protection

Wear suitable chemical resistant gloves recommended for use with hydrocarbon solvent. Nitrile gloves may be suitable, but glove manufacturers' specifications should always be checked first. Natural rubber gloves are not suitable. Change gloves in accordance with manufacturer recommendations. If gloves are damaged during use, remove immediately and wash hands before replacing with new gloves.

Eye protection

Wear suitable eye protection, safety glasses or goggles, when handling this product.

Skin protection

Aprons or coveralls made of fire retardant material are recommended. These should be changed after use or if contaminated. Wash before re-use.

Section 9. Physical and Chemical Properties

9.1 Information on basic physical and chemical properties

Note: Unless otherwise stated, values are determined at 20°C (68°F) and 760 mm Hg (1 atm). Data represent typical values and are not intended to be specifications.

Physical State	Liquid
Appearance:	Colorless Liquid
Odor:	Gasoline-like odor
Odor Threshold	Not available
pH:	Not available
Evaporation Rate	Not available
Melting point/freezing point:	256°F/-160°C
Approximate boiling range :	80-100°F/27-38°C
Flash point:	-70°F/-57°C
Auto-ignition Temperature	788°F/402°C
Decomposition Temperature	Not available
Flammability limits in air	
Lower:	1.4 v%
Upper:	8.3 v%
Reid vapor pressure at 100°F:	20.7 psia
Relative vapor density (Air=1.0)	2.6
Density at 60°F:	0.624 kg/l
Solubility in water:	negligible
Partition Coefficient: n-octanol/water:	2.72
Viscosity:	not available

Sources of Information:

1. Company product testing
2. Hawley's Condensed Chemical Dictionary revised by N. Irving Sax and Richard J. Lewis, and
3. CHRIS directory

Section 10. Stability and Reactivity

10.1 Reactivity

Stable under normal conditions.

10.2 Chemical stability

Stable under normal conditions.

10.3 Possibility of hazardous reactions

Hazardous polymerization will not occur.

10.4 Conditions to avoid

Keep away from sources of ignition.

10.5 Incompatible materials

This product is incompatible with strong oxidizing agents, strong acids and bases, and selected amines.

10.6 Hazardous decomposition products

None

Section 11. Toxicological Information

11.1 Information on toxicological effects

Acute Toxicity:

LD₅₀ (Rat, oral) >2000 mg.kg

LC₅₀ (Mouse, inhalation 295 mg/l/2

hour)LC₅₀ (Rat, inhalation) 364

g/m³/4 hour

Harmful when inhaled in high concentrations or ingested. Isopentane and Acetone may cause dizziness and drowsiness if inhaled, and high concentrations may result in central nervous system depression, and loss of consciousness. Symptoms of ingestion may include nausea, vomiting, as well as symptoms of dizziness, drowsiness and central nervous system depression. If vomiting occurs, pentane may be aspirated into the lungs, with a risk of chemical pneumonitis.

Irritation: Isopentane and Acetone can be irritating to the eye, may cause redness.

Corrosivity: Not corrosive

Sensitisation: Not known to be a sensitizer

Repeated dose toxicity: Prolonged or repeated contact of this product will result in defatting of the skin, causing dryness and cracking.

Carcinogenicity: Not expected to be carcinogenic.

Mutagenicity: Not expected to be mutagenic

Toxicity for reproduction: Not expected to be toxic to reproduction.

Route of exposure: Inhalation and ingestion

Symptoms related to the physical, chemical and toxicological characteristics: Isopentane and Acetone may cause dizziness and drowsiness if inhaled and high concentrations may result in central nervous system depression, and loss of consciousness. Symptoms of ingestion may include nausea, vomiting, as well as symptoms of dizziness, drowsiness and central nervous system depression. If vomiting occurs, Pentanes may be aspirated into the lungs, with a risk of chemical pneumonitis.

Section 12. Ecological Information

12.1 Toxicity

EC50 (*Oncorhynchus mykiss*, rainbow trout) 4.26 mg/l (96

hour)EC50 (*Daphnia magna*) 2.7 mg/l (48 hour)

Isopentane and Acetone are classified as toxic to aquatic organisms and likely to cause long term effects in the environment.

12.2 Persistence and degradability

Isopentane and Acetone is readily biodegradable in aquatic systems, however, in view of its high evaporation rate, pentane is expected to volatilize rapidly from water sources into the atmosphere, where it will be degraded by photochemical reaction.

12.3 Bio accumulative potential

No information available

12.4 Mobility in soil

No information available

12.5 Results of PBT and vPvB assessment

No information available

12.6 Other adverse effects

No further details

Section 13. Disposal Considerations

13.1 Waste treatment methods

Recover and recycle product if possible. If recovery and recycling are not possible, n-pentane may be disposed of by incineration.

Please follow all local, regional, and national and international laws.

Section 14. Transport Information

14.1 UN number

1265

14.2 USDOT (United States Department of Transportation) (Domestic)

USDOT Proper Shipping Name: Pentanes

Hazard Classification: 3, Packing Group: 1

Label: Flammable Liquid

Placard: Flammable Liquid

14.3 IMO/IMDG (International Maritime Dangerous Goods) (Water)

IMO Proper Shipping Name: Pentanes Hazard

Classification: 3, Packing Group: 1 Label:

Flammable Liquid

14.4 IATA (International Air Transport Association)

Proper Shipping Name: Pentanes

Hazard Classification: 3, Packing Group: 1

Label: Flammable Liquid

14.5 ADR (Agreement on Dangerous Goods by Road (Europe))

Proper Shipping Name: Pentanes

Hazard Classification: 3, Packing Group: 1,

Environmentally Hazardous

Section 15. Regulatory Information

15.1 Clean Air Act

- This product neither contains nor was it manufactured with any class 1 or class 2 ozone depleting substances.
- Under Section 112 (r), 40 CFR Part 68, the threshold quantity for both n-



Isopentane and Acetone Blend

Safety Data Sheet

According To Federal Register / Vol. 77, No. 58 / Monday, March 26, 2012 / Rules And Regulations And According To The Hazardous Products Regulation (February 11, 2015).

Revision Date: 11/16/2022

Date of Issue: 11/16/2022

Version: 3.0

pentane and isopentane is 10,000 lbs.

15.2 Emergency Planning and Community Right-to-Know Act (EPCRA)

- Section 302- This product does not contain any constituents that are classified as an extremely hazardous substance.
- Section 311/312 (Tier II) - This product is considered a fire hazard and an acute health hazard.
- Section 313- This product contains no toxic chemicals.

15.3 California Office of Environmental Health Hazard Assessment

- Proposition 65- This product contains none of the chemicals which may cause cancer or birth defects as listed in this legislation.

15.4 Coalition of Northeast Governors (CONEG)

- This product contains no lead, mercury, cadmium, or hexavalent chromium.

15.5 New Jersey Right-to-Know

- Isopentane and Acetone both appear on this state's hazardous substance list.

15.6 Pennsylvania Right-to-Know

- Isopentane and Acetone both appear on this state's hazardous substance list.

15.7 Toxic Substance Control Act (TSCA)

- All constituents of this product are listed in TSCA.

15.8 Other Inventories

- The constituents of this product are known to be listed on the following country inventories:

- Canada (DSL)
- Japan (ENCS)
- Australia (AICS)
- Philippines (PICCS)
- China (IECSC)
- Korea (KECI)

Section 16. Other Information

Hazard Ratings:

GHS:

Health: 4
 Flammability: 1
 Reactivity: 5

NFPA:

Health: 1
 Fire: 4
 Reactivity: 0
 Specific Hazard: None

HMIS:

Health: 1
 Flammability: 4
 Reactivity: 0

The above information is believed to be correct as of the date hereof. However no warranty of merchantability fitness for any use or any other warranty is expressed or is to be implied regarding the accuracy of this data, the results to be obtained from the use of the material, or the hazards connected with such use. Since the information contained herein may be applied under conditions beyond our control and with which we may be unfamiliar, and since data made available subsequent to the data hereof may suggest modification of the information, we do not assume responsibility for the results of its use. This information is furnished on the condition that the person receiving it shall make his own determination as to the suitability of the material for his particular purpose and on the condition that he assumes the risk of his use thereof.

WORKING STANDARD APPROVAL CONSIDERATION FORM



New	Drafted by:	<u>L.McSwiney</u>
Revision	Department:	<u>Production</u>
Cancel	Plant:	<u>Florence</u>

<u>Working Standard Number:</u> FWS-390-A-007-005	<u>Title:</u> Pentane Railcar Offload
--	--

ISSUE / REVISION HISTORY

Revision Level	Issue Date	Explanation of Content / Revision	Step(s) / Page(s)
New	N/A		All
001	12/14/2016	Added ECP Tab with Hyperlink to current plan	ECP
002	2/14/2017	Reviewed and correct Step numbers	All
003	2/8/2019	Update with visual for valves to open and close	Normal Setup 1b. and Normal Shutdown
004	3/23/2020	Updated Hook up & Release forms	2
005	8/24/2022	Updated Hook up & Release Forms with New Controlled Document Number	2

Distribution

Location	Copies	Location	Copies

APPROVAL

Name	Position	Approval Date	Initials
Charlie Roberts	Ops Manager	See "Electronic Approvals" Tab	

Referenced Standards

Working Standards	Standard Practice	Others

Paste Electronic Final Approvals Here



Dept: Production
 Drafted by: L.McSwiney
 WS Number: FWS-390-A-007-005
 Rev. Number: 5

Page 1 of 1
 Issue Date: 3/23/2020
 Title: Pentane
 Railcar
 Offload

Steps of
 Duplication,
 WS number
 and Step

See Step Tabs Below for WS

Summary of Operations Step Sheet

Step No		
PPE	Personal Protective Equipment Required	
Safety	Hazards of chemicals used in the process	
Safety	Eye wash and safety showers	
Safety	Safety systems and their functions	
Safety	Safe operating limits for process/equipment	
Safety	Consequences of deviating from normal operating limits	
Safety	Steps required to correct deviations	
Paperwork 1	Certificate of Analysis and Bill of Lading	
Paperwork 2	Pre-offload checklist and railcar release form	
1	Normal process/equipment start up	
2	Normal process/equipment operations	
3	Normal process/equipment shut down	
4	Temporary process/equipment operations	
5	Emergency shutdown of process/equipment	
6	Start up of process/equipment following an emergency shut down	
7	Railcar heating- No Heating up	



EXCEL WORKING STANDARD

Document No.:	FWS-390-A-007-005
Revision Level:	5
Drafted By:	L. McSwiney
Ops Manager	Charlie Roberts
Effective Date:	3/23/2020

OPERATION:	Personal Protective Equipment Required	Safety
<p>The required safety items needed to properly unload a tanker are:</p> <ul style="list-style-type: none">1) Safety Glasses must meet ANSI Z87.1-20032) Chemical Resistant Apron3) Chemical Resistant Gloves4) Face Shield5) Safety Shoes must meet ASTM F-2412-2005		
		

AMRIZE

EXCEL WORKING STANDARD

Document No.:	FWS-390-A-007-005
Revision Level:	5
Drafted By:	L.McSwiney
Ops Manager	Charlie Roberts
Effective Date:	3/23/2020

OPERATION:

ECP

Safety

Before Locking Out equipment used in this working standard, Please reference the TASK SPECIFIC Energy Control Procedure (ECP) located on the equipment or in the maint Shop.

If you have questions or concerns on or about this ECP, please contact our Safety Manager, Safety Co-ordinator, Plant Superintendent, Maint. or Production Supervisor PRIOR to starting the Lockout procedure.

If it becomes necessary to perform maintenance on the Pentane Railcar Offload equipment for any reason, the Pentane Railcar Offload equipment **MUST BE LOCKED OUT.**
FOLLOW THE BELOW ECP

ECP-122 Pentane Railcar Unload



WORKING STANDARD

Document No.:	FWS-390-A-007-005
Revision Level:	5
Drafted By:	L.McSwiney
Oper. Manager:	Charlie Roberts
Effective Date:	3/23/2020

OPERATION:	Hazardous Chemical Used In Process	STEP NUMBER:	4
------------	------------------------------------	--------------	---

Pentane/Acetone Blend is a colorless liquid with a gasoline-like odor.

- a. Flammable
- b. Health Hazard
- c. Dangerous for the Environment
- d. Harmful/Irritant

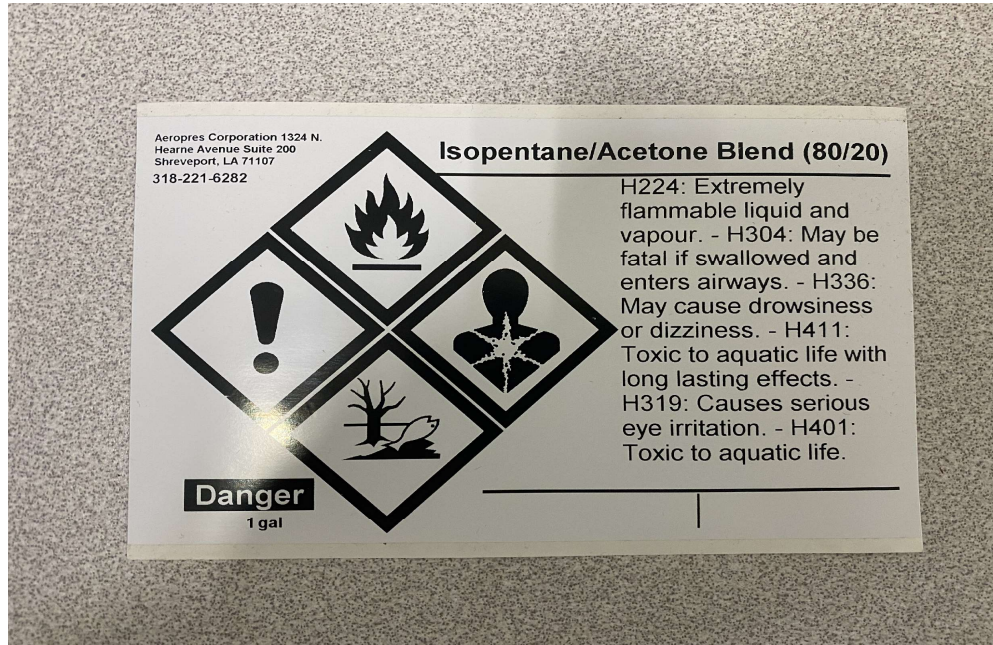

Keep away from heat, sparks, flames, static electricity or other sources of ignition. This product contains EXTREMELY FLAMMABLE LIQUID and VAPORS. Vapor can cause a flash fire . Radios must be turned off and all cell phones and bluetooth devices (smartwatches) must be left inside and not on the unload pad.



EXCEL WORKING STANDARD

Document No.:	FWS-390-A-007-005
Revision Level:	5
Drafted By:	L. McSwiney
Ops Manager	Charlie Roberts
Effective Date:	3/23/2020

OPERATION: **Eye wash and safety showers**

Safety

In case of eye or skin contact with pentane, use emergency eye wash and/or safety shower immediately. Three are located adjacent to the unloading area.

a. Eyewash and safety shower located on exterior wall by pentane railcar hookup.

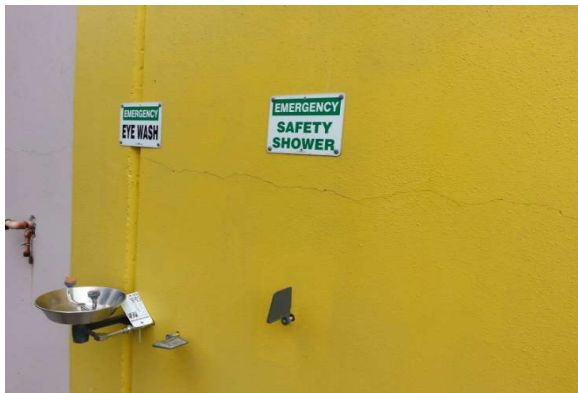

b. Eyewash and safety shower on exterior wall in truck offload area.



c. Eyewash and safety shower located inside by bulk chemical tanks.



EXCEL WORKING STANDARD

Document No.:	FWS-390-A-007-005
Revision Level:	5
Drafted By:	L.McSwiney
Ops Manager	Charlie Roberts
Effective Date:	3/23/2020

OPERATION: Safety systems and their functions	Safety Systems
<p>Numerous safety systems are in place to prevent hazardous spills or other emergencies:</p> <p>To prevent a catastrophic rail accident prior to or during delivery, a warning sign ("Stop - Men at Work") is attached to the rails just ahead of the gravel crossing, approximately fifty feet from the offloading area. Another, identical sign is posted on the rear of the railcar being emptied. At the other end of the gravel crossing, nearer the offloading area, another sign, ("Derail") is attached to the rail, and is comprised of a mechanism intended to derail a runaway train to prevent a collision with any stationary railcars or the building.</p> <p>A sensor on top of the pentane storage tank automatically shuts the system down to prevent the tank being filled beyond capacity. A conservation vent prevents tank over pressurization and vacuum relief. The conservation vent is set up at 14.9 PSI and 2 oz. for pressurization and vacuum relief respectively. (See image, next page)</p> <p>Emergency stop buttons (also called e-stops) are located inside the batcher shack, on both grounding wire posts (by the railcar and at the truck unloading area), on the fence by the pentane tank, and on the exterior of the main building facing the pentane tank.</p> <p>Fire extinguishers are located directly inside the building doors and inside the batcher shack.</p> <p>MSA combustible gas detection alarms are located in the containment area by the pentane storage tank, and inside the building on both sides of the laminator. An alarm sounds if combustible gases reach 15% of the LEL (Lower Explosive Limit), and the system automatically shuts down at 30% of the LEL.</p> <p>Positive indication grounding clamps and wires attached to the railcar conduct static electricity to the ground, preventing an explosion.</p> <p>The pentane storage tank is surrounded by a concrete dike. If any pentane spills, it will be held in the containment area for hazmat cleanup.</p> <p>Emergency eye wash and shower stations are located outside the building by the truck unloading area, by the railcar unloading area, and inside the bulk poly chemical storage tank area.</p>	



EXCEL WORKING STANDARD

Document No.:	FWS-390-A-007-005
Revision Level:	5
Drafted By:	L.McSwiney
Ops Manager	Charlie Roberts
Effective Date:	3/23/2020

OPERATION:	Safe operating limits for process/equipment	Safe Operating Limits
------------	---	-----------------------

Safe operating limits:

Tank storage capacity is approximately 231,000 lbs.

To calculate current volume, take number of gallons from solar gauge, multiply by 5.224 to get number of pounds

of pentane currently in tank. Example: Current volume per solar gauge is 10,680 gallons. $10,680 * 5.224 = 55,792$ lbs currently in tank.

Delivery is 43,640 lbs. $55,792 + 43,640 = 99,432$ lbs. in tank after delivery.

Okay to accept delivery. If delivery plus current volume would exceed storage capacity, notify supervisor.



Overfill sensor on top of pentane storage tank

Conservation vent

Document No.:	FWS-390-A-007-005
Revision Level:	5
Drafted By:	L.McSwiney
Ops Manager	Charlie Roberts
Effective Date:	3/23/2020

OPERATION:	Normal process/equipment start up	STEP NUMBER:	1
------------	-----------------------------------	--------------	---

f. In the truck offload area, connect the grounds together until the light on the box is green.



Take key from locker at truck depot to unlock valves.

g. Open designated valves at the pentane bulk tank, then the steel box, then the railcar.

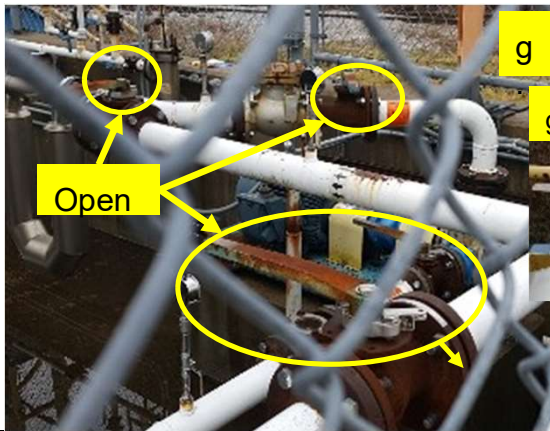

Valves at pentane tank

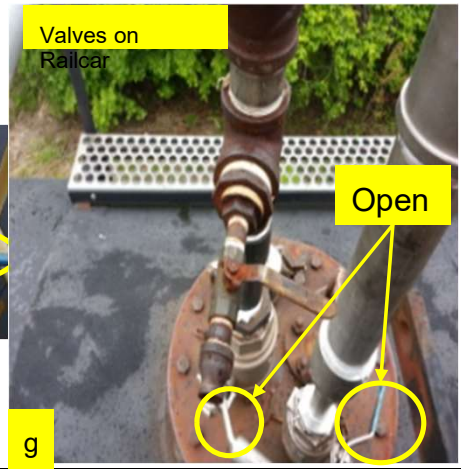
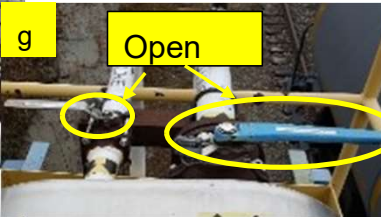



EXCEL WORKING STANDARD

Document No.:	FWS-390-A-007-005
Revision Level:	5
Drafted By:	L.McSwiney
Ops Manager	Charlie Roberts
Effective Date:	3/23/2020

OPERATION: Consequences of deviating from normal operating limits

Safety

DEVIATING FROM NORMAL OPERATION STANDARD CAN CAUSE BODILY INJURY OR DEATH

a. In case of equipment malfunction:

If safe operating limits are exceeded during the normal offloading procedure a supervisor must be notified to reset the system for operation.

b. Resetting system:

System cannot be reset by offloading personnel. Supervisor will determine when/if system is to be reset.



EXCEL WORKING STANDARD

Document No.:	FWS-390-A-007-005
Revision Level:	5
Drafted By:	L.McSwiney
Ops Manager	Charlie Roberts
Effective Date:	3/23/2020

OPERATION:	Safety
<p>Notify supervisor in the event of any deviation from normal procedures or if a standard can be improved.</p> <p>a. The conditions that caused the deviation must be corrected and repaired by maintenance and verified before resuming unload.</p> <p>b. These conditions could include: trailers with side unload, leaking hoses, and vent line problems.</p> <ol style="list-style-type: none">Trailers with side unloads will be unloaded with the same process as: (see Summary Operations)Leaking hoses must not be used and unload stopped immediately. Unload will not restart until a suitable hose has been connected.The vent line must have return pressure from Pentane tanks to the trailer. If there is not any pressure from tanks, contact maintenance immediately.If a spill occurs, unload must be stopped immediately by releasing the dead man switch and pushing E-stop. Truck driver must close all valves on truck and the valves on pipes. The spill must be contained and contact a supervisor immediately. Unload will not resume until the cause of the spill is determine and fixed.	



EXCEL WORKING STANDARD

Document No.:	FWS-390-A-007-005
Revision Level:	5
Drafted By:	L. McSwiney
Ops Manager	Charlie Roberts
Effective Date:	3/23/2020

OPERATION: Certificate of Analysis and Bill of Lading Paperwork 1

- a. Railcar paperwork is faxed or emailed, and posted on the rail board.
 - b. The railcar number and seal tag on the C of A, BOL, and railcar must match before proceeding. Have Quality Control check and sign off on the C of A to ensure the chemical complies with approved Firestone specs.
 - c. Railcar number is located on the rear, top, and side of the railcar.
1. Certificate of Analysis (C of A)
 2. Bill of Lading (BOL)



Rear of Railcar



Top of Railcar

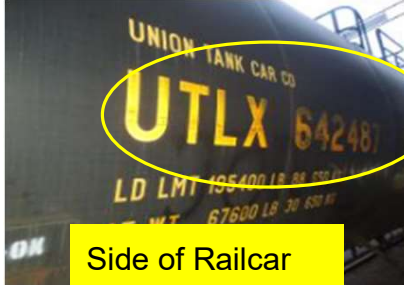

Side of Railcar

HUNTSMAN
Enriching lives through innovation

Certificate of Analysis

Customer: FIRESTONE BUILDING PRODUCTS CO
REV OF HUNTSMAN FIRESTONE INC
1175 HOLETON SQ
FLORISSA KY 41042-1010

Huntsman Order Number: 22567806710
Huntsman Delivery Number: 744925497000001
Customer Order Number: 649171 REL 83 400
Delivery Date: 12/28/2012
Track/Trailer: 07L0642487

Product Name: RUBBERITE 3450 202540
Customer Product No:
For Attention Of:

Parameter Unit Results Sales Specification

Batch 0E051640
Production 12/17/2012
Quantity 0.000

NCI value % 30.5 30.0-31.1
Viscosity @ 25°C cps 637 625-771
Total Acidity as HCL ppm 26 100 MAX
Iron content ppm 2 10 MAX

Notes:
FAX COA TO NASH: MURKETT.NEB @ 415-291-1240
EMAIL COA/S TO: herrett-hubmeyer@firestonebp.com and
@kandeb@firestoneexp.com
SPECIFIC GRAVITY: 1.2499

The material(s) detailed above conform to Huntsman specification

Date of Issue: 12/17/2012

Signature: John E. Prickett
John E. Prickett
Product Development Manager

Document No. 000000402249915

HUNTSMAN
Enriching lives through innovation

Bill of Lading

Customer No. 71442549
Ship Date: 12/17/2012

Product Information: RUBBERITE 3450
Net Weight: 189576 LB

EMERGENCY CONTACT:
For ALL issues with a Huntsman chemical involving a spill, leak, fire, exposure or any emergency please report to CHEMTREC. Call toll free 24 hours a day: 1-800-424-9100 or 1-783-523-2487. Reg. CCN 34896.

Signature of Accounting Agent: [Signature]

Document No.:	FWS-390-A-007-005
Revision Level:	5
Drafted By:	L. McSwiney
Ops Manager	Charlie Roberts
Effective Date:	3/23/2020

OPERATION: Normal process/equipment start up **STEP NUMBER:** 1

a. Set the railcar brake (brake should be set by rail company employee), chock the railcar and attach both ground cables to handrail on railcar.



b. Place "Derail" and "Stop - Men at Work" signs on tracks, and "Stop - Men at Work" sign on back of railcar.

Stop -Men at Work

b



c. Check the security seals on the dome on top of the railcar to make sure they're intact. If they are not intact, contact supervisor.

If intact, cut with wirecutters, put in dome.

Tag goes back to co. with railcar.

d



b

d. Only non-sparking tools are to be used to connect fittings to 3-inch offload and 2-inch return hose. Tighten connectors on plant side first, then to rail car.

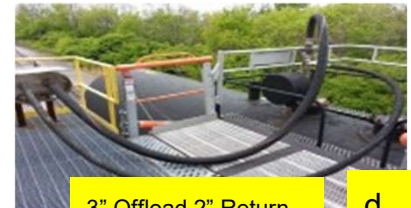

Toolbox for non-sparking tools
PVC storage for hoses & fittings

e. Tools are found in the plastic storage box at top of stairs. Hoses, with fittings attached, are stored in the PVC piping next to the plastic tool storage box.

Document No.:	FWS-390-A-007-005
Revision Level:	5
Drafted By:	L.McSwiney
Ops Manager	Charlie Roberts
Effective Date:	3/23/2020

OPERATION:	Normal process/equipment start up	STEP NUMBER:	1
------------	-----------------------------------	--------------	---

h. Write the number of lbs from the Bulk Pentane Tank onto the C of A sheet.

i. Press the start button, found in the batcher shack.

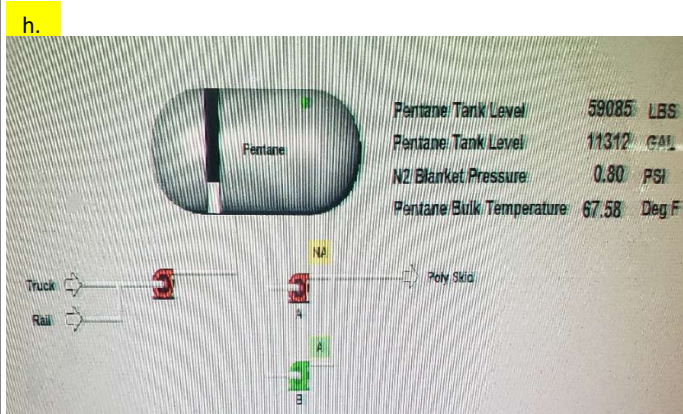

Bulk Pentane Tank

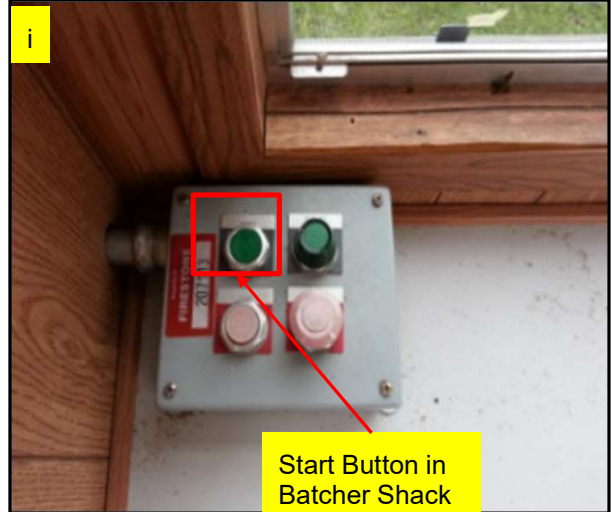

Start Button in Batcher Shack

Document No.:	FWS-390-A-007-005
Revision Level:	5
Drafted By:	L.McSwiney
Ops Manager	Charlie Roberts
Effective Date:	3/23/2020

OPERATION: Normal process/equipment operations

STEP NUMBER: 2



a. Return keys to lockbox by rail offload area.

Rotameter (intake paddle) located inside pentane storage tank containment area

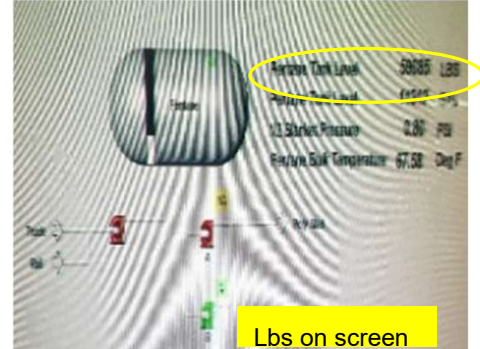

- b. Ensure rotameter is spinning clockwise for proper flow.
- c. Every 15 minutes check lbs on the Bulk Pentane Tank for progress.

Document No.:	FWS-390-A-007-005
Revision Level:	5
Drafted By:	L.McSwiney
Ops Manager	Charlie Roberts
Effective Date:	3/23/2020

OPERATION:	Normal process/equipment shut down	STEP NUMBER:	3
-------------------	---	---------------------	----------

a. Close the valves on the railcar, in the steel box and at the tank.

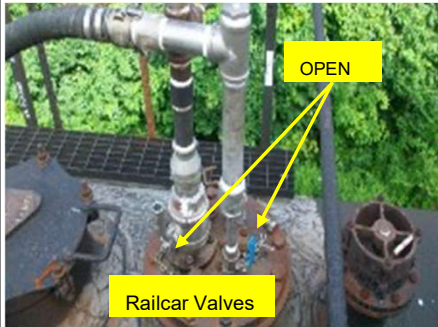

Unhook the 3-inch offload hose and the 2-inch return hose from the railcar. Hold each end of hose up to drain. Once hoses are drained, unhook from steel box. Go to batcher shack, turn pump off.

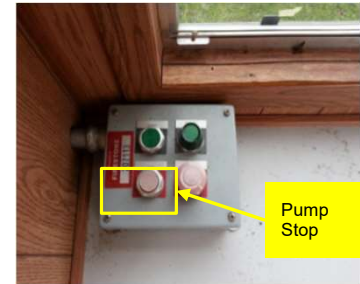
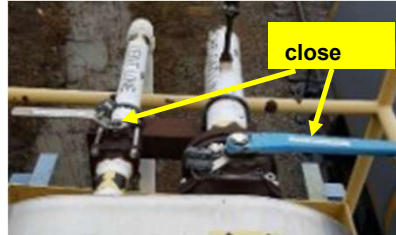

c. Remove the fittings from the railcar using only non-sparking tools.



d. Unhook the ground cables from the railcar as well as the truck area and replace on post.

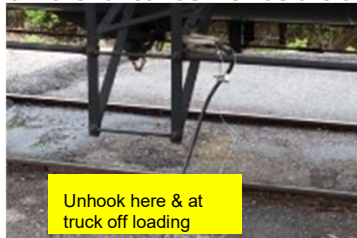

e. Replace hoses, tools, and fittings to proper storage area.



Non-sparking brass wrench storage



EXCEL WORKING STANDARD

Document No.:	FWS-390-A-007-005
Revision Level:	5
Drafted By:	L.McSwiney
Ops Manager	Charlie Roberts
Effective Date:	3/23/2020

OPERATION: Temporary process/equipment operations	STEP NUMBER: 4
--	-----------------------

There are no temporary process or equipment operations for pentane railcar offload.

Document No.:	FWS-390-A-007-005
Revision Level:	5
Drafted By:	L.McSwiney
Ops Manager	Charlie Roberts
Effective Date:	3/23/2020

OPERATION: Emergency shutdown of process/equipment	STEP NUMBER: 5
---	-----------------------

In case of spill or other accident, shut down process immediately.

1. Emergency shutdown:

a. Push nearest Emergency Stop (located in batcher shack, on posts with grounding wires, on fence surrounding pentane tank, on inside dike facing tank, and on outside of building near doorway).

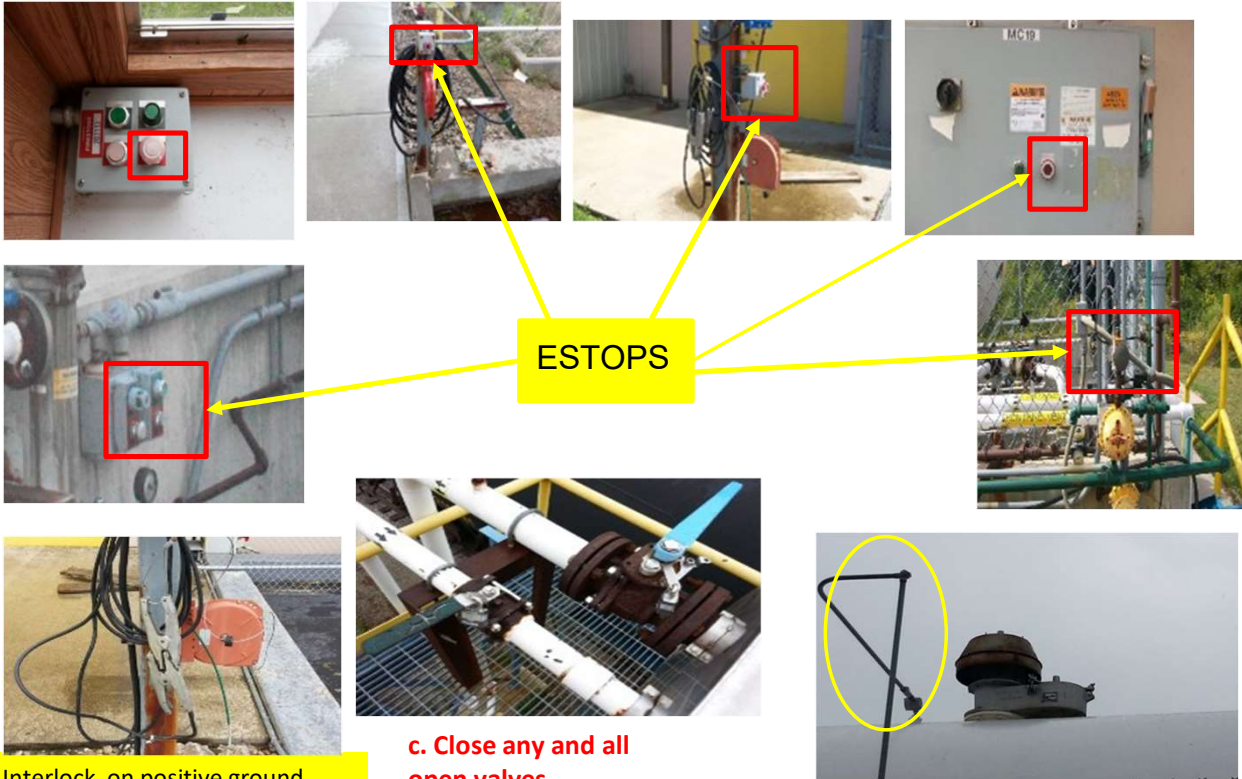

Interlock on positive ground cables at truck offload area

b. Disconnect the ground cables in the truck offload area.

c. Close any and all open valves

2 The tank is equipped with a level sensor which will shut off flow to prevent overflow.

**3. Conditions requiring an emergency stop:
Leak or spill**

Document No.:	FWS-390-A-007-005
Revision Level:	5
Drafted By:	L.McSwiney
Ops Manager	Charlie Roberts
Effective Date:	3/23/2020

OPERATION: 0

STEP NUMBER:

6

a. Once a supervisor has given the go-ahead, reattach both ground cables to the railcar. Reattach ground cables in truck offload area.

a.



Ground

b. Reconnect hoses and fittings if necessary using only non-sparking tools.

b.

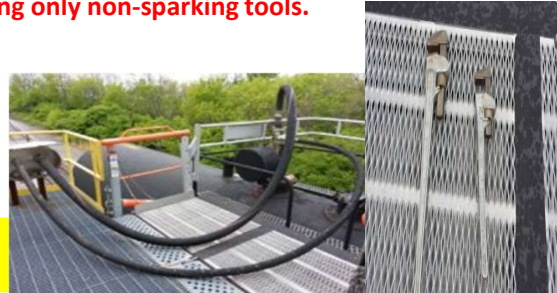

c. Open valves by the tank, then the steel box, and then the railcar.

c.



Valves

d.

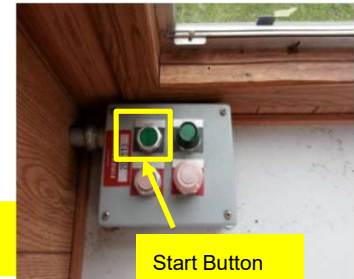

Start Button

d. When all connections have been made and are tight, press start button.



EXCEL WORKING STANDARD

Document No.:	FWS-390-A-007-005
Revision Level:	5
Drafted By:	L.McSwiney
Ops Manager	Charlie Roberts
Effective Date:	3/23/2020

OPERATION:	Railcar Heating	STEP NUMBER:	7
-------------------	------------------------	---------------------	----------

Pentane is not heated prior to unloading.



Re: Notice of Deficiency for AI 71732

From Burton JOYNER <burton.joyner@amrize.com>

Date Tue 3/3/2026 10:48 AM

To Freeman, Colby (EEC) <colby.freeman@ky.gov>

Cc Jesse MEGENHARDT <jesse.megenhardt@amrize.com>; Ross, Dakota D (EEC) <dakota.ross@ky.gov>; jeuler@decaenvironmental.com <jeuler@decaenvironmental.com>; Justin SMITH <justin.smith2@amrize.com>; Harley, Brian (EEC) <Brian.Harley@ky.gov>

1 attachment (427 KB)

Isopentane Acetone Blend.pdf;

****CAUTION** PDF attachments may contain links to malicious sites. Please contact the COT Service Desk ServiceCorrespondence@ky.gov for any assistance.**

This Message Originated from Outside the Organization

This Message Is From an External Sender.

Report Suspicious

Hi Colby,

Thanks for your reply. Real quick, here is an SDS from an alternate supplier. I am working with Trecora to get an accurate SDS and/or Certificate of Analysis for the actual product delivered. We do use the 80/20 blend specifically.

We will address your further comments as soon as possible. Thanks again for your collaboration.

Burton

On Tue, Mar 3, 2026 at 9:27 AM Freeman, Colby (EEC) <colby.freeman@ky.gov> wrote:

Good morning Burton,

Thank you for providing the requested documents. I have a couple clarifying question regarding the liquid stored. Can you confirm that it is an isopentane and acetone mixture? If so, are you aware of when the switch was made to isopentane instead of n-pentane? Pursuant to [40 CFR 60.110c\(e\)](#), the vessel has undergone a "modification" if it is used to store a volatile organic liquid (VOL) that has a greater maximum true vapor pressure (mtvp) than all VOL historically stored or permitted. Isopentane has a higher mtvp than n-pentane. We need documentation showing that isopentane was stored in the vessel on or before October 4, 2023. Otherwise, the tank will be subject to 40 CFR 60, Subpart Kc.

I noticed that you used an 80/20 isopentane/acetone mixture for emission calculations, although the SDS provided indicated up to 99% isopentane may be present. Unless you can provide further justification for use of 80/20 (i.e. order specifications, periodic testing of the liquid in the tank), we

may need to recheck calculations with 99% isopentane assumed to be conservative for emission estimates. *Please provide the information requested above as soon as possible, but no later than March 10, 2026.*

In regard to the alternative means of emission limitation (AMEL), I want to clarify that this is a compliance option under 40 CFR 60.112b(a)(4). The vapor balancing system does not meet the requirements associated with a closed vent system and control device under 40 CFR 60.112b(a)(3). The EPA has approved a similar vapor balancing system as an AMEL for Subpart Kb under [Docket ID EPA-HQ-OAR-2020-0599](#). This approval is specific to the facility which made the request. The Division does not have the authority to deem Amrize in compliance with Subpart Kb based on similar operating practices. Amrize will need to follow the process laid out in [40 CFR 60.114b\(c\)](#) to seek an AMEL. I must emphasize that the approval of any requested AMEL under Subpart Kb lies solely within the discretion of the EPA. In this case, "the Administrator" is the EPA. 40 CFR 60.117b(b) states that the authority of 40 CFR 60.114b is not delated to the States (KY DAQ). If the vessel is subject to Subpart Kc, there is a similar process for obtaining an AMEL, although control equivalent to a 98 percent emission reduction would need to be demonstrated.

Prior to approval of an AMEL, PRB does not believe Amrize will be in compliance with Subpart Kb. We can write the permit in such a way that upon approval, Amrize must follow the conditions set forth in the EPA's approval notice published in the Federal Register to demonstrate compliance with 40 CFR 60.112b(a)(4). Amrize would need to notify the Division of the approval, at which point we would determine whether any changes need to be incorporated into the permit. The Division cannot accept a 95% control efficiency for the vapor balancing system prior to approval of an AMEL. We will include a 90% control efficiency as a conservative estimate in line with [AP-42 Chapter 7.1](#) (see page 7.1-9) for the purposes of compliance with the sitewide emission limitation on VOC. The permit will contain operational and recordkeeping requirements relating to the vapor balancing system to demonstrate compliance with a 90% control efficiency on working losses. You will have the opportunity to review these requirements in a courtesy copy and during the public comment period. Please let me know if you have any questions.

Thanks,

Colby Freeman

Environmental Engineer Technologist I
Chemical Section
Division for Air Quality
300 Sower Blvd
Frankfort, KY 40601
(502) 782 - 1467

From: Burton JOYNER <burton.joyner@amrize.com>
Sent: Monday, March 2, 2026 2:46 PM
To: Freeman, Colby (EEC) <colby.freeman@ky.gov>
Cc: Jesse MEGENHARDT <jesse.megenhardt@amrize.com>; Ross, Dakota D (EEC) <dakota.ross@ky.gov>; jeuler@decaenvironmental.com <jeuler@decaenvironmental.com>; Justin SMITH <justin.smith2@amrize.com>; Harley, Brian (EEC) <Brian.Harley@ky.gov>
Subject: Re: Notice of Deficiency for AI 71732

****CAUTION** PDF attachments may contain links to malicious sites. Please contact the COT Service Desk ServiceCorrespondence@ky.gov for any assistance.**

Hi Colby,

I have attached the 7007J form(s) and the isopentane/acetone blend SDS as requested. After our discussion Thursday, we still concede the tank is subject to Subpart Kb, but it appears we may already be in full compliance with the rule's control requirements through vapor balancing. In light of this I have included two Routine Annual Emission reports: one that includes the use of the vapor balancing control, and one that does not account for that system. I have also included the output from both scenarios in the 7007J form. To summarize, with the vapor balance control in place, we have the PTE of 0.033% of the total pentane blend used annually compared to a PTE of 0.68% when the control is not accounted for.

Our Florence facility would like to claim and file for the AMEL exception to 40 CFR 60, Subpart Kb, specifically under 40 CFR 60.112b(a)(3) regarding the "use of a closed vent system and control device." As requested, I have included our current SOP for operator offload instructions.

Please let us know the next steps you would like us to take. We appreciate your willingness to help us understand and ensure complete compliance with all regulations.

Burton

On Thu, Feb 26, 2026 at 1:11 PM Freeman, Colby (EEC) <colby.freeman@ky.gov> wrote:

Burton,

Once you have determined the maximum throughput for the tank, please calculate potential emissions using EPA's [TANKS Emissions Estimation Software](#). I have linked you to the homepage for AP-42 Chapter 7 with the TANKS software highlighted. You can look into the other links if you have questions about any of the inputs. Specifically, we are looking for routine losses. TANKS can generate a PDF report which will provide all of the information we need for emissions.

We noticed the 7007J form listed a pentane/acetone mixture. This may require adding a custom organic liquid in TANKS to account for the mixture's vapor pressure. Please provide a material safety data sheet along with the 7007J form and emission calculations.

Here is the link to the docket for the alternative means of emission limitation we discussed today. You can find the facility's application and the EPA's approval conditions in the docket documents: [AMEL](#)

Let me know if you have any questions. Thanks,

Colby Freeman

Environmental Engineer Technologist I
Chemical Section
Division for Air Quality
300 Sower Blvd

Frankfort, KY 40601
(502) 782 - 1467

From: Burton JOYNER <burton.joyner@amrize.com>
Sent: Wednesday, February 25, 2026 1:13 PM
To: Freeman, Colby (EEC) <colby.freeman@ky.gov>
Cc: Jesse MEGENHARDT <jesse.megenhardt@amrize.com>; Ross, Dakota D (EEC) <dakota.ross@ky.gov>;
jeuler@decaenvironmental.com <jeuler@decaenvironmental.com>; Justin SMITH
<justin.smith2@amrize.com>; Harley, Brian (EEC) <Brian.Harley@ky.gov>
Subject: Re: Notice of Deficiency for AI 71732

Thanks. I sent an invitation for tomorrow at 11AM eastern time.

On Wed, Feb 25, 2026 at 1:04 PM Freeman, Colby (EEC) <colby.freeman@ky.gov> wrote:
Burton,

We will be available from 10-12 tomorrow.

Thanks,

Colby Freeman

Environmental Engineer Technologist I
Chemical Section
Division for Air Quality
300 Sower Blvd
Frankfort, KY 40601
(502) 782 - 1467

From: Burton JOYNER <burton.joyner@amrize.com>
Sent: Wednesday, February 25, 2026 12:48 PM
To: Freeman, Colby (EEC) <colby.freeman@ky.gov>
Cc: Jesse MEGENHARDT <jesse.megenhardt@amrize.com>; Ross, Dakota D (EEC) <dakota.ross@ky.gov>;
jeuler@decaenvironmental.com <jeuler@decaenvironmental.com>; Justin SMITH
<justin.smith2@amrize.com>; Harley, Brian (EEC) <Brian.Harley@ky.gov>
Subject: Re: Notice of Deficiency for AI 71732

Hi Colby,

Would the DAQ PRB be agreeable to a call to review the DEP7007J form with Amrize's team? We have some questions and feel it would benefit us to talk it through to make sure we get you the information you need to issue the conditional permit. If so, I can set something up for tomorrow or Friday.

Thanks,

Burton

On Mon, Feb 23, 2026 at 2:41 PM Burton JOYNER <burton.joyner@amrize.com> wrote:
Hi Colby,

Please forgive my delay in reply. I have been consumed with environmental reporting for all of my locations. I do intend to fill out the requested form this week which should provide you with all the information you need. I will get it to you as soon as I can.

Thanks for your patience.

Burton

On Mon, Feb 23, 2026 at 2:04 PM Freeman, Colby (EEC) <colby.freeman@ky.gov> wrote:

Jesse,

I am following up on the tank emission estimate request below. The Division has determined the pentane storage vessel, as it currently stands and is operated by Amrize, is subject to 40 CFR 60, Subpart Kb. We plan to issue the draft renewal permit with the vessel listed in Section B of the permit along with all of the compliance options and applicable requirements of Subpart Kb. Tank information and emission estimates are necessary to declare the application complete and proceed with issuance of the permit. *Please provide this information as soon as possible, but no later than March 2, 2026.*

If Amrize believes the proposed method of compliance will exempt the tank from the requirements of Subpart Kb pursuant to the pressure vessel exemption at 40 CFR 60.110b(d) (2), this would need to be incorporated into the permit as a preclusion of Subpart Kb. After implementing the change, Amrize would need to submit a significant revision application. The Division would likely include monitoring and recordkeeping requirements to demonstrate the vessel is designed to operate in excess of 204.9 kPa and without emissions to the atmosphere, including during tank filling operations.

Thanks,

Colby Freeman

Environmental Engineer Technologist I

Chemical Section

Division for Air Quality

[300 Sower Blvd](#)

[Frankfort, KY 40601](#)

(502) 782 - 1467

From: Ross, Dakota D (EEC) <dakota.ross@ky.gov>

Sent: Monday, February 16, 2026 10:14 AM

To: Jesse MEGENHARDT <jesse.megenhardt@amrize.com>; Freeman, Colby (EEC) <colby.freeman@ky.gov>

Cc: jeuler@decaenvironmental.com <jeuler@decaenvironmental.com>; Justin SMITH <justin.smith2@amrize.com>; Burton JOYNER <burton.joyner@amrize.com>; Harley, Brian (EEC) <Brian.Harley@ky.gov>

Subject: RE: Notice of Deficiency for AI 71732

Thank you Jesse,

The Division will review and follow up if we have any questions.

In the meantime could you please provide a DEP 7007J form (<https://eec.ky.gov/Environmental-Protection/Air/Pages/Air-Permitting-Forms-and-Information.aspx>) for the tank and potential emission estimates for both how the tank is currently operating and how the tank will operate after the change using AP-42 Chapter 7.1 methodology/ EPAs Tanks 5.1 software.

Thanks,

Dakota Ross, P.E.

Environmental Engineer

Permit Review Branch

Division for Air Quality

[300 Sower Blvd](#)

[Frankfort, KY 40601](#)

(502) 782 - 6479

From: Jesse MEGENHARDT <jesse.megenhardt@amrize.com>

Sent: Friday, February 13, 2026 10:09 AM

To: Freeman, Colby (EEC) <colby.freeman@ky.gov>

Cc: jeuler@decaenvironmental.com; Justin SMITH <justin.smith2@amrize.com>; Burton JOYNER <burton.joyner@amrize.com>; Ross, Dakota D (EEC) <dakota.ross@ky.gov>; Harley, Brian (EEC) <Brian.Harley@ky.gov>

Subject: Re: Notice of Deficiency for AI 71732

****CAUTION** PDF attachments may contain links to malicious sites. Please contact the COT Service Desk ServiceCorrespondence@ky.gov for any assistance.**

Dear Colby,

Please find attached our proposed solution and implementation plan to address the applicability of 40 CFR, Subpart Kb and the Notice of Deficiency of AL 71732.

Kindly acknowledge the receipt of this email. If you have any questions or concerns please do not hesitate to contact me.

Best Regards,

Jesse Megenhardt

Sr. Plant Manager

jesse.megenhardt@amrize.com

Amrize

[8170 Holton Drive, Florence, KY, USA, Florence, United States, 41042](#)

T: 41042, M: 5025250774

[Amrize](#) | [LinkedIn](#) | [Facebook](#)

This email is confidential and intended only for the use of the above named addressee. If you have received this email in error, please delete it immediately and notify us by email or telephone.

On Fri, Jan 9, 2026 at 10:29 AM Freeman, Colby (EEC) <colby.freeman@ky.gov> wrote:

Jesse,

The Division has received your response.

Thanks,

Colby Freeman

Environmental Engineer Technologist I

Chemical Section

Division for Air Quality

[300 Sower Blvd](#)

[Frankfort, KY 40601](#)

(502) 782 - 1467

From: Jesse MEGENHARDT <jesse.megenhardt@amrize.com>

Sent: Friday, January 9, 2026 10:13 AM

To: Freeman, Colby (EEC) <colby.freeman@ky.gov>

Cc: jeuler@decaenvironmental.com <jeuler@decaenvironmental.com>; Justin SMITH <justin.smith2@amrize.com>; Burton JOYNER <burton.joyner@amrize.com>; Ross, Dakota D (EEC) <dakota.ross@ky.gov>; Harley, Brian (EEC) <Brian.Harley@ky.gov>

Subject: Re: Notice of Deficiency for AI 71732

****CAUTION** PDF attachments may contain links to malicious sites. Please contact the COT Service Desk ServiceCorrespondence@ky.gov for any assistance.**

Dear Colby,

Please find the attached response regarding the potential applicability of 40 CFR 60, Subpart Kb and the Notice of Deficiency for AI 71732.

Kindly acknowledge receipt of this email.

Best Regards,

Jesse Megenhardt

Sr. Plant Manager

jesse.megenhardt@amrize.com

Amrize

[8170 Holton Drive, Florence, KY, USA, Florence, United States, 41042](#)

T: 41042, M: 5025250774

[Amrize](#) | [LinkedIn](#) | [Facebook](#)

This email is confidential and intended only for the use of the above named addressee. If you have received this email in error, please delete it immediately and notify us by email or telephone.

On Wed, Dec 10, 2025 at 7:55 AM Freeman, Colby (EEC) <colby.freeman@ky.gov> wrote:

Good morning,

Attached is the first Notice of Deficiency for the Conditional Major renewal application for Amrize Building Envelope LLC. This serves as your official copy and a paper copy will not be sent. We request that you submit the information as soon as possible, but in no case later than January 9, 2026.

Please feel free to contact me if you have any questions or need additional clarification.

Thanks,

Colby Freeman

Environmental Engineer Technologist I

Chemical Section

Division for Air Quality

[300 Sower Blvd](#)

[Frankfort, KY 40601](#)

(502) 782 - 1467

SECTION 1: IDENTIFICATION

1.1. Product Identifier

Product Form: Mixture

Product Name: Isopentane/Acetone Blend (80/20)

1.2. Intended Use of the Product

Use of the Substance/Mixture: No use is specified.

1.3. Name, Address, and Telephone of the Responsible Party

Company

Aeropres Corporation
1324 N. Hearne Avenue
Suite 200
Shreveport, LA 71107
Phone: 318-221-6282
Website: www.aeropres.com

1.4. Emergency Telephone Number

Emergency Number : 800-424-9300 (CHEMTREC); (International) +01 703-527-3887

SECTION 2: HAZARDS IDENTIFICATION

2.1. Classification of the Substance or Mixture

GHS-US Classification

Flam. Liq. 1	H224
Eye Irrit. 2	H319
STOT SE 3	H336
Asp. Tox. 1	H304
Aquatic Acute 2	H401
Aquatic Chronic 2	H411

Full text of hazard classes and H-statements : see Section 16.

2.2. Label Elements

GHS-US Labeling

Hazard Pictograms (GHS-US)



Signal Word (GHS-US)

: Danger

Hazard Statements (GHS-US)

: H224 - Extremely flammable liquid and vapor.
H304 - May be fatal if swallowed and enters airways.
H319 - Causes serious eye irritation.
H336 - May cause drowsiness or dizziness.
H401 - Toxic to aquatic life.
H411 - Toxic to aquatic life with long lasting effects.

Precautionary Statements (GHS-US)

: P210 - Keep away from extremely high or low temperatures, ignition sources, and incompatible materials. - No smoking.
P240 - Ground/Bond container and receiving equipment.
P241 - Use explosion-proof electrical, ventilating, and lighting equipment.
P242 - Use only non-sparking tools.
P243 - Take precautionary measures against static discharge.
P261 - Avoid breathing vapors, mist, or spray.
P264 - Wash hands, forearms, and other exposed areas thoroughly after handling.
P271 - Use only outdoors or in a well-ventilated area.
P273 - Avoid release to the environment.
P280 - Wear protective gloves, protective clothing, and eye protection.
P301+P310 - If swallowed: Immediately call a poison center or doctor.
P303+P361+P353 - If on skin (or hair): Take off immediately all contaminated clothing. Rinse skin with water/shower.
P304+P340 - If inhaled: Remove person to fresh air and keep at rest in a position

Isopentane/Acetone Blend (80/20)

Safety Data Sheet

According to Federal Register / Vol. 77, No. 58 / Monday, March 26, 2012 / Rules and Regulations

comfortable for breathing.

P305+P351+P338 - If in eyes: Rinse cautiously with water for several minutes.

Remove contact lenses, if present and easy to do. Continue rinsing.

P312 - Call a poison center or doctor if you feel unwell.

P331 - Do NOT induce vomiting.

P337+P313 - If eye irritation persists: Get medical advice/attention.

P370+P378 - In case of fire: Use appropriate media (see Section 5) to extinguish.

P391 - Collect spillage.

P405 - Store locked up.

P501 - Dispose of contents/container in accordance with local, regional, national, and international regulations.

P403+P233+P235 - Store in a well-ventilated place. Keep container tightly closed. Keep cool.

2.3. Other Hazards

Exposure may aggravate pre-existing eye, skin, or respiratory conditions.

2.4. Unknown Acute Toxicity (GHS-US)

No data available

SECTION 3: COMPOSITION/INFORMATION ON INGREDIENTS

3.2. Mixture

Name	Product Identifier	%	GHS-US classification
Isopentane	(CAS-No.) 78-78-4	78 - 84	Flam. Liq. 1, H224 STOT SE 3, H336 Asp. Tox. 1, H304 Aquatic Acute 2, H401 Aquatic Chronic 2, H411
Acetone	(CAS-No.) 67-64-1	16 - 22	Flam. Liq. 2, H225 Eye Irrit. 2A, H319 STOT SE 3, H336

Full text of H-phrases: see Section 16.

SECTION 4: FIRST AID MEASURES

4.1. Description of First-aid Measures

First-aid Measures General: Never give anything by mouth to an unconscious person. If you feel unwell, seek medical advice (show the label where possible).

First-aid Measures After Inhalation: When symptoms occur: go into open air and ventilate suspected area. Obtain medical attention if breathing difficulty persists.

First-aid Measures After Skin Contact: Remove contaminated clothing. Drench affected area with water for at least 15 minutes. Obtain medical attention if irritation develops or persists.

First-aid Measures After Eye Contact: Rinse cautiously with water for at least 15 minutes. Remove contact lenses, if present and easy to do. Continue rinsing. Obtain medical attention.

First-aid Measures After Ingestion: Do NOT induce vomiting. Rinse mouth. Immediately call a POISON CENTER or doctor/physician.

4.2. Most Important Symptoms and Effects Both Acute and Delayed

Symptoms/Injuries: Causes serious eye irritation. May cause drowsiness and dizziness. May be fatal if swallowed and enters airways.

Symptoms/Injuries After Inhalation: High concentrations may cause central nervous system depression such as dizziness, vomiting, numbness, drowsiness, headache, and similar narcotic symptoms.

Symptoms/Injuries After Skin Contact: Prolonged exposure may cause skin irritation.

Symptoms/Injuries After Eye Contact: Contact causes severe irritation with redness and swelling of the conjunctiva.

Symptoms/Injuries After Ingestion: The major health threat of ingestion occurs from the danger of aspiration (breathing) of liquid drops into the lungs, particularly from vomiting. Aspiration may result in chemical pneumonia (fluid in the lungs), severe lung damage, respiratory failure and even death.

Chronic Symptoms: None expected under normal conditions of use.

4.3. Indication of Any Immediate Medical Attention and Special Treatment Needed

If exposed or concerned, get medical advice and attention. If medical advice is needed, have product container or label at hand.

Isopentane/Acetone Blend (80/20)

Safety Data Sheet

According to Federal Register / Vol. 77, No. 58 / Monday, March 26, 2012 / Rules and Regulations

SECTION 5: FIRE-FIGHTING MEASURES

5.1. Extinguishing Media

Suitable Extinguishing Media: Dry chemical powder, alcohol-resistant foam, carbon dioxide (CO₂). Water may be ineffective but water should be used to keep fire-exposed container cool.

Unsuitable Extinguishing Media: Do not use a heavy water stream. A heavy water stream may spread burning liquid.

5.2. Special Hazards Arising From the Substance or Mixture

Fire Hazard: Extremely flammable liquid and vapor.

Explosion Hazard: May form flammable or explosive vapor-air mixture.

Reactivity: Reacts violently with strong oxidizers. Increased risk of fire or explosion.

5.3. Advice for Firefighters

Precautionary Measures Fire: Exercise caution when fighting any chemical fire.

Firefighting Instructions: Use water spray or fog for cooling exposed containers. In case of major fire and large quantities: Evacuate area. Fight fire remotely due to the risk of explosion.

Protection During Firefighting: Do not enter fire area without proper protective equipment, including respiratory protection.

Hazardous Combustion Products: Carbon oxides (CO, CO₂). Nitrogen oxides.

Other Information: Do not allow run-off from fire fighting to enter drains or water courses.

SECTION 6: ACCIDENTAL RELEASE MEASURES

6.1. Personal Precautions, Protective Equipment and Emergency Procedures

General Measures: Avoid breathing (vapor, mist, spray). Do not get in eyes, on skin, or on clothing. Keep away from heat, hot surfaces, sparks, open flames, and other ignition sources. No smoking. Use special care to avoid static electric charges. Avoid all contact with skin, eyes, or clothing.

6.1.1. For Non-Emergency Personnel

Protective Equipment: Use appropriate personal protective equipment (PPE).

Emergency Procedures: Evacuate unnecessary personnel. Stop leak if safe to do so.

6.1.2. For Emergency Personnel

Protective Equipment: Equip cleanup crew with proper protection.

Emergency Procedures: Upon arrival at the scene, a first responder is expected to recognize the presence of dangerous goods, protect oneself and the public, secure the area, and call for the assistance of trained personnel as soon as conditions permit. Ventilate area. Eliminate ignition sources.

6.2. Environmental Precautions

Prevent entry to sewers and public waters. Avoid release to the environment. Collect spillage.

6.3. Methods and Materials for Containment and Cleaning Up

For Containment: Contain any spills with dikes or absorbents to prevent migration and entry into sewers or streams. As an immediate precautionary measure, isolate spill or leak area in all directions.

Methods for Cleaning Up: Clean up spills immediately and dispose of waste safely. Transfer spilled material to a suitable container for disposal. Contact competent authorities after a spill. Absorb and/or contain spill with inert material. Do not take up in combustible material such as: saw dust or cellulosic material. Use only non-sparking tools.

6.4. Reference to Other Sections

See Section 8 for exposure controls and personal protection and Section 13 for disposal considerations.

SECTION 7: HANDLING AND STORAGE

7.1. Precautions for Safe Handling

Additional Hazards When Processed: Handle empty containers with care because residual vapors are flammable. Any proposed use of this product in elevated-temperature processes should be thoroughly evaluated to assure that safe operating conditions are established and maintained.

Precautions for Safe Handling: Wash hands and other exposed areas with mild soap and water before eating, drinking or smoking and when leaving work. Avoid breathing vapors, mist, spray. Take precautionary measures against static discharge. Use only non-sparking tools.

Hygiene Measures: Handle in accordance with good industrial hygiene and safety procedures.

7.2. Conditions for Safe Storage, Including Any Incompatibilities

Technical Measures: Comply with applicable regulations. Take action to prevent static discharges. Ground and bond container and receiving equipment. Use explosion-proof electrical, ventilating, and lighting equipment.

Storage Conditions: Store in a dry, cool place. Keep/Store away from direct sunlight, extremely high or low temperatures and incompatible materials. Store in a well-ventilated place. Keep container tightly closed. Keep in fireproof place.

Incompatible Materials: Strong acids, strong bases, strong oxidizers, amines, alkalis.

Isopentane/Acetone Blend (80/20)

Safety Data Sheet

According to Federal Register / Vol. 77, No. 58 / Monday, March 26, 2012 / Rules and Regulations

7.3. Specific End Use(s)

No use is specified.

SECTION 8: EXPOSURE CONTROLS/PERSONAL PROTECTION

8.1. Control Parameters

For substances listed in Section 3 that are not listed here, there are no established exposure limits from the manufacturer, supplier, importer, or the appropriate advisory agency including: ACGIH (TLV), AIHA (WEEL), NIOSH (REL), or OSHA (PEL).

Isopentane (78-78-4)		
USA ACGIH	ACGIH TWA (ppm)	1000 ppm
Acetone (67-64-1)		
USA ACGIH	ACGIH TWA (ppm)	250 ppm
USA ACGIH	ACGIH STEL (ppm)	500 ppm
USA ACGIH	ACGIH chemical category	Not Classifiable as a Human Carcinogen
USA ACGIH	Biological Exposure Indices (BEI)	25 mg/l Parameter: Acetone - Medium: urine - Sampling time: end of shift (nonspecific)
USA NIOSH	NIOSH REL (TWA) (mg/m ³)	590 mg/m ³
USA NIOSH	NIOSH REL (TWA) (ppm)	250 ppm
USA IDLH	US IDLH (ppm)	2500 ppm (10% LEL)
USA OSHA	OSHA PEL (TWA) (mg/m ³)	2400 mg/m ³
USA OSHA	OSHA PEL (TWA) (ppm)	1000 ppm

8.2. Exposure Controls

Appropriate Engineering Controls

: Emergency eye wash fountains and safety showers should be available in the immediate vicinity of any potential exposure. Ensure adequate ventilation, especially in confined areas. Ensure all national/local regulations are observed. Gas detectors should be used when flammable gases or vapors may be released. Proper grounding procedures to avoid static electricity should be followed. Use explosion-proof equipment.

Personal Protective Equipment

: Gloves. Protective clothing. Protective goggles. Insufficient ventilation: wear respiratory protection.

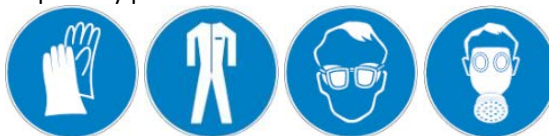

Materials for Protective Clothing

: Chemically resistant materials and fabrics. Wear fire/flamm resistant/retardant clothing.

Hand Protection

: Nitrile gloves.

Eye and Face Protection

: Chemical safety goggles and face shield.

Skin and Body Protection

: Wear suitable protective clothing.

Respiratory Protection

: If exposure limits are exceeded or irritation is experienced, approved respiratory protection should be worn. In case of inadequate ventilation, oxygen deficient atmosphere, or where exposure levels are not known wear approved respiratory protection.

Other Information

: When using, do not eat, drink or smoke.

SECTION 9: PHYSICAL AND CHEMICAL PROPERTIES

9.1. Information on Basic Physical and Chemical Properties

Physical State	: Liquid
Appearance	: Blend
Odor	: Fruity, Mint Like Ethereal, Slight Gasoline
Odor Threshold	: 62 ppm
pH	: No data available
Evaporation Rate	: No data available
Melting Point	: -95.35 - -159 °C (-139.63 - -254.2 °F)
Freezing Point	: No data available
Boiling Point	: 28 - 56.2 °C (82.4 - 133.16 °F)
Flash Point	: -20 - -51 °C (-4 - -59.8 °F)

Isopentane/Acetone Blend (80/20)

Safety Data Sheet

According to Federal Register / Vol. 77, No. 58 / Monday, March 26, 2012 / Rules and Regulations

Critical Temperature	: 235 °C (455 °F)
Auto-ignition Temperature	: 420 - 465 °C (788 - 869 °F)
Decomposition Temperature	: No data available
Flammability (solid, gas)	: Not applicable
Vapor Pressure	: 14 - 20.4 psia @ 20 °C (68 °F)
Relative Vapor Density at 20°C	: No data available
Relative Density	: No data available
Specific Gravity	: 0.6197 - 0.7921
Density	: 2 - 2.6 kg/m ³ (AIR = 1)
Solubility	: Water: Easily Soluble in Water
Partition Coefficient: N-Octanol/Water	: No data available
Viscosity	: No data available
Lower Flammable Limit	: 1.4 - 2.6 %
Upper Flammable Limit	: 7.6 - 12.80 %

9.2. Other Information

No additional information available

SECTION 10: STABILITY AND REACTIVITY

- 10.1. Reactivity:** Reacts violently with strong oxidizers. Increased risk of fire or explosion.
- 10.2. Chemical Stability:** Extremely flammable liquid and vapor. May form flammable or explosive vapor-air mixture.
- 10.3. Possibility of Hazardous Reactions:** Hazardous polymerization will not occur.
- 10.4. Conditions to Avoid:** Direct sunlight, extremely high or low temperatures, heat, hot surfaces, sparks, open flames, incompatible materials, and other ignition sources.
- 10.5. Incompatible Materials:** Strong acids, strong bases, strong oxidizers, amines, alkalis.
- 10.6. Hazardous Decomposition Products:** None expected under normal conditions of use.

SECTION 11: TOXICOLOGICAL INFORMATION

11.1. Information on Toxicological Effects

Acute Toxicity: Not classified

Acetone (67-64-1)	
LD50 Oral Rat	5800 mg/kg
LD50 Dermal Rabbit	15688 mg/kg
LC50 Inhalation Rat	44 g/m ³

Skin Corrosion/Irritation: Not classified

Serious Eye Damage/Irritation: Causes serious eye irritation.

Respiratory or Skin Sensitization: Not classified

Germ Cell Mutagenicity: Not classified

Carcinogenicity: Not classified

Reproductive Toxicity: Not classified

Specific Target Organ Toxicity (Single Exposure): May cause drowsiness or dizziness.

Specific Target Organ Toxicity (Repeated Exposure): Not classified

Aspiration Hazard: May be fatal if swallowed and enters airways.

Symptoms/Injuries After Inhalation: High concentrations may cause central nervous system depression such as dizziness, vomiting, numbness, drowsiness, headache, and similar narcotic symptoms.

Symptoms/Injuries After Skin Contact: Prolonged exposure may cause skin irritation.

Symptoms/Injuries After Eye Contact: Contact causes severe irritation with redness and swelling of the conjunctiva.

Symptoms/Injuries After Ingestion: The major health threat of ingestion occurs from the danger of aspiration (breathing) of liquid drops into the lungs, particularly from vomiting. Aspiration may result in chemical pneumonia (fluid in the lungs), severe lung damage, respiratory failure and even death.

Chronic Symptoms: None expected under normal conditions of use.

SECTION 12: ECOLOGICAL INFORMATION

12.1. Toxicity

Ecology - General : Toxic to aquatic life. Toxic to aquatic life with long lasting effects.

Isopentane (78-78-4)	
EC50 Daphnia 1	2.3 mg/l (Exposure time: 48 h - Species: Daphnia magna)

Isopentane/Acetone Blend (80/20)

Safety Data Sheet

According to Federal Register / Vol. 77, No. 58 / Monday, March 26, 2012 / Rules and Regulations

Acetone (67-64-1)	
LC50 Fish 1	4144.846 mg/l (Exposure time: 96 h - Species: Oncorhynchus mykiss)
EC50 Daphnia 1	1679.66 mg/l (Exposure time: 48 h - Species: Daphnia magna [Static])
LC50 Fish 2	6210 (6210 - 8120) mg/l (Exposure time: 96 h - Species: Pimephales promelas [static])
EC50 Daphnia 2	12600 (12600 - 12700) mg/l (Exposure time: 48 h - Species: Daphnia magna)

12.2. Persistence and Degradability

Isopentane/Acetone Blend (80/20)	
Persistence and Degradability	May cause long-term adverse effects in the environment.

Acetone (67-64-1)	
Persistence and Degradability	Readily biodegradable in water.

12.3. Bioaccumulative Potential

Isopentane/Acetone Blend (80/20)	
Bioaccumulative Potential	Not established.

Isopentane (78-78-4)	
Log Pow	3.2 - 3.3

Acetone (67-64-1)	
BCF Fish 1	0.69
Log Pow	-0.24
Log Kow	-0.24

12.4. Mobility in Soil

No additional information available

12.5. Other Adverse Effects

Other Information : Avoid release to the environment.

SECTION 13: DISPOSAL CONSIDERATIONS

13.1. Waste Treatment Methods

Waste Disposal Recommendations: Dispose of contents/container in accordance with local, regional, national, and international regulations.

Additional Information: Handle empty containers with care because residual vapors are flammable.

Ecology - Waste Materials: Avoid release to the environment. This material is hazardous to the aquatic environment. Keep out of sewers and waterways.

SECTION 14: TRANSPORT INFORMATION

The shipping description(s) stated herein were prepared in accordance with certain assumptions at the time the SDS was authored, and can vary based on a number of variables that may or may not have been known at the time the SDS was issued.

14.1. In Accordance with DOT

Proper Shipping Name : PENTANES SOLUTION
Hazard Class : 3
Identification Number : UN1265
Label Codes : 3
Packing Group : I
Marine Pollutant : Marine pollutant
ERG Number : 128



14.2. In Accordance with IMDG

Proper Shipping Name : PENTANES SOLUTION
Hazard Class : 3
Identification Number : UN1265
Packing Group : I
Label Codes : 3
EmS-No. (Fire) : F-E
EmS-No. (Spillage) : S-D
Marine Pollutant : Marine pollutant



14.3. In Accordance with IATA

Proper Shipping Name : PENTANES SOLUTION

Isopentane/Acetone Blend (80/20)

Safety Data Sheet

According to Federal Register / Vol. 77, No. 58 / Monday, March 26, 2012 / Rules and Regulations

Packing Group : 1
Identification Number : UN1265
Hazard Class : 3
Label Codes : 3
ERG Code (IATA) : 3H



SECTION 15: REGULATORY INFORMATION

15.1. US Federal Regulations

Isopentane/Acetone Blend (80/20)	
SARA Section 311/312 Hazard Classes	Fire hazard Immediate (acute) health hazard
Isopentane (78-78-4)	
Listed on the United States TSCA (Toxic Substances Control Act) inventory	
Acetone (67-64-1)	
Listed on the United States TSCA (Toxic Substances Control Act) inventory	
CERCLA RQ	5000 lb

15.2. US State Regulations

Isopentane (78-78-4)
U.S. - Massachusetts - Right To Know List U.S. - New Jersey - Right to Know Hazardous Substance List U.S. - Pennsylvania - RTK (Right to Know) List
Acetone (67-64-1)
U.S. - Massachusetts - Right To Know List U.S. - New Jersey - Right to Know Hazardous Substance List U.S. - Pennsylvania - RTK (Right to Know) - Environmental Hazard List U.S. - Pennsylvania - RTK (Right to Know) List

SECTION 16: OTHER INFORMATION, INCLUDING DATE OF PREPARATION OR LAST REVISION

Date of Preparation or Latest Revision : 02/02/2018
Other Information : This document has been prepared in accordance with the SDS requirements of the OSHA Hazard Communication Standard 29 CFR 1910.1200

GHS Full Text Phrases:

Aquatic Acute 2	Hazardous to the aquatic environment - Acute Hazard Category 2
Aquatic Chronic 2	Hazardous to the aquatic environment - Chronic Hazard Category 2
Asp. Tox. 1	Aspiration hazard Category 1
Eye Irrit. 2	Serious eye damage/eye irritation Category 2
Eye Irrit. 2A	Serious eye damage/eye irritation Category 2A
Flam. Liq. 1	Flammable liquids Category 1
Flam. Liq. 2	Flammable liquids Category 2
STOT SE 3	Specific target organ toxicity (single exposure) Category 3
H224	Extremely flammable liquid and vapor
H225	Highly flammable liquid and vapor
H304	May be fatal if swallowed and enters airways
H319	Causes serious eye irritation
H336	May cause drowsiness or dizziness
H401	Toxic to aquatic life
H411	Toxic to aquatic life with long lasting effects

NFPA Health Hazard : 3 - Materials that, under emergency conditions, can cause serious or permanent injury.

NFPA Fire Hazard : 4 - Materials that rapidly or completely vaporize at atmospheric pressure and normal ambient temperature or that are readily dispersed in air and burn readily.

Isopentane/Acetone Blend (80/20)

Safety Data Sheet

According to Federal Register / Vol. 77, No. 58 / Monday, March 26, 2012 / Rules and Regulations

NFPA Reactivity Hazard

: 0 - Material that in themselves are normally stable, even under fire conditions.

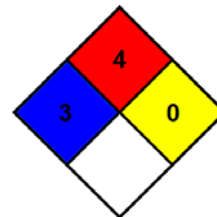

This information relates to this specific material. It may not be valid for this material if used in combination with any other materials or in any process. It is the user's responsibility to satisfy oneself as to the suitability and completeness of this information for one's own particular use.

SDS US (GHS HazCom)



Re: Notice of Deficiency for AI 71732

From Burton JOYNER <burton.joyner@amrize.com>

Date Fri 3/6/2026 4:08 PM

To Freeman, Colby (EEC) <colby.freeman@ky.gov>

Cc Jesse MEGENHARDT <jesse.megenhardt@amrize.com>; Ross, Dakota D (EEC) <dakota.ross@ky.gov>; jeuler@decaenvironmental.com <jeuler@decaenvironmental.com>; Justin SMITH <justin.smith2@amrize.com>; Harley, Brian (EEC) <Brian.Harley@ky.gov>; Jim STODGHILL <jim.stodghill@amrize.com>

3 attachments (546 KB)

Florence Pentane Tank (TK-01) Routine Annual Emissions 90% Control Efficiency.pdf; COATrecor™IPAC100.pdf; 01 - 2022-Pentane 80-20.pdf;

****CAUTION** PDF attachments may contain links to malicious sites. Please contact the COT Service Desk ServiceCorrespondence@ky.gov for any assistance.**

This Message Originated from Outside the Organization

This Message Is From an External Sender.

Report Suspicious

Good afternoon Colby,

Attached are the items that you requested.

- 1) The MOC documentation shows that the conversion from pentane to the isopentane/acetone blend was completed in the fall of 2022.
- 2) The certificate of analysis shows that the product delivered from Trecora is an 80/20 blend of isopentane and acetone.
- 3) The Tanks calculation was redone using a 90% control efficiency as allowed by the PRB.

Please let us know if you have any questions or need any further information.

Also, we are working internally to prepare our application for the AMEL under 40 CFR 60.112b(a) (4) and will follow the process laid out in [40 CFR 60.114b\(c\)](#). We will keep the PRB apprised of when we submit the application and follow up when we hear back from the EPA.

Please let us know the next steps and the monitoring requirements necessary while we wait for the EPA decision.

Thanks again for your patience and collaboration while working through this issue. Have a great weekend.

Burton

On Tue, Mar 3, 2026 at 9:27 AM Freeman, Colby (EEC) <colby.freeman@ky.gov> wrote:

Good morning Burton,

Thank you for providing the requested documents. I have a couple clarifying question regarding the liquid stored. Can you confirm that it is an isopentane and acetone mixture? If so, are you aware of when the switch was made to isopentane instead of n-pentane? Pursuant to [40 CFR 60.110c\(e\)](#), the vessel has undergone a "modification" if it is used to store a volatile organic liquid (VOL) that has a greater maximum true vapor pressure (mtvp) than all VOL historically stored or permitted. Isopentane has a higher mtvp than n-pentane. We need documentation showing that isopentane was stored in the vessel on or before October 4, 2023. Otherwise, the tank will be subject to 40 CFR 60, Subpart Kc.

I noticed that you used an 80/20 isopentane/acetone mixture for emission calculations, although the SDS provided indicated up to 99% isopentane may be present. Unless you can provide further justification for use of 80/20 (i.e. order specifications, periodic testing of the liquid in the tank), we may need to recheck calculations with 99% isopentane assumed to be conservative for emission estimates. *Please provide the information requested above as soon as possible, but no later than March 10, 2026.*

In regard to the alternative means of emission limitation (AMEL), I want to clarify that this is a compliance option under 40 CFR 60.112b(a)(4). The vapor balancing system does not meet the requirements associated with a closed vent system and control device under 40 CFR 60.112b(a)(3). The EPA has approved a similar vapor balancing system as an AMEL for Subpart Kb under [Docket ID EPA-HQ-OAR-2020-0599](#). This approval is specific to the facility which made the request. The Division does not have the authority to deem Amrize in compliance with Subpart Kb based on similar operating practices. Amrize will need to follow the process laid out in [40 CFR 60.114b\(c\)](#) to seek an AMEL. I must emphasize that the approval of any requested AMEL under Subpart Kb lies solely within the discretion of the EPA. In this case, "the Administrator" is the EPA. 40 CFR 60.117b(b) states that the authority of 40 CFR 60.114b is not delated to the States (KY DAQ). If the vessel is subject to Subpart Kc, there is a similar process for obtaining an AMEL, although control equivalent to a 98 percent emission reduction would need to be demonstrated.

Prior to approval of an AMEL, PRB does not believe Amrize will be in compliance with Subpart Kb. We can write the permit in such a way that upon approval, Amrize must follow the conditions set forth in the EPA's approval notice published in the Federal Register to demonstrate compliance with 40 CFR 60.112b(a)(4). Amrize would need to notify the Division of the approval, at which point we would determine whether any changes need to be incorporated into the permit. The Division cannot accept a 95% control efficiency for the vapor balancing system prior to approval of an AMEL. We will include a 90% control efficiency as a conservative estimate in line with [AP-42 Chapter 7.1](#) (see page 7.1-9) for the purposes of compliance with the sitewide emission limitation on VOC. The permit will contain operational and recordkeeping requirements relating to the vapor balancing system to demonstrate compliance with a 90% control efficiency on working losses. You will have the opportunity to review these requirements in a courtesy copy and during the public comment period. Please let me know if you have any questions.

Thanks,

Colby Freeman

Environmental Engineer Technologist I

Chemical Section
Division for Air Quality
300 Sower Blvd
Frankfort, KY 40601
(502) 782 - 1467

From: Burton JOYNER <burton.joyner@amrize.com>
Sent: Monday, March 2, 2026 2:46 PM
To: Freeman, Colby (EEC) <colby.freeman@ky.gov>
Cc: Jesse MEGENHARDT <jesse.megenhardt@amrize.com>; Ross, Dakota D (EEC) <dakota.ross@ky.gov>;
jeuler@decaenvironmental.com <jeuler@decaenvironmental.com>; Justin SMITH
<justin.smith2@amrize.com>; Harley, Brian (EEC) <Brian.Harley@ky.gov>
Subject: Re: Notice of Deficiency for AI 71732

****CAUTION** PDF attachments may contain links to malicious sites. Please contact the COT Service Desk ServiceCorrespondence@ky.gov for any assistance.**

Hi Colby,

I have attached the 7007J form(s) and the isopentane/acetone blend SDS as requested. After our discussion Thursday, we still concede the tank is subject to Subpart Kb, but it appears we may already be in full compliance with the rule's control requirements through vapor balancing. In light of this I have included two Routine Annual Emission reports: one that includes the use of the vapor balancing control, and one that does not account for that system. I have also included the output from both scenarios in the 7007J form. To summarize, with the vapor balance control in place, we have the PTE of 0.033% of the total pentane blend used annually compared to a PTE of 0.68% when the control is not accounted for.

Our Florence facility would like to claim and file for the AMEL exception to 40 CFR 60, Subpart Kb, specifically under 40 CFR 60.112b(a)(3) regarding the "use of a closed vent system and control device." As requested, I have included our current SOP for operator offload instructions.

Please let us know the next steps you would like us to take. We appreciate your willingness to help us understand and ensure complete compliance with all regulations.

Burton

On Thu, Feb 26, 2026 at 1:11 PM Freeman, Colby (EEC) <colby.freeman@ky.gov> wrote:

Burton,

Once you have determined the maximum throughput for the tank, please calculate potential emissions using EPA's [TANKS Emissions Estimation Software](#). I have linked you to the homepage for AP-42 Chapter 7 with the TANKS software highlighted. You can look into the other links if you have questions about any of the inputs. Specifically, we are looking for routine losses. TANKS can generate a PDF report which will provide all of the information we need for emissions.

We noticed the 7007J form listed a pentane/acetone mixture. This may require adding a custom organic liquid in TANKS to account for the mixture's vapor pressure. Please provide a material safety data sheet along with the 7007J form and emission calculations.

Here is the link to the docket for the alternative means of emission limitation we discussed today. You can find the facility's application and the EPA's approval conditions in the docket documents:

[AMEL](#)

Let me know if you have any questions. Thanks,

Colby Freeman

Environmental Engineer Technologist I
Chemical Section
Division for Air Quality
300 Sower Blvd
Frankfort, KY 40601
(502) 782 - 1467

From: Burton JOYNER <burton.joyner@amrize.com>
Sent: Wednesday, February 25, 2026 1:13 PM
To: Freeman, Colby (EEC) <colby.freeman@ky.gov>
Cc: Jesse MEGENHARDT <jesse.megenhardt@amrize.com>; Ross, Dakota D (EEC) <dakota.ross@ky.gov>; jeuler@decaenvironmental.com <jeuler@decaenvironmental.com>; Justin SMITH <justin.smith2@amrize.com>; Harley, Brian (EEC) <Brian.Harley@ky.gov>
Subject: Re: Notice of Deficiency for AI 71732

Thanks. I sent an invitation for tomorrow at 11AM eastern time.

On Wed, Feb 25, 2026 at 1:04 PM Freeman, Colby (EEC) <colby.freeman@ky.gov> wrote:

Burton,

We will be available from 10-12 tomorrow.

Thanks,

Colby Freeman

Environmental Engineer Technologist I
Chemical Section
Division for Air Quality
300 Sower Blvd
Frankfort, KY 40601
(502) 782 - 1467

From: Burton JOYNER <burton.joyner@amrize.com>
Sent: Wednesday, February 25, 2026 12:48 PM
To: Freeman, Colby (EEC) <colby.freeman@ky.gov>
Cc: Jesse MEGENHARDT <jesse.megenhardt@amrize.com>; Ross, Dakota D (EEC) <dakota.ross@ky.gov>; jeuler@decaenvironmental.com <jeuler@decaenvironmental.com>; Justin SMITH <justin.smith2@amrize.com>; Harley, Brian (EEC) <Brian.Harley@ky.gov>
Subject: Re: Notice of Deficiency for AI 71732

Hi Colby,

Would the DAQ PRB be agreeable to a call to review the DEP7007J form with Amrize's team? We have some questions and feel it would benefit us to talk it through to make sure we get you the information you need to issue the conditional permit. If so, I can set something up for tomorrow or Friday.

Thanks,

Burton

On Mon, Feb 23, 2026 at 2:41 PM Burton JOYNER <burton.joyner@amrize.com> wrote:

Hi Colby,

Please forgive my delay in reply. I have been consumed with environmental reporting for all of my locations. I do intend to fill out the requested form this week which should provide you with all the information you need. I will get it to you as soon as I can.

Thanks for your patience.

Burton

On Mon, Feb 23, 2026 at 2:04 PM Freeman, Colby (EEC) <colby.freeman@ky.gov> wrote:

Jesse,

I am following up on the tank emission estimate request below. The Division has determined the pentane storage vessel, as it currently stands and is operated by Amrize, is subject to 40 CFR 60, Subpart Kb. We plan to issue the draft renewal permit with the vessel listed in Section B of the permit along with all of the compliance options and applicable requirements of Subpart Kb. Tank information and emission estimates are necessary to declare the application complete and proceed with issuance of the permit. *Please provide this information as soon as possible, but no later than March 2, 2026.*

If Amrize believes the proposed method of compliance will exempt the tank from the requirements of Subpart Kb pursuant to the pressure vessel exemption at 40 CFR 60.110b(d) (2), this would need to be incorporated into the permit as a preclusion of Subpart Kb. After implementing the change, Amrize would need to submit a significant revision application. The Division would likely include monitoring and recordkeeping requirements to demonstrate the vessel is designed to operate in excess of 204.9 kPa and without emissions to the atmosphere, including during tank filling operations.

Thanks,

Colby Freeman

Environmental Engineer Technologist I

Chemical Section

Division for Air Quality

[300 Sower Blvd](#)

[Frankfort, KY 40601](#)

(502) 782 - 1467

From: Ross, Dakota D (EEC) <dakota.ross@ky.gov>
Sent: Monday, February 16, 2026 10:14 AM
To: Jesse MEGENHARDT <jesse.megenhardt@amrize.com>; Freeman, Colby (EEC) <colby.freeman@ky.gov>
Cc: jeuler@decaenvironmental.com <jeuler@decaenvironmental.com>; Justin SMITH <justin.smith2@amrize.com>; Burton JOYNER <burton.joyner@amrize.com>; Harley, Brian (EEC) <Brian.Harley@ky.gov>
Subject: RE: Notice of Deficiency for AI 71732

Thank you Jesse,

The Division will review and follow up if we have any questions.

In the meantime could you please provide a DEP 7007J form (<https://eec.ky.gov/Environmental-Protection/Air/Pages/Air-Permitting-Forms-and-Information.aspx>) for the tank and potential emission estimates for both how the tank is currently operating and how the tank will operate after the change using AP-42 Chapter 7.1 methodology/ EPAs Tanks 5.1 software.

Thanks,

Dakota Ross, P.E.

Environmental Engineer

Permit Review Branch

Division for Air Quality

[300 Sower Blvd](#)

[Frankfort, KY 40601](#)

(502) 782 - 6479

From: Jesse MEGENHARDT <jesse.megenhardt@amrize.com>
Sent: Friday, February 13, 2026 10:09 AM
To: Freeman, Colby (EEC) <colby.freeman@ky.gov>
Cc: jeuler@decaenvironmental.com; Justin SMITH <justin.smith2@amrize.com>; Burton JOYNER

<burton.joyner@amrize.com>; Ross, Dakota D (EEC) <dakota.ross@ky.gov>; Harley, Brian (EEC) <Brian.Harley@ky.gov>

Subject: Re: Notice of Deficiency for AI 71732

****CAUTION** PDF attachments may contain links to malicious sites. Please contact the COT Service Desk ServiceCorrespondence@ky.gov for any assistance.**

Dear Colby,

Please find attached our proposed solution and implementation plan to address the applicability of 40 CFR, Subpart Kb and the Notice of Deficiency of AL 71732.

Kindly acknowledge the receipt of this email. If you have any questions or concerns please do not hesitate to contact me.

Best Regards,

Jesse Megenhardt

Sr. Plant Manager

jesse.megenhardt@amrize.com

Amrize

[8170 Holton Drive, Florence, KY, USA, Florence, United States, 41042](#)

T: 41042, M: 5025250774

[Amrize](#) | [LinkedIn](#) | [Facebook](#)

This email is confidential and intended only for the use of the above named addressee. If you have received this email in error, please delete it immediately and notify us by email or telephone.

On Fri, Jan 9, 2026 at 10:29 AM Freeman, Colby (EEC) <colby.freeman@ky.gov> wrote:

Jesse,

The Division has received your response.

Thanks,

Colby Freeman

Environmental Engineer Technologist I

Chemical Section

Division for Air Quality

[300 Sower Blvd](#)

[Frankfort, KY 40601](#)

(502) 782 - 1467

From: Jesse MEGENHARDT <jesse.megenhardt@amrize.com>

Sent: Friday, January 9, 2026 10:13 AM

To: Freeman, Colby (EEC) <colby.freeman@ky.gov>

Cc: jeuler@decaenvironmental.com <jeuler@decaenvironmental.com>; Justin SMITH <justin.smith2@amrize.com>; Burton JOYNER <burton.joyner@amrize.com>; Ross, Dakota D (EEC) <dakota.ross@ky.gov>; Harley, Brian (EEC) <Brian.Harley@ky.gov>

Subject: Re: Notice of Deficiency for AI 71732

****CAUTION** PDF attachments may contain links to malicious sites. Please contact the COT Service Desk ServiceCorrespondence@ky.gov for any assistance.**

Dear Colby,

Please find the attached response regarding the potential applicability of 40 CFR 60, Subpart Kb and the Notice of Deficiency for AI 71732.

Kindly acknowledge receipt of this email.

Best Regards,

Jesse Megenhardt

Sr. Plant Manager

jesse.megenhardt@amrize.com

Amrize

[8170 Holton Drive, Florence, KY, USA, Florence, United States, 41042](#)

T: 41042, M: 5025250774

[Amrize](#) | [LinkedIn](#) | [Facebook](#)

This email is confidential and intended only for the use of the above named addressee. If you have received this email in error, please delete it immediately and notify us by email or telephone.

On Wed, Dec 10, 2025 at 7:55 AM Freeman, Colby (EEC) <colby.freeman@ky.gov> wrote:

Good morning,

Attached is the first Notice of Deficiency for the Conditional Major renewal application for Amrize Building Envelope LLC. This serves as your official copy and a paper copy will not be sent. We request that you submit the information as soon as possible, but in no case later than January 9, 2026.

Please feel free to contact me if you have any questions or need additional clarification.

Thanks,

Colby Freeman

Environmental Engineer Technologist I

Chemical Section

Division for Air Quality

[300 Sower Blvd](#)

[Frankfort, KY 40601](#)

(502) 782 - 1467

Routine Losses Report for TANKS 5.2

Storage Tank Emissions Calculation Application

Version 5.2

(released December 2025)

**U.S. Environmental Protection Agency
Office of Clean Air Programs
Natural Resources Division
Emissions Data and Assessment Branch
Research Triangle Park, NC 27711**

Report Contents

Accumulated Annual Routine Losses for All Tanks	3
Accumulated Monthly Routine Losses for All Tanks	4
For each tank and all tanks combined:	
• Standing Losses	
• Rim Seal Losses	
• Deck Seam Losses	
• Deck Fitting Losses	
• Working Losses	
• Total Routine Losses	
For each tank:	
• Tank Characteristics and Meteorological Location by Tank	
• Tank Contents by Tank	
• Tank Calculations by Tank	
• Fixed Roof Tanks	
• Routine Losses by Tank	
Appendices	
Custom Organic Liquids	11
Custom Petroleum Liquids	12
Custom Mixtures	14
Custom Meteorological Locations	15

Accumulated Annual Routine Losses for All Tanks

Tank ID	Standing Losses	Working Losses	Total Losses
FLO TK-01 - (Pentane Tank)	0	3,695.2715	3,695.2715
Total	0	3,695.2715	3,695.2715

Accumulated Monthly Routine Losses for All Tanks

Standing Losses

Tank ID	Chemical	Jan	Feb	Mar	Apr	May	Jun	Jul	Aug	Sep	Oct	Nov	Dec	Annual
FLO TK-01 - (Pentane Tank)	Isopentane / Acetone Mixture	0	0	0	0	0	0	0	0	0	0	0	0	0

Working Losses

Tank ID	Chemical	Jan	Feb	Mar	Apr	May	Jun	Jul	Aug	Sep	Oct	Nov	Dec	Annual
FLO TK-01 - (Pentane Tank)	Isopentane / Acetone Mixture	205.3068	220.5095	262.0638	315.5756	355.9941	384.3640	390.5147	389.5704	369.2818	318.7139	264.5954	218.7814	3,695.2715

Total Losses

Tank ID	Chemical	Jan	Feb	Mar	Apr	May	Jun	Jul	Aug	Sep	Oct	Nov	Dec	Annual
FLO TK-01 - (Pentane Tank)	Isopentane / Acetone Mixture	205.3068	220.5095	262.0638	315.5756	355.9941	384.3640	390.5147	389.5704	369.2818	318.7139	264.5954	218.7814	3,695.2715

Tank Characteristics and Meteorological Location by Tank

Identification

Tank ID	FLO TK-01 - (Pentane Tank)
Tank Type	Horizontal Fixed Roof Tank
Tank Description	80/20 Isopentane/Acetone Blend Storage Tank
City	Florence
State	Kentucky
Company	Amrize
Meteorological Location	Cincinnati, KY

Tank Characteristics

Shell Length (ft)	58
Shell Diameter (ft)	10
Maximum Liquid Height (ft)	9
Minimum Liquid Height (ft)	1
Vapor Space Pressure at Normal Operating Conditions (psig)	6
Is Tank Insulated or Underground?	Not Insulated and Not Underground
Liquid Bulk Temperature Calculation Method	AP-42 Calculation

Shell Characteristics

Shell Color/Shade	White
Shell Condition	Average

Breather Vent Settings

Vacuum Setting (psig)	-0.125
Pressure Setting (psig)	14.900

Control Device Settings

Is Tank Equipped with a Control Device?	Control Device
Control Device Type Efficiency	90

Tank Contents by Tank

Tank Contents Input Summary

Tank ID	FLO TK-01 - (Pentane Tank)
Input Type	Annual
Chemical Category of Liquid	Custom Organic Mixtures
Sum of Increases in Liquid Level Method	AP-42 Calculation
Working Loss Turnover Factor Method	AP-42 Calculation

Annual Contents

Mixture Name	Speciation Option	Components	Throughput (gal/yr)
Isopentane / Acetone Mixture	Partial Speciation	Acetone, Isopentane: (2-methyl butane)	4963067

Tank Calculations by Tank -- Fixed Roof

Tank ID: FLO TK-01 - (Pentane Tank)

Annual Calculations

Chemical: Isopentane / Acetone Mixture

Annual Vapor Space Volume (cu ft)	2,277.6547
Annual Avg. Vented Vapor Saturation Factor	0.3966
Vapor Space Outage (ft)	3.9270
Shell Radius (ft)	5
Annual Stock Vapor Density (lb/cu ft)	0.1002
Annual Avg. Vapor Molecular Weight (lb/lb-mole)	71.1537
Annual Avg. Vapor Pressure at Avg. Liquid Surface Temp. (psia)	7.8939
Annual Avg. Liquid Surface Temp. (°R)	515.9834
Annual Avg. Ambient Temp. (°R)	513.8408
Annual Avg. Liquid Bulk Temp. (°R)	494.4353
Tank Paint Solar Absorptance (Shell)	0.2500
Annual Avg. Vapor Space Expansion Factor	0
Annual Vapor Temp. Range (°R)	18.7908
Annual Vapor Pressure Range (psia)	1.6624
Breather Vent Pressure Setting Range (psia)	15.0250
Annual Avg. Vapor Pressure at Min Liquid Surface Temp. (psia)	7.0978
Annual Avg. Vapor Pressure at Max Liquid Surface Temp. (psia)	8.7602
Annual Avg. Min. Liquid Surface Temp. (°R)	511.2857
Annual Avg. Max. Liquid Surface Temp. (°R)	520.6811
Annual Avg. Ambient Temp. Range (°R)	17.8417
Annual Throughput (gal)	4963067
Annual Turnovers	11.9145
Annual Sum of Increases in Liquid Level (ft/yr)	1,143.7873
Working Loss Turnover Factor	1
Working Loss Product Factor	1

Tank ID: FLO TK-01 - (Pentane Tank)

Monthly Calculations

Chemical: Isopentane / Acetone Mixture

Calculation	Jan	Feb	Mar	Apr	May	Jun	Jul	Aug	Sep	Oct	Nov	Dec
Vented Vapor Saturation Factor	0.5284	0.5063	0.4511	0.3875	0.3409	0.3015	0.2875	0.2905	0.3245	0.3842	0.4482	0.5089
Stock Vapor Density (lb/cu ft)	0.0579	0.0627	0.0767	0.0973	0.1167	0.1375	0.1461	0.1442	0.1249	0.0986	0.0776	0.0621
Vapor Molecular Weight (lb/lb-mole)	71.2553	71.2400	71.2005	71.1515	71.1118	71.0748	71.0607	71.0638	71.0969	71.1488	71.1984	71.2418
Vapor Pressure at Avg. Liquid Surface Temp. (psia)	4.2877	4.6850	5.8472	7.5940	9.2901	11.1321	11.9046	11.7320	10.0013	7.7004	5.9159	4.6363
Avg. Liquid Surface Temp. (°R)	491.6601	495.3344	504.8039	516.5244	525.9994	534.8452	538.2129	537.4756	529.5663	517.1659	505.3148	494.8979
Avg. Ambient Temp. (°R)	490.7200	493.9200	502.8200	513.9200	522.9700	531.5200	534.9200	534.4700	527.1200	515.4200	504.2200	494.0700
Vapor Space Expansion Factor	0	0	0	0	0	0	0	0	0	0	0	0
Vapor Temp. Range (°R)	12.9150	15.4300	18.5050	21.5900	22.3500	22.8700	22.4950	22.0000	21.2650	18.9250	14.9100	12.2350
Vapor Pressure Range (psia)	0.6740	0.8650	1.2398	1.7826	2.1657	2.5565	2.6508	2.5628	2.1842	1.5796	1.0080	0.6800
Vapor Pressure at Min Liquid Surface Temp. (psia)	3.9614	4.2686	5.2536	6.7442	8.2572	9.9116	10.6371	10.5056	8.9563	6.9428	5.4291	4.3064
Vapor Pressure at Max Liquid Surface Temp. (psia)	4.6353	5.1336	6.4934	8.5268	10.4229	12.4681	13.2880	13.0684	11.1405	8.5224	6.4371	4.9864
Min. Liquid Surface Temp. (°R)	488.4314	491.4769	500.1777	511.1269	520.4119	529.1277	532.5892	531.9756	524.2501	512.4347	501.5873	491.8391
Max. Liquid Surface Temp. (°R)	494.8889	499.1919	509.4302	521.9219	531.5869	540.5627	543.8367	542.9756	534.8826	521.8972	509.0423	497.9566
Ambient Temp. Range (°R)	14.5000	16.1000	18.1000	19.9000	19.2000	18.7000	18.3000	18.8000	20.1000	19.7000	16.7000	14
Throughput (gal/mo)	413,588.9167	413,588.9167	413,588.9167	413,588.9167	413,588.9167	413,588.9167	413,588.9167	413,588.9167	413,588.9167	413,588.9167	413,588.9167	413,588.9167
Sum of Increases in Liquid Level (ft/mo)	95.3156	95.3156	95.3156	95.3156	95.3156	95.3156	95.3156	95.3156	95.3156	95.3156	95.3156	95.3156
Working Loss Product Factor	1	1	1	1	1	1	1	1	1	1	1	1

Supplemental Non-Monthly Data

Vapor Space Volume (cu ft)	2,277.6547
Effective Diameter (ft)	27.1750
Vapor Space Outage (ft)	3.9270
Liquid Bulk Temp. (°R)	494.4353
Tank Paint Solar Absorptance (Shell)	0.2500
Breather Vent Pressure Setting Range (psia)	15.0250
Turnovers	11.9145
Working Loss Turnover Factor	1

Routine Losses by Tank

Tank ID: FLO TK-01 - (Pentane Tank)

Annual Routine Losses

Chemical	Standing Losses	Working Losses	Total Losses
Isopentane / Acetone Mixture	0	3,695.2715	3,695.2715

Total Annual Component Losses

Acetone	216.9260
Isopentane: (2-methyl butane)	3,478.3455

Tank ID: FLO TK-01 - (Pentane Tank)

Monthly Routine Losses

Chemical: Isopentane / Acetone Mixture

Loss Type	Jan	Feb	Mar	Apr	May	Jun	Jul	Aug	Sep	Oct	Nov	Dec
Standing Losses	0	0	0	0	0	0	0	0	0	0	0	0
Working Losses	205.3068	220.5095	262.0638	315.5756	355.9941	384.3640	390.5147	389.5704	369.2818	318.7139	264.5954	218.7814
Total Losses	205.3068	220.5095	262.0638	315.5756	355.9941	384.3640	390.5147	389.5704	369.2818	318.7139	264.5954	218.7814

Total Monthly Component Losses

Component	Jan	Feb	Mar	Apr	May	Jun	Jul	Aug	Sep	Oct	Nov	Dec
Acetone	10.6417	11.6274	14.4259	18.2806	21.4533	24.0022	24.7111	24.5804	22.5791	18.5128	14.5985	11.5130
Isopentane: (2-methyl butane)	194.6650	208.8821	247.6378	297.2950	334.5408	360.3619	365.8036	364.9900	346.7027	300.2012	249.9969	207.2684

Custom Organic Liquids

Chemical Name	Molecular Weight	Liquid Density (lb/gal)	Antoine's Equation Constant A	Antoine's Equation Constant B (deg C)	Antoine's Equation Constant C (deg C)
---------------	------------------	-------------------------	-------------------------------	---------------------------------------	---------------------------------------

Custom Petroleum Liquids

Chemical Name	Vapor Molecular Weight (lb/lb-mol)	Liquid Molecular Weight (lb/lb-mol)	Liquid Density (lb/gal)	Vapor Pressure Equation Constant A	Vapor Pressure Equation Constant B (*R)
---------------	------------------------------------	-------------------------------------	-------------------------	------------------------------------	---

Mole Fractions

Petroleum Liquid Name	Component Chemical Name	Component Mole Fraction Type	Component Mole Fraction
-----------------------	-------------------------	------------------------------	-------------------------

Custom Mixtures

Mixture Name	Component Chemical Name	Component Liquid Mole Fraction
Isopentane / Acetone Mixture		
	Acetone	0.2
	Isopentane: (2-methyl butane)	0.8

Custom Meteorological Locations

Location Name	Month	Avg. Max. Ambient Temp. (deg F)	Avg. Min. Ambient Temp. (deg F)	Avg. Wind Speed (mph)	Avg. Daily Total Insolation Factor (Btu/ft2/day)	Avg. Atmospheric Pressure (psi)
---------------	-------	---------------------------------	---------------------------------	-----------------------	--	---------------------------------



Trecora Hydrocarbons LLC
P.O. Box 1636
Silsbee, Texas 77656

CERTIFICATE OF ANALYSIS

CERTIFICATE OF ANALYSIS FOR TRECORA™ IPAC100

LOT # *022685226
TANK # utlx212374

	<u>Specification</u>	<u>ANALYSIS</u>
ISOPENTANE, WT% by G.C.	MIN 80.0 MAX 83.0	81.3
ACETONE, WT%	MIN 18.0 MAX 21.0	18.7
n-PENTANE, wt% by G.C.	Report	<0.01
Total Sulfur, WPPM, ASTM D5453	MAX 2.0	<0.1
SPECIFIC GRAVITY	Report	0.6470
API GRAVITY	Report	87.2
DENSITY Lbs/GAL.	Report	5.385
WATER, PPMW, ASTM D6304	Report	Report

* Denotes test which are performed quarterly by either an outside, certified laboratory or Trecora's QAL.

ADDITIONAL ANALYSIS

SPECIFIC GRAVITY 0.6470
API GRAVITY 87.2
DENSITY lbs/GAL. 5.385

CUSTOMER _____

PO # _____

TRANSPORTATION MODE _____

DATE SHIPPED _____

SPQC DEPARTMENT SIG. _____

C OF A APPROVAL DATE _____ *02/26/26

Telephone 409.385.8300

Fax 409.385.2453

Instructions for Proposed Modification Log

Date of Request	Indicate the date that the proposed modification was entered on the log
Name of Person Requesting Modification	Enter the name of the person requesting the modification - this will be the contact if additional information is needed
Description of Proposed Modification	Briefly describe the proposed modification
Plant Equipment Involved in Proposed Modification	Describe the plant equipment that may be affected by this proposed change
Is this proposed modification a replacement in kind?	Replacement in kind is defined as a replacement which satisfies the design specifications. If yes, no further action may be necessary for this proposed modification. If no, continue evaluation with the Hazard Category Matrix
Approval by PS/RM Coordinator	Obtain approval from PS/RM Coordinator

Attachment 11-2

Hazard Category Matrix Worksheet

Hazard Category Matrix

Degree of Hazard

1. Does the change introduce or affect a significant source of potential chemical, mechanical, thermal or electrical energy? Yes or No
2. Does the change result in any increase in inventory of pentane? Yes or No
If Yes, by what percent will the inventory increase _____%
3. Does the change significantly increase the potential for personal exposure to pentane? Yes or No
4. Is there a safety standard (e.g. OSHA, API, Electric Code) associated with the process system undergoing the change? Yes or No

Two or more Yes answers or a hazardous inventory increase of 25% or greater equals a HIGH Degree of Hazard.

Significance of Change

1. Could the change take the process outside previous limits of normal operation (that is, outside the well-understood "safe operating range")? Yes or No
2. Does the change introduce new material(s) to the process? Yes or No
3. Does the change alter the processing sequence? Yes or No
4. Does the change significantly impact the energy balance or material balance of the process? Yes or No
5. Does the change alter, affect or bypass a safety device or critical control system? Yes or No
6. Does the change necessitate significant or unique training for Operators or Technical personnel? Yes or No

A Yes answer to Question 1 or Question 2 or Yes answers to any other two questions equals a HIGH significance of change.

Significance of Change

Degree of Hazard

	Low	High
Low	Level A	Level B
High	Level C	Level D

Hazard Category Level of Change	Type of MOC	Authorization
A	MOC Form	PS/RM Coordinator
B	MOC Form with What-If Checklist (one node)	PS/RM Coordinator
C	MOC Form with What-If Checklist (several nodes)	PS/RM Coordinator and Plant Manager
D	MOC Form and revalidate PHA with What-If Checklist (all six nodes)	PS/RM Coordinator and Plant Manager

*Attachment 11-3
Management of Change Form and Instructions*

Management of Change Form

PS/RM
Coordinator Charlie Roberts Date: 7-27-2022

1. Type of Change: (check all that apply)
- Process Equipment/Material Modification
 - Electrical
 - Temporary
 - Process Condition Modification
 - Operating Procedure Modification
 - _____

2. Hazard Category Level: Level A Level B Level C Level D

3. Description of Proposed Modification including schedule and technical basis for change:

Go from 100% pentane blowing agent to an 80% pentane 20% acetone blend. Planned change over time is 8/1/2022. New formulation for our ISO process.

If Proposed Modification is temporary, how long will change exist?

NO

Complete Table 1 MOC Evaluation Process
Complete the Action Item Description column for all "Yes" responses
Track progress of all defined Action Items in PSM Action Item Tracking Log
No Further Action is necessary for items with "No" response

MOC Evaluation

Requirement	Evaluation of Requirement	No*	Yes**	Action Item
Employee Training and Awareness	Are employees job tasks affected by this change? If "yes", document training with employees		✓	SDS training for all teammates
Contractor Training and Awareness	Are contract employees job tasks affected by this change? If "yes", document training	✓		
Review of Operating Procedures	Do the operating procedures associated with the process or maintenance of this process require modification due to this change? If "yes", update procedures and train affected personnel	✓		
Process Hazard Analysis	Is a PHA review or revalidation required? Mark "no" if Hazard category is determined as Level A. Mark "yes" if hazard category is determined as Level B, C or D. If "yes", complete PHA review/revalidation		✓	Reviewed PHA Node (1-3) 7/27/22
Inspection and Testing Requirements	Are there any new or modified inspection and testing requirements as a result of this change? If "yes", incorporate requirements into the mechanical integrity program (specify frequency and written procedures)	✓		
Process Safety Information	Do the Process Flow Diagrams require modification due to this change?	✓		
	Do the Piping and Instrumentation Diagrams require modification due to this change?	✓		
	Does the electrical classification of the process require modification due to this change?	✓		
	Does any new covered process equipment need to be added to the Process Safety Information table OR does any of the equipment listed need to be modified?	✓		

Pre-Start Up Safety Review	<p>Is a Pre-Start Up Safety Review required? Mark "yes" if any one item under Process Safety Information are marked "yes". Mark "no" if all four items under Process Safety Information are marked "no"</p> <p>If "yes", complete a field review of the change and complete the New and Modified Equipment Checklist</p>			
----------------------------	--	--	--	--

*No further action is necessary for items marked "No"

**Complete the Action Item section for items marked "Yes" and track action items using the PSM Action Item Tracking Log

Approvals

Plant Manager:

Dyane Mezenhardt

Date: 8/1/22

Safety Manager:

[Signature]

Date:

Maintenance Supervisor:

[Signature]

Date: 7/27/22

Plant

Superintendent/Production
Supervisor:

[Signature]

Date: 7-27-22

Minimum of three signatures required

MOC Meeting attendees:

Chad Roberts

Matt Holloway

Ben Freeman

Nick Vandergast

Tim Carter

INSTRUCTIONS - MANAGEMENT OF CHANGE FORM

PS/RM Coordinator

Print your name and the date that the form is initiated.

Check all boxes in "TYPE OF CHANGE" which apply. Since this form is used for all types of facility process change, there may be a need to use the space provided to write a different type of change.

1. Briefly describe the change with reasonable technical detail concerning the basis of change. Attach drawings, vendor information or other instructive information to the form for other reviewers, if appropriate.
2. State the date on which you wish the change to become functional. If the change is temporary, be sure to include the length of time for which this change should be authorized.
3. Complete MOC Evaluation Form
4. Identify any Action Items from the MOC Evaluation and track on the PSM Action Item Tracking Log.

Reviewers

1. After reviewing the MOC Form and Evaluation, determine if you agree with the change and evaluation. If yes, complete the appropriate approval signature line. If no, review proposed modification and action items with PS/RM Coordinator, the PSM Committee, and/or the Division Safety/Environmental Managers.



Re: AI 71732 - Amrize Building Envelope, LLC - Courtesy Copy and RO Additional Information Request

From Burton JOYNER <burton.joyner@amrize.com>

Date Wed 4/1/2026 2:38 PM

To Freeman, Colby (EEC) <colby.freeman@ky.gov>

Cc Jesse MEGENHARDT <jesse.megenhardt@amrize.com>; jeuler@decaenvironmental.com <jeuler@decaenvironmental.com>; Harley, Brian (EEC) <Brian.Harley@ky.gov>; Bittner, Zachary P (EEC) <Zachary.Bittner@ky.gov>; Justin SMITH <justin.smith2@amrize.com>

1 attachment (403 KB)

Amrize Building Envelope, LLC - Delegation of Authority Letter.pdf;

****CAUTION** PDF attachments may contain links to malicious sites. Please contact the COT Service Desk ServiceCorrespondence@ky.gov for any assistance.**

This Message Originated from Outside the Organization

This Message Is From an External Sender.

Report Suspicious

Hi Colby. Thanks for the draft. We will review the draft and get back to you as needed.

Attached is the delegation of authority letter. Please let me know what else you need.

On Wed, Apr 1, 2026 at 11:03 AM Freeman, Colby (EEC) <colby.freeman@ky.gov> wrote:

Please find attached a courtesy copy of the renewal Conditional Major Operating Permit for Amrize Building Envelope, LLC. Please submit any written comments or questions no later than April 8, 2026, so that the Division may continue processing the permitting action. Any submitted questions and comments will be part of the public permitting record and considered disclosable under the Kentucky Open Records Act. Be advised that the permit may differ from the attached even if there are no questions or comments as the permit package will undergo additional internal reviews and approvals.

Additionally, we need to confirm whether Jesse Megenhardt has authority as a responsible official (RO) as defined in [401 KAR 52:001 Section 1\(62\)](#), as we do not have a delegation request on file, and they do not appear to meet the definition by default. Mr. Megenhardt's title does seem like they could be a delegated authority, but that delegation request letter must come from someone who is an RO without delegation (president, secretary, treasurer, or vice-president of the corporation in charge of a principal business function, or other person who performs similar policy or decision-making functions for the corporation). We will need a delegation letter, or confirmation that Mr. Megenhardt performs similar policy or decision-making functions *for the corporation*, before proceeding with issuance of the draft permit.

Please let me know if you have any questions.

Colby Freeman

Environmental Engineer Technologist I

Chemical Section

Division for Air Quality

300 Sower Blvd

Frankfort, KY 40601

(502) 782 - 1467

AMRIZE BUILDING ENVELOPE LLC

SECRETARY'S CERTIFICATE

The undersigned, Robert P. Sweeter, hereby certifies that he is the duly elected and acting Assistant Corporate Secretary of Amrize Building Envelope LLC, an Indiana limited liability (the "**Company**"), and that, as such, he is duly authorized to execute and deliver this Secretary's Certificate on behalf of the Company, and in his capacity as Assistant Corporate Secretary of the Company and not individually, does hereby certify as follows:

Attached hereto as Exhibit A is a true, correct and complete copy of Section 5.2(f) of the Company's Third Amended and Restated Limited Liability Agreement (the "**LLC Agreement**"). Such LLC Agreement has not been further amended or modified and is in full force and effect on the date hereof in the form adopted.

Attached hereto as Exhibit B is a true, correct and complete copy of an Amended Delegation of Authority from Ganesh Nayakwadi in capacity as Chief Financial Officer of the Company to the various managers of the Company as set forth thereon as effective on June 23, 2025.

IN WITNESS WHEREOF, the undersigned has executed this Secretary's Certificate on behalf of the Company effective the 23rd day of June 2025.

AMRIZE BUILDING ENVELOPE LLC

DocuSigned by:
By Robert Sweeter
830C641FBDC3496...

Name: Robert Sweeter

Title: Assistant Corporate Secretary

EXHIBIT A

**THIRD AMENDED AND RESTATED
LIMITED LIABILITY COMPANY AGREEMENT
OF
AMRIZE BUILDING ENVELOPE LLC
(an Indiana limited liability company)**

Effective as of June 20, 2025

THE UNITS REPRESENTED BY THIS LIMITED LIABILITY COMPANY AGREEMENT HAVE NOT BEEN REGISTERED UNDER THE UNITED STATES SECURITIES ACT OF 1933, AS AMENDED, OR UNDER ANY OTHER APPLICABLE FEDERAL OR STATE SECURITIES LAWS. SUCH UNITS MAY NOT BE SOLD, ASSIGNED, PLEDGED OR OTHERWISE DISPOSED OF AT ANY TIME WITHOUT EFFECTIVE REGISTRATION UNDER SUCH ACT AND LAWS OR EXEMPTION THEREFROM, AND COMPLIANCE WITH THE OTHER RESTRICTIONS ON TRANSFER SET FORTH HEREIN.

Days prior to the date of such meeting; or (ii) given by hand, electronic transmission (including e-mail), telecopy or telephone to each Manager at least twenty-four (24) hours prior to the date of such meeting. Except as required by the Act, notices of a regular or special meeting of the Board need not specify the purpose for which the meeting is called and the failure to identify any action to be taken or business to be transacted will not invalidate any action taken or any business transacted at a meeting of the Board.

(e) **Location of Meetings.** Meetings of the Board may be held at any location within or without the United States. Managers may participate in a meeting of the Board by telephone conference, video conference or other methods of communication by which all Persons participating in the meeting can hear each other, and such participation in a meeting will constitute presence in person at the meeting.

(f) **Waiver of Notice of Meeting.** Whenever notice of a meeting of the Board is required to be given under this Agreement, a written waiver of notice signed by a Manager, whether before or after the time of the meeting, will constitute due notice to that Manager. A Manager's attendance at a meeting of the Board will constitute a waiver of notice of that meeting, except when the Manager attends a meeting for the express purpose of objecting, at the beginning of the meeting, to the transaction of any business because the meeting is not lawfully called or convened.

(g) **Quorum for Meetings.** A majority of the Managers will constitute a quorum for the transaction of business at a meeting of the Board. In the absence of a quorum, the Chairman of the Board (to the extent the Company has such designated officer position) or a majority of the Managers present may adjourn such meeting until a quorum shall be present. Notice of any adjourned meeting need not be given.

(h) **Required Vote.** The vote of at least a majority of the Managers present at a meeting at which a quorum is present will constitute approval by, or the authorization of, the Board.

(i) **Voting; No Proxies.** Each Manager will have one vote. A Manager will not have the power to authorize another Person to vote on his or her behalf by proxy or otherwise.

(j) **Written Actions.** Any action required or permitted to be taken at any meeting of the Board or of any committee thereof may be taken without a meeting, without prior notice and without a vote, if, before or after such action, a majority of the Managers or committee members, as the case may be, consent thereto in writing or by electronic transmission.

(k) **Committees.** The Board may designate one or more committees of the Board, each consisting of two (2) or more Managers, and delegate any or all of its powers and authority to any such committee. The Board may change the members of any committee, fill vacancies, and discharge any committee, either with or without cause, at any time. Except to the extent inconsistent with the resolutions creating a committee, the provisions of Sections 5.1(e) — (k) of this Agreement apply to each committee and its members as well, except that special meetings of any such committee may be called by any member of the committee.

5.2 Officers.

(a) **Offices and Election of Officers.** The officers of the Company (collectively, the “**Officers**” and each “**Officer**”) will be appointed by the Board, and the Board may create or eliminate offices from time to time as the Board deems appropriate. Any number of offices may be held by the same Person.

(b) **Term, Resignation and Removal of Officers.** Each Officer will hold office until his or her successor is elected and qualified or until his or her earlier death, resignation or removal. Any Officer may be removed at any time, with or without cause, by the Board. Nothing in this Agreement shall limit the power of any Officer to discharge any subordinate. Any Officer may resign at any time by delivering his or her resignation to the Board.

(c) **Duties, Responsibilities, Powers and Authority of Officers.** Unless otherwise expressly stipulated by the Board, and subject to the limitations set forth in Section 5.2(e) of this Agreement, the Officers of the Company will have such duties, responsibilities, powers and authority as are customary for officers of a corporation holding the same or similar offices (the “**Customary Duties and Powers**”) and shall have such additional duties, responsibilities, powers and authority as may be delegated to the Officers by the Board from time to time. The Board may establish, increase, reduce or otherwise modify the duties, responsibilities, powers and authority of any or all Officers from time to time. Notwithstanding anything in this Agreement to the contrary, all powers and authority granted to each Officer by this Agreement or resolution of the Board (unless such resolutions explicitly states otherwise) shall be subject to any required procedures and approvals (including any approvals required by any Financial Authority Schedule or similar policy) adopted by the Board from time to time.

(d) **General Powers.** All Officers, except Assistant Secretaries and Assistant Controllers, are, in addition to the Customary Duties and Powers applicable to such Officer positions, authorized and empowered to execute and deliver in the name and on behalf of the Company (i) bids, contracts, agreements, licenses, assignments and other documents with any Person; (ii) patent and trademark applications; (iii) bonds or contracts of surety required by any Person with respect to bids, contracts, agreements and performance of contracts by the Company and/or its subsidiaries; and (iv) applications of any sort to any Governmental Authority for any permit or authority to act that may be required by such entity for the conduct of its business or any aspect thereof by the Company. This Section 5.2(d) does not apply to, and does not grant any Officer authority to, execute or deliver contracts relating to the compromise of suits and claims by or against the Company; the guaranty of present or future indebtedness of any other Person; the sale, purchase or voting of securities; the opening or closing of bank accounts; or the borrowing of money.

(e) **Specific Powers.** The officer positions described below shall have, in addition to the Customary Duties and Powers applicable to such officer positions, the specific powers and authority granted to such officer positions in this Section 5.2(e) as well as the authority to perform all such acts and execute and deliver such documents as are necessary to exercise such powers and authority. No Officer may exercise, and the Customary Duties and Powers of each Officer shall not include, any of the powers or authority granted in this Section 5.2(e) unless such power or authority is specifically granted or delegated to such Officer or such Officer’s position by (i) this Section 5.2(e), (ii) Board resolution, or (iii) an Officer who possesses such powers and authority.

(i) Chairman, Chief Executive Officer and President. If, and to the extent, the Company has such designated officer positions, the Chairman, Chief Executive Officer and President shall be authorized to:

1. subscribe, purchase, acquire, sell, assign, or Transfer on behalf of the Company stock or other equity interests or securities in any other Person (“**Equity Interests**”), whether issued in the name of the Company or any subsidiary or division of the Company; and

2. exercise all the rights and powers of the Company with respect to all Equity Interests in which the Company has any right, title or interest, including without limitation, voting such Equity Interests or representing the Company at any meeting of the equity holders and authorizing, executing and delivering written consents, waivers of notice of a meeting, proxies, powers of attorney or delegations.

(ii) Chief Executive Officer, President, Chief Financial Officer, Treasurer and Controller. If, and to the extent, the Company has such designated officer positions, the Chief Executive Officer, President, Chief Financial Officer, Treasurer and Controller shall be authorized to make, enter into, execute and deliver any agreements, instruments and documents in the name and on behalf of the Company whereby the Company borrows money, assumes indebtedness or guarantees the payment of indebtedness of another Person.

(iii) General Counsel. If, and to the extent, the Company has such designated officer positions, the General Counsel shall be authorized to appoint attorneys; institute legal proceedings, authorize the commencement, defense, compromise, settlement, or other termination of legal proceedings to which the Company is a party and to grant power or powers of attorney to Persons to represent the Company in all legal matters and affairs including but not limited to the handling of all of the Company’s patents and trademarks. Such power or powers of attorney may include the powers and faculties to (i) appear and represent the Company before any Governmental Authority; (ii) prepare and file all applications, petitions, complaints, pleadings, and all related legal documents, and to handle and conduct to their final conclusion, including appeals, all legal actions and matters in which the Company is a party; and (iii) to initiate, prosecute, and defend any and all litigation and generally to act with respect to any and all legal matters pertaining to the rights, privileges, and interests of the Company, and generally to do and perform all and every act and thing whatsoever requisite, necessary, and proper to be done to represent and act for and on behalf of the Company.

(f) ***Delegation of Authority.*** Any Officer or employee who is authorized by this Agreement or the Board to exercise on behalf of the Company any of the powers set forth in this Agreement, including any Customary Duties and Powers, or in any Board resolutions may delegate to Persons responsible to him or her (directly or indirectly) authority to exercise any or all such powers.

(g) ***Delegation by Resolution.*** The Board may, by resolution, designate other Officers, employees or other Persons to exercise such powers on behalf of the Company as such resolutions shall specify.

EXHIBIT B

**AMRIZE BUILDING ENVELOPE LLC
AMENDED DELEGATION OF AUTHORITY**

TO: 45 Individual Managers and Executives

FROM: Ganesh Nayakwadi, Chief Financial Officer

EFFECTIVE: June 23, 2025

In my capacity as Chief Financial Officer of Amrize Building Envelope LLC (the "**Company**"), I am authorized and empowered by Section 5.2(f) of the Company's Third Amended and Restated Limited Liability Company Agreement as follows:

"(f) **Delegation of Authority.** Any Officer or employee who is authorized by this Agreement or the Board to exercise on behalf of the Company any of the powers set forth in this Agreement, including any Customary Duties and Powers, or in any Board resolutions may delegate to Persons responsible to him or her (directly or indirectly) authority to exercise any or all such powers."

Pursuant to the provision mentioned above, I hereby delegate to the following individuals my authority to execute and file environmental filings on behalf of the Company, including, without limitation, applications, permits, reports, certificates, and other documents relating to compliance with environmental laws and regulations:

1. Thomas Apostolos – Vice President of Operations
2. Mike Lee – Vice President of Operations, Ox Engineered Products
3. Kevin G. Bretz, PE - Executive Director, Environmental, Health & Safety, and Sustainability
4. Ullrich Wolf – Head of Manufacturing for Gaco and Enverge
5. Mike Davis – Plant Manager, Charleston, IL
6. Tim Scarpinato – Plant Manager, Ox Engineered Products Jacksonville, FL
7. Chad Parmer – Plant Manager, Constantine, MI
8. Paul Haage – Plant Manager, Garden Grove, CA
9. Eve Law – Plant Manager, Rockland, MA
10. Dante Moore – Plant Manager, Houston, TX & Norcross, GA
11. Craig Markham – Plant Manager, Waukesha, WI
12. John Giglotti – Plant Manager, Spring, TX
13. Dwayne Stephens – Plant Manager, Wellford, SC
14. David LeSieur – Plant Manager, Prescott, AR
15. Robert Latter - Plant Manager, Muscle Shoals, AL
16. Michael Simmons – Plant Manager, Anoka MN
17. Robert Iosue - Distribution Center Manager, Mt. Joy, PA
18. Cindy Henderson – Plant Manager, Elevate Jacksonville, FL

19. Alexander Smith – Plant Manager, Salt Lake City, UT
20. Gregory Stephens – Plant Manager, Deforest, WI
21. Charlie Roberts – Plant Manager, Beech Grove, IN
22. Jesse Megenhardt – Plant Manager, Florence, KY
23. Joseph Standeford – Plant Manager, Corsicana, TX
24. Mathias Meier – Plant Manager, Youngwood, PA
25. Michael Gullotta – Plant Manager, Bristol, CT
26. Timothy Berry – Senior Plant Manager, Waukesha, WI
27. John Aidoo – Manager, Manufacturing Operations
28. Kari Hahn – DL Plant Manager, Sigourney, IA
29. Glen Sullivan – DL Plant Manager, Ludlow, MA
30. Brandon Boelter – DL Plant Manager, Saginaw, MI
31. John Glasscock – DL Plant Manager, Grants Pass, OR
32. James Shoquist – DL Plant Manager, Carrollton, TX
33. Chris Williams – DL Plant Manager, Jackson, MS
34. Joe Hyde – DL Plant Manager, Kernersville, NC
35. Paul Kauffman – Tip Top Screws Plant Manager, Oscoda, MI
36. Scott Craven – Plastatech Plant Manager, Saginaw, MI
37. Dave Wade – Anvil Plant Manager, Largo, FL
38. DJ Decker – Oscoda Plastics Plant Manager, Oscoda, MI
39. Dave Berry – Exceptional Metals Plant Manager, Saginaw, MI
40. Preston Butler – Plant Manager, Spring, TX
41. Robert Yrigoyen - Plant Manager, Tucson, AZ

Additionally, I hereby make a limited delegation of my authority to execute and file environmental filings on behalf of the Company, to the extent that such environmental filings do not require the signature or certification of a “Responsible Official” or “Responsible Corporate Officer”.

42. Erica Mikulecky – Director EHS
43. James House – Director EHS
44. Chad Hopkins – Director EHS
45. Justin Smith - Corporate Environmental Manager

This authority delegated to you pursuant to this delegation may not be further delegated by you. Such delegated authority will continue in effect until modified or revoked in writing or until you are no longer employed by the Company, whichever shall first occur. This amended delegation of authority supersedes and replaces any prior delegations related to authority to execute and file environmental filings on behalf of the Company.

[Signature appears on the following page]

AMRIZE BUILDING ENVELOPE LLC

Signed by:
By: *Ganesh Nayakwadi*
FDB2526A574944C...

Name: Ganesh Nayakwadi

Title: Chief Financial Officer

Freeman, Colby (EEC)

From: Burton JOYNER <burton.joyner@amrize.com>
Sent: Monday, April 20, 2026 11:04 AM
To: Freeman, Colby (EEC)
Cc: Jesse MEGENHARDT; jeuler@decaenvironmental.com; Harley, Brian (EEC); Bittner, Zachary P (EEC); Justin SMITH; Ross, Dakota D (EEC)
Subject: Re: AI 71732 - Amrize Building Envelope, LLC - Courtesy Copy and RO Additional Information Request

This Message Originated from Outside the Organization

This Message Is From an External Sender.

[Report Suspicious](#)

Good morning Colby et al,

Here is a primer list for our discussion tomorrow.

1. Can you explain the regulatory or requirement changes that made this draft air permit significantly more stringent than those issued over the facility's last 20+ years of operation?

For example but not limited to: a) testing requirements specifically for isopentane and acetone analytes compared to blanket VOCs; b) SCAQMD method 306-91 to analyze the isopentane content of freshly cut samples; c) inclusion of explicit mathematical equations to determine CE and VOC emissions; d) a mandate to use provided tables to assign specific control efficiency, PM emissions factors, and VOC emissions factors to every individual emission unit and process ID at the facility; and e) stretch wrap requirements on finished boards, a mandate to limit the movement of wrapped boards waiting for shipment and instructions to provide SOPs for these practices.

2. EU-IA2 The proposed permit lists a Sulfur Dioxide SO₂ emission limit of 2.98 lb/MMBtu. The existing permit lists this limit as 3.0 lb/MMBtu. Why is the number changed in the current renewal?

3. The proposed permit specifies a 22.572 lb/ton emission factor for EU-01, opposed to the old permit, which calculates PM emissions using the formula ($E = 3.59 P^{0.62}$). This seems abnormally high and could cause us to exceed our 90-ton annual limit prematurely. Under 401 KAR 59:010 Section 3(2), a process with a capacity of 8 tons/hr (16,000 lbs/hr) is limited to 13.03 lbs/hr. Where did this 22.572 lb/ton emission factor come from?

4. Can we use the proven 99.5% control efficiency for record keeping of the actual emissions?

5. We request the removal of the following Emission Units from Section D and to lower the 90 ton actual limit. This would help Amrize reduce tracking while maintaining compliance without undue focus on insignificant activities.

FUG05 (1)

FUG05 (2)

IA1A (1)

IA1B (1)

IA2(1)

IA4B (1)

IA4C (1)

IA4D (1)

IA5 (1)

IA5 (2)

IA6 (1)
IA6 (2)
IA7 (1)

6. You were copied on the EPA AMEL request. For the TK-01 requirements, will they remain the same or become unnecessary if the EPA AMEL request is allowed?

7. We can also explore having your team visit the facility to gain perspective on actual plant operations beyond a paper exercise.

Looking forward to our discussion tomorrow.

On Wed, Apr 15, 2026 at 3:31 PM Burton JOYNER <burton.joyner@amrize.com> wrote:
Absolutely, Colby. Thank you. I will check everyone's schedule and find a time on Tuesday to meet with you.

We plan to meet as a group on Friday and I will send out a list for your review soon after.

Thanks again.

On Wed, Apr 15, 2026 at 2:23 PM Freeman, Colby (EEC) <colby.freeman@ky.gov> wrote:
Burton,

We are available to meet on Tuesday between 10 and 1 Eastern. Could you provide a list of the main items you would like to discuss by Monday?

Thanks,

Colby Freeman

Environmental Engineer Technologist I
Chemical Section
Division for Air Quality
300 Sower Blvd
Frankfort, KY 40601
(502) 782 - 1467

From: Burton JOYNER <burton.joyner@amrize.com>
Sent: Monday, April 13, 2026 5:19 PM
To: Freeman, Colby (EEC) <colby.freeman@ky.gov>
Cc: Jesse MEGENHARDT <jesse.megenhardt@amrize.com>; jeuler@decaenvironmental.com
<jeuler@decaenvironmental.com>; Harley, Brian (EEC) <Brian.Harley@ky.gov>; Bittner, Zachary P (EEC)
<Zachary.Bittner@ky.gov>; Justin SMITH <justin.smith2@amrize.com>
Subject: Re: AI 71732 - Amrize Building Envelope, LLC - Courtesy Copy and RO Additional Information Request

Hi Colby,

If possible, I'd like a little more time to ask some questions about the permit. I was OOO all last week with a family matter and really didn't get a good look at the draft until today. We need to discuss it as a

larger group but I know we'll have some questions around the monitoring requirements for the TK-01. Is it possible to talk with your team early next week?

Thanks for your consideration.

Burton

On Wed, Apr 1, 2026 at 2:35 PM Burton JOYNER <burton.joyner@amrize.com> wrote:
Hi Colby. Thanks for the draft. We will review the draft and get back to you as needed.

Attached is the delegation of authority letter. Please let me know what else you need.

On Wed, Apr 1, 2026 at 11:03 AM Freeman, Colby (EEC) <colby.freeman@ky.gov> wrote:
Please find attached a courtesy copy of the renewal Conditional Major Operating Permit for Amrize Building Envelope, LLC. Please submit any written comments or questions no later than April 8, 2026, so that the Division may continue processing the permitting action. Any submitted questions and comments will be part of the public permitting record and considered disclosable under the Kentucky Open Records Act. Be advised that the permit may differ from the attached even if there are no questions or comments as the permit package will undergo additional internal reviews and approvals.

Additionally, we need to confirm whether Jesse Megenhardt has authority as a responsible official (RO) as defined in [401 KAR 52:001 Section 1\(62\)](#), as we do not have a delegation request on file, and they do not appear to meet the definition by default. Mr. Megenhardt's title does seem like they could be a delegated authority, but that delegation request letter must come from someone who is an RO without delegation (president, secretary, treasurer, or vice-president of the corporation in charge of a principal business function, or other person who performs similar policy or decision-making functions for the corporation). We will need a delegation letter, or confirmation that Mr. Megenhardt performs similar policy or decision-making functions *for the corporation*, before proceeding with issuance of the draft permit.

Please let me know if you have any questions.

Colby Freeman

Environmental Engineer Technologist I
Chemical Section
Division for Air Quality
300 Sower Blvd
Frankfort, KY 40601
(502) 782 - 1467

Freeman, Colby (EEC)

From: Freeman, Colby (EEC)
Sent: Monday, April 20, 2026 5:42 PM
To: Burton JOYNER
Cc: Jesse MEGENHARDT; jeuler@decaenvironmental.com; Harley, Brian (EEC); Bittner, Zachary P (EEC); Justin SMITH; Ross, Dakota D (EEC)
Subject: Re: AI 71732 - Amrize Building Envelope, LLC - Courtesy Copy and RO Additional Information Request

Good afternoon Burton,

I wanted to go ahead and address a couple of these so we can focus on the more significant issues during the call tomorrow.

The SO₂ limit for EU IA-2 was inadvertently changed when updating the formatting for 401 KAR 59:015. I have corrected the SO₂ emission limit and the citations for it and the PM limit.

I took a look into the PM emission factor for EU 01. This factor was not changed with the renewal. It is based on a mass balance calculation submitted in a previous minor revision application (APE20180001). As specified in Section D, the 99.5% control efficiency should be applied to calculate actual emissions. Your note on the 401 KAR 59:010 limit prompted me to look at what PTE is when considering that requirement. When considering the federally-enforceable requirement to operate the controls for compliance with 401 KAR 59:010, the source-wide PTE for PM is below 60 tpy. We can remove the source-wide PM emission limit and requirements to calculate 12 month rolling totals for PM. This will address many of the insignificant activities you have requested reduced tracking requirements for. On those which have the potential to emit VOC's, we may be able to include a limit for emission units in Section B only of 88.2 tpy VOC. However, there are implications for future permitting actions that will need to be discussed.

I have written the compliance demonstration for TK-01 to be flexible for the implementation of an AMEL if approved. Specifically, the first **Compliance Demonstration Method** under 1. Operating Limitations for TK-01 (see pg. 11-12 of the courtesy copy) lists (1) general compliance requirements for Subpart Kb, (2) requirements if compliance is demonstrated through a closed vent system and control device, and (3) requirements if compliance is demonstrated with an AMEL. The second **Compliance Demonstration Method** and 1. Operating Limitations c. references the requirements necessary to demonstrate 90 percent control for compliance with the source-wide VOC emission limit. The compliance demonstration explicitly points back to the Subpart Kb requirements "after commencing installation and operation of a 40 CFR 60, Subpart Kb control system." I recognize that we can provide more clarity in the permit that 1. Operating Limitations c. and most of the corresponding monitoring, recordkeeping, and reporting requirements will be superseded by requirements in an approved AMEL (most of the operational requirements would be covered by the AMEL, but records of monthly emissions prior to the AMEL would need to be maintained still). I intend to add the VOC emission factor for TK-01 to the table in Section D with a note on when to use a 90% control efficiency (when operating in compliance with the vapor balancing requirements) and when to use a 98% control efficiency (when operating in compliance with an approved AMEL).

The requirements for EU 03 (FUG 04) are pursuant to 401 KAR 50:012, which is present in the current permit. The compliance demonstration in the current permit states that "The permittee shall operate in accordance with the Reasonable, Available, and Practical (RAP) analysis submitted to the Division on August 4, 2020." The current Statement of Basis and Summary includes the following information regarding the RAP analysis:

"To limit VOC off-gassing during storage, the facility has identified the following work practice standards to satisfy the requirement of 401 KAR 50:012, Section 1(2):

1. Stretch wrapping to protect the product while in storage; and
2. Limiting the movement of the finished board while waiting for shipment.

These are also required to maintain the VOC in the encapsulated cells of the finished product for better product quality."

I can't speak to why these requirements were not specified in the permit before, although I want to emphasize that the underlying requirement has not changed. We can discuss the possibility of an updated RAP analysis tomorrow. I look forward to speaking with you then.

Thanks,

Colby Freeman

Environmental Engineer Technologist I
Chemical Section
Division for Air Quality
300 Sower Blvd
Frankfort, KY 40601
(502) 782 - 1467

From: Burton JOYNER <burton.joyner@amrize.com>
Sent: Monday, April 20, 2026 11:04 AM
To: Freeman, Colby (EEC) <colby.freeman@ky.gov>
Cc: Jesse MEGENHARDT <jesse.megenhardt@amrize.com>; jeuler@decaenvironmental.com <jeuler@decaenvironmental.com>; Harley, Brian (EEC) <Brian.Harley@ky.gov>; Bittner, Zachary P (EEC) <Zachary.Bittner@ky.gov>; Justin SMITH <justin.smith2@amrize.com>; Ross, Dakota D (EEC) <dakota.ross@ky.gov>
Subject: Re: AI 71732 - Amrize Building Envelope, LLC - Courtesy Copy and RO Additional Information Request

This Message Originated from Outside the Organization

This Message Is From an External Sender.

Report Suspicious

Good morning Colby et al,

Here is a primer list for our discussion tomorrow.

1. Can you explain the regulatory or requirement changes that made this draft air permit significantly more stringent than those issued over the facility's last 20+ years of operation?

For example but not limited to: a) testing requirements specifically for isopentane and acetone analytes compared to blanket VOCs; b) SCAQMD method 306-91 to analyze the isopentane content of freshly cut

Freeman, Colby (EEC)

From: Burton JOYNER <burton.joyner@amrize.com>
Sent: Friday, April 24, 2026 1:58 PM
To: Freeman, Colby (EEC)
Cc: Jesse MEGENHARDT; Jim Euler; Justin SMITH; Harley, Brian (EEC); Ross, Dakota D (EEC); Bittner, Zachary P (EEC)
Subject: Technical Comments and Requested Revisions – Permit F-26-008 (Amrize Building Envelope, LLC)

This Message Originated from Outside the Organization

This Message Is From an External Sender.

[Report Suspicious](#)

Good afternoon Colby,

Thank you for your ongoing collaboration during this permitting process. Following a technical review of the draft requirements for Permit F-26-008, we respectfully submit the following comments and requests for revision. These comments align with the formal permit renewal application and technical support letter submitted on our behalf by DECA Environmental & Associates, Inc. (DECA) on October 27, 2025.

- **Section B, EU-03 (Compliance Demonstration):** Please revise the sentence to include the words “**primary saleable**” as follows: *"The **primary saleable** product shall be encapsulated in stretch wrapping to protect the product while in storage."*
- **Tank Modifications:** Regarding the new regulatory requirements for tanks, we respectfully request **60 days** to submit a proposal for physical changes and **120 days** after that for implementation.

The draft permit significantly expands the scope of performance testing from the previous permit. While the previous permit focused on Destruction Efficiency (DE) and Capture Efficiency (CE), the new draft introduces a complex mass-balance approach to determine uncontrolled VOC emission factors. We have several technical concerns regarding this shift:

- **Reliability of Established Data:** RTO-2 successfully completed initial performance testing on August 10, 2021, demonstrating compliance with both capture and destruction efficiency requirements. Since that time, there have been no physical, mechanical, or operational modifications to the RTO, enclosures, or ductwork that would affect performance, and the emission control device has been maintained in accordance with the manufacturer's specifications.
- **Incompatibility of Test Methods:** After consulting with two independent stack testing firms, we have determined that Methods 204A and 204F are not ideal for our specific laydown process. Furthermore, SCAQMD Method 306-91—designed for expandable polystyrene—would require significant, unproven modifications to accommodate polyisocyanurate foam.
- **Capture Efficiency Logic:** For the 2021 testing, the following logic was accepted. Our process line is 108 feet long. The laminator (104 feet) already meets Method 204 requirements. While the remaining 4-foot pour table is historically categorized as fugitive, it is equipped with two dedicated vents pulling air directly to the RTO, resulting in a 96.3% capture efficiency.

In accordance with the justification provided in our October 2025 technical support letter, we respectfully request that the agency reconsider the additional testing requirements for Process IDs 01 and 03. Specifically:

- We ask that the testing requirements return to the framework of the previous permit, focusing strictly on RTO DE and CE.
- If the agency maintains the requirement for a new capture efficiency demonstration, we request that the methodology remain consistent with the established protocol used in 2021 rather than the new mass-balance/Method 306-91 approach.

We believe this approach maintains the Division's authority while avoiding redundant and unnecessary testing for unchanged systems. We would like to invite your team to our facility to view the process layout firsthand; we believe a site visit will clarify why the 2021 accepted test methodology is the most technically sound approach for this line.

Respectfully,

Burton

BURTON JOYNER

Regional EHSS Manager

Anoka, Beech Grove, Florence, Plainfield

burton.joyner@amrize.com

Amrize

M: (859) 490-1564

[Amrize](#) | [LinkedIn](#) | [Facebook](#)



This email is confidential and intended only for the use of the above named addressee. If you have received this email in error, please delete it immediately and notify us by email or telephone.